



A Design Manual
For Xpress Stations and
Park & Ride Facilities

Park Ride

DECEMBER 20, 2019

VERSION 2.0

Prepared By:



THIS PAGE IS INTENTIONALLY LEFT BLANK



Xpress Station and Park & Ride Design Manual

DECEMBER 20, 2019

VERSION 2.0

Prepared for:

State Road and Tollway Authority
245 Peachtree Center Ave, NE, Suite 2200
Atlanta GA, 30303-1224
Phone: (404) 893-6100
Fax: (404) 893-6160
www.srta.ga.gov

Prepared by:



1600 RiverEdge Parkway, NW, Suite 700
Atlanta GA, 30328
Phone: (770) 933-0280
Fax: (770) 933-0970
www.atkinglobal.com/northamerica

Table of Contents

Document Revision Record	v
1. Introduction	1
2. Design Guidelines	2-7
2.1 How to use the Design Manual	
2.2 Codes and Other Approvals	
2.3 Buy America Requirement	
2.4 Safety and Security	
3. Defining Access.....	8-11
3.1 Access Hierarchy	
4. Mode of Access	12-19
4.1 General Design Consideration	
4.2 Separation Between Modes	
4.3 Pedestrians	
4.4 Walkway Surfaces and Dimensions	
4.5 Intersections, Crosswalks, and Medians	
4.6 Bicycle Access	
4.7 Transit	
4.8 Kiss & Ride	
4.9 Pick-Up/Drop-Off Zones	
4.10 Taxi Queues	
5. Park & Ride.....	20-27
5.1 General	
5.2 Park & Ride Lot Size	
5.3 Park & Ride Layout	
5.4 Parking Structures	
5.5 Parking Access	
5.6 Signage	
5.7 Charging Stations	
6. Vehicle Access and Circulation	26-28
6.1 General Access	
6.2 Vehicle Connections	
6.3 Access Roads	
6.4 Location of Access Points	
7. General Design Requirements	32-33
7.1 Temporary Facilities	
7.2 Planning for the Disabled	
7.3 Environmental Protection	
8. Site Design Requirements	34-45
8.1 Site Layout and Grading	
8.2 Streets and Drives	
8.3 Parking	
8.4 Sidewalk and Bus Plaza Criteria	
8.5 Equipment and Utilities	
8.6 Construction Requirements	

9. Architectural Requirements	46-49
9.1 General Criteria	
9.2 Setback Criteria	
9.3 Height Limits	
9.4 Exterior Building Materials	
9.5 Roof Design	
9.6 Exterior Building Equipment	
9.7 Exterior Building Lighting	
10. Landscape and Site Furnishing Requirements	50-71
10.1 Introduction	
10.2 Landscaping Design Objectives	
10.3 General Landscape Criteria	
10.4 Recommended Plant List	
10.5 Parking Lot Landscaping	
10.6 Landscape Irrigation	
10.7 Landscape Maintenance	
10.8 Site Furnishings	
11. Site Lighting and Emergency Call Box Requirements	72-105
11.1 Introduction	
11.2 General Lighting Design Criteria	
11.3 Emergency Call Box	
12. CCTV Requirements	106-111
12.1 Introduction	
12.2 CCTV Design Objectives	
12.3 General CCTV Criteria	
12.4 System Components	
13. Signage, Graphics and Approved Color Palettes	112-117
13.1 Introduction	
13.2 General Signage Criteria	
13.3 Entry Monument Sign	
13.4 Approved Color Palettes	

14. Specifications / Special Provisions 118-440

(All other specifications that are not listed below shall conform to Georgia Department of Transportation (GDOT) Standard Specifications Construction of Transportation Systems, 2013 Edition)

Architectural

(Includes Section 999 Architectural Construction - Maintenance Building and Section 763 - Bus Pavilion)

Architectural and Structural

Cast-In-Place Concrete	119-136
Concrete Unit Masonry	137-151
Structural Steel Framing	152-161
Steel Decking	162-167
Rough Carpentry	168-173
Thermal Insulation	174-175
Vapor Barrier	176-177
Formed Metal Roofing	178-181
SBS Modified Bituminous Membrane Roofing.....	182-190
Joint Sealants	191-196
Metal Doors and Frames.....	197-202
Glass and Glazing.....	203-209
Resilient Base	210-213
Painting.....	214-218
Fire Extinguishers.....	219-220

Mechanical

General HVAC Requirements	221-227
Test and Balance.....	228-230
Piping and Specialties.....	231-234
Ductless Split Heat Pump AC Systems	235-240

Utilities

Section 670 Water Distribution System	241-253
Section 999 Detention Pond - Underground Detention System....	254-256

Electrical

(Included in Section 999 - Electrical Construction - Lighting Complete)

Section 009 - Miscellaneous Construction - Emergency Call Box	257-259
Enclosed Switches and Circuit Breakers	260-269
Fuses	270-273
Grounding and Bonding for Electrical Systems.....	274-281
Hangers and Supports for Electrical Systems.....	282-287
Identification for Electrical Systems	288-298
LED Exterior Lighting.....	299-307
LED Interior Lighting	308-314
Lighting Poles and Standards.....	315-322
Low-Voltage Distribution Transformers	323-330
Low-Voltage Electrical Power Conductors and Cables.....	331-335
Panelboards	336-345
Raceways and Boxes for Electrical Systems.....	346-354
Wiring Devices.....	355-360

CCTV (By Others)

Section to be included at a later date

Signage

Section 009 - Misc. Construction - On-Site Decorative Signage ...	361-371
Section 754 Monument / Sculpture - Entry Monument Signage...	372-387

Landscape

Section 700 Grassing (Seeding and Sodding).....	388-404
Section 701 Wildflower Seeding.....	405-409
Section 702 Vine, Shrub and Tree Planting.....	410-424
Section 708 Plant Topsoil.....	425-430

Site Furnishings

Section 754 Outdoor Furniture	431-434
(Includes leaning rail, bench, blast resistant waste receptacle, and bicycle rack)	
Section 009 Misc. Construction - Advertising / Map Case Display	435-438
Section 999 Miscellaneous Construction.....	439

1

Introduction



1 1.0 Introduction

Xpress serves and operates a network of 27 commuter park and ride (park & ride) lots throughout the Atlanta metro area. Xpress plans to construct an additional 3 more park and ride facilities including Hickory Grove, Sugarloaf and Mt. Carmel. Xpress park & ride lots combine the best elements of car use and transit, as they enable potential users to drive to a park & ride facility where they can use Xpress line-haul transit service to their metro Atlanta destinations. Commuters from suburban areas, including state employees, students, and employees working in downtown Atlanta Midtown, Perimeter Center, and Buckhead are the type commuters typically encouraged to use the Xpress service and park & ride lots. Commuters who would otherwise utilize local highways to travel to and from work during the week may find these as a viable alternative for their commute to avoid current congestion levels and downtown parking fees.

The distance an individual must travel to arrive at a park & ride facility is a significant determinant of usage. Trip makers tend not to patronize park & ride lots that are too far from home relative to the length of the overall trip, and where there is competition between closely spaced facilities, driving distance from home is a key attribute in selecting which lot to use. Distance from home

is thus a crucial factor in planning location and size of park & ride facilities.

Knowing this, State Road and Tollway Authority (SRTA) strives to increase the emphasis on establishing park & ride lots to support alternative commute modes to decrease the demand on the local roadway systems and to help mitigate congestion. Table 1 provides a list of existing state-owned Park & Ride lots, their location, and the number of parking spaces at each lot. There are also nine leased lots and eight that are provided by a local county or city government. The lots sizes range from 100 to over 900 parking spaces. Each lot has user amenities that must comply with state and local building codes (for minimum structural requirements) and shall also meet American with Disabilities Act (ADA) standards for design and construction specifications including ADA Access Signs Regulations Marking and identification of accessible parking spaces.

All Xpress park & ride lots include parking spaces, handicap parking spaces, passenger loading area, bus lanes, and signage. State-owned park & ride lots also have video surveillance cameras, passenger pavilion, benches, bike racks, emergency call boxes, real-time passenger entry monument/information signs, wayfinding signage, trash receptacles, kiss-and-ride area, electric vehicle charging stations, landscaping, and lighting.

Table 1: Existing State-Owned Park & Ride Lots

Name of Lot	Location	Parking Spaces
Cumming	163 Old Atlanta Road, Cumming, GA 30040	486
Hamilton Mill	3220 Sardis Church Road, Buford GA 30519	917
Hiram	79 Metromount Road, Hiram, GA 30141	159
Jonesboro	8488 Tara Boulevard, Jonesboro, GA 30236	588
Newnan	75 Holz Parkway, Newnan, GA 30265	712
Panola Road	5290 Minola Road, Lithonia, GA 30038	630
Powder Springs	5100 Powder Springs-Dallas Road, Powder Springs, GA 30127	271
Riverdale	6842 L Hutchinson Pky Riverdale, GA	271
Stockbridge	656 Highway 138 West, Stockbridge, GA	402
Town Center - Big Shanty	3019 George Busbee Pky Kennesaw, GA 30144	646
West Douglas	7500 Douglas Blvd Douglasville, GA 30135	545

2

Design Guidelines



2.0 Design Guidelines

Designing a new park & ride facility, or an expansion for an existing one, requires consideration of several design factors including accommodations to meet ADA requirements. External design factors include entrances and exits for the facility, transit access, traffic control devices, and wayfinding/regulatory signs. Internal design factors involve much more detail including: parking layout and vehicle circulation, transit facilities and loading areas, carpool/vanpool staging areas, pavement, drainage, signs and pavement markings, landscaping, security, user amenities, community integration, lighting, fencing, and sustainable green designs, where applicable.

To assist in the designing process, SRTA has prepared station and park & ride design standards or guidelines for state-owned lots.

SRTA's ability to significantly modify or rehabilitate leased lots is typically limited by agreements with property owners and Federal Transit Administration (FTA) regulations and guidelines.

This Xpress Station and Park-and-Ride manual is organized to flow logically through the station and park & ride implementation processes from planning and design to maintenance and facility management. Chapters are arranged in the following order:

1. Introduction
2. Design Guidelines
3. Defining Access
4. Mode of Access
5. Park & Ride
6. Vehicle Access and Circulation
7. General Design Requirements
8. Site Design Requirements
9. Architectural Requirements
10. Landscape and Site Furnishing Requirements
11. Site Lighting and Emergency Call Box Requirements
12. CCTV Requirements

13. Signage, Graphics and Approved Color Palettes

14. Specifications

Appendices are found at the end of this guide and are referenced in the main body of the document.

The design guidelines consolidate and expand upon SRTA's existing design criteria for station and park & ride site and access planning, including requirements for pedestrian and vehicular access, traffic procedures, and transit operational requirements.

2.1 How to Use the Design Manual

To protect the interest of the users, it is imperative that all station and park- and- ride facility development be required to follow the same minimum standards for site, planning, architectural design, construction and maintenance.

The design guidelines should be used during the access planning and designing process of each individual site development as it relates to items such as materials, plantings, setbacks, lighting, and signage. The diagrams in this manual should be used as a guide and should not replace actual construction details. Actual construction details should be designed to meet all applicable requirements established by the local municipal code, and/or Georgia Department of Transportation (GDOT) and/ or federal standards. In some site conditions, these diagrams may not be applicable due to local standards. For such cases and other potential design conflicts, please consult SRTA. If any conflict occurs between these guidelines and city, state, federal or other requirements, ordinances, laws or regulations, the more restrictive requirement shall apply.

2.2 Codes and Other Approvals

SRTA will review submittals only for conformance with the overall objective of the development and or general compliance with the requirements in these guidelines. Approvals of submittals by SRTA does not relieve the applicant of the responsibility of obtaining all other necessary approvals and permits from appropriate agencies and authorities, and from complying with all other applicable laws, codes

and ordinances. SRTA approval of submittals shall not be construed as any assurance of the safety, appropriateness or suitability of any Improvement or the conformity of submittals with any applicable laws, codes and/or ordinances. If conflicts exist between GDOT and/or federal standards and local code or ordinances, the more stringent requirement shall apply. All reference material shall follow the latest edition. Below is a list of reference material that should be followed.

Reference Material

1. AASHTO Guide for facilities
2. GDOT Design Policy Manual
3. GDOT Construction Standards, Details, and Specifications
4. Americans with Disabilities Act of 1990 (ADA) Standards for Accessible Design
5. Accessibility Handbook for Transit Facilities, FTA
6. Americans with Disabilities Act Accessibility Guidelines (ADAAG), U.S. Department of Justice and U.S. Department of Transportation
7. Manual on Uniform Traffic Control Devices, Federal Highway Administration (FHWA)
8. A Policy on Geometric Design of Highways and Streets, American Association of State Highway and Transportation Officials (AASHTO)
9. Design and Safety of Pedestrian Facilities, Institute of Traffic Engineers (ITE)
10. Designing Sidewalks and Trails for Access, Part I of II: Review of Existing Guidelines and Practices, FHWA
11. Guide for the Planning, Design, and Operation of Pedestrian Facilities, AASHTO
12. Guide for the Development of Bicycle Facilities, AASHTO
13. Guide for the Design of Park & Ride Facilities, AASHTO
14. Georgia Stormwater Management Manual
15. IES Lighting Handbook
16. American Standard for Nursery Stock
17. Xpress Service Standards and Policies

2.3 Buy America Act (BAA) Requirement

Buy America Act requirements apply. To meet Buy American the steel, iron, and manufactured goods used in the project must be produced in the United States. Projects must include in their bid or request for proposal (RFP) specification for procurement of steel, iron or manufactured goods an appropriate notice of the Buy America provision and require, as a condition of responsiveness, that the bidder or offeror submit with the bid or offer a completed Buy America certificate.

Exceptions to the Buy American Act:

There are five primary exceptions to the Buy American Act:

- 1) the purchase of domestic products would be inconsistent with the public interest;
- 2) the cost of the domestic products is unreasonable;
- 3) domestic products are not reasonably available in the quantity or quality required;
- 4) the procurement is for use outside of the U.S.;
- 5) the procurement is below the micro-purchase threshold of \$3000. In addition, the Federal Acquisition Regulation (FAR), which implements the BAA requirement, excludes information technology that is a commercial item.

1. Inconsistent with the public interest: The Department of Defense uses the public interest exception to waive the BAA requirement for countries that have entered a Reciprocal Procurement Memorandum of Understanding (defense MOU) with the United States. These MOUs cover defense goods that are excluded from trade agreements that cover government procurement.
2. Unreasonable cost of domestic products: To determine whether a domestic price is unreasonable, a price differential (evaluation factor) is added to the price of the lowest acceptable foreign offer. A 6% differential is used for most federal contracts. But, a 12% differential is used if the lowest domestic price is from a small business. The Department of Defense uses a 50% differential for its procurement. The differential is added to the price of the lowest foreign offer and then compared to the domestic offer. If the domestic price exceeds the foreign price with the differential, then it is determined to be unreasonable.

3. **Insufficient quantity or unsatisfactory quality:** The BAA does not apply where products are not produced or manufactured in the United States in sufficient and reasonably available commercial quantities and of satisfactory quality. A non-availability determination has been made with respect to a list of products in the FAR. According to the FAR, that determination does not mean that there are no domestic products. Rather, it means that domestic sources can only meet 50% or less of total federal government and non-government demand. Federal agencies may also make individual non-availability determinations.
4. **Micro-Purchase Threshold:** The Federal Acquisition Streamlining Act of 1994 excluded micro-purchases from the application of the BAA. The current micro-purchase threshold is \$3000.
5. **Use Outside of the United States:** The Buy American Act only applies to products procured for use in the country. However, the Department of Defense applies restrictions similar to the BAA to its procurement of products and construction materials for use outside of the U.S. under its Balance of Payments Program.
6. **Information technology that is a commercial item:** The federal regulations provide an exemption from the BAA for the procurement of information technology that is a commercial item.

2.4 Title VI

Title VI of the Civil Rights Act of 1964 prohibits discrimination based on race, color, and national origin in programs and activities receiving federal funding assistance. Per circular 4702.1B issued by the Federal Transit Administration (FTA), all providers of fixed route transit services, that receive federal financial assistance, are required to approve and adopt service standards and policies pertaining to the allocation of transit services and amenities.

The Xpress Service Standards and Policies document as approved by the SRTA Board of Directors on April 18th, 2017 establishes minimum standards for transit amenities at state-owned park and ride lots, leased lots, and interagency lots owned and controlled by other transit systems or units of local government. These standards are intended to provide an equitable distribution of transit amenities across the system.

2.5 Safety and Security

The project team (SRTA/design consultant) will take a technical approach to identify and assess the proposed park & ride project's potential effects on public safety and security consist of:

1. Review of existing published safety and security provisions of SRTA and GDOT
2. Review of federal requirements, including those of the FTA and FHWA
3. Coordination with federal, state, and local agencies having jurisdiction over safety and security, as required
4. Review of the comments and concerns raised during the public scoping process
5. Field review to assess the interrelationship between the proposed park & ride facility and the adjacent communities to understand their composition, character, context, and potential impacts
6. Comparison of the existing road network along the project site to the proposed future service and facilities to assess the potential needs for increased safety and security features or procedures considering SRTA, GDOT, FTA, FHWA, TSA, and other policies, guidelines, and regulations

Security measures can be active or passive. Active security measures are incorporated in the design of Xpress stations and parking & ride facilities using specialized equipment like CCTV cameras. Passive security measures are the security measures that incorporate the concepts of Crime Prevention Through Environmental Design (CPTED). Xpress stations and park & ride facilities incorporate the following CPTED concepts when possible:

1. **Lighting** - Lighting is an important security measure in a parking & ride facility. Adequate lighting is a deterrent to criminal activity. It can contribute to the other CPTED concepts and active security measures such as CCTV cameras.
2. **Natural Surveillance** – The concept of natural surveillance is applied in the design of Xpress stations and park & ride facilities. The ability of people walking by a park & ride facility or looking out the window of an adjacent business or residential facility to view the activities going on inside the parking & ride facility enhances the security of the facility.
3. **Landscaping** - High, dense shrubs and trees can provide excellent hiding places. Vegetation surrounding parking areas should be thinned out and kept low so predators can't hide behind them. This approach is one of the tenets of CPTED.
4. **Access Control** – Access control is an important means of reducing criminal opportunity. Access control is gained through controlling the entering and exiting of pedestrians and vehicles. Proper security of the perimeter of the parking facility enhances access control of the facility.
5. **Signs and Graphics** - Signs and graphics that are properly located in a parking facility can help passengers find where they want to go and minimize their chances of becoming a victim of crime. Additionally, a sign indicating the area is under surveillance or there are security patrols of the area may be a deterrent to a criminal.
6. **Natural Territorial Reinforcement** - Natural territorial reinforcement is achieved by landscaping, signs, and fences. It is important to remember to allow for the natural surveillance of the area from the outside; keep landscaping at the proper height and have fencing that is open in its design.

THIS PAGE IS INTENTIONALLY LEFT BLANK

3

Defining Access



3.0 Defining Access

For the purpose of this manual, we define mode of access (access mode) as a way or a means of traveling to or from Xpress park & ride facilities, or to or from the station entrance. The term mode of access can also be referred to as mode share but is more frequently referred to as mode of arrival, or mode of departure. For instance, the mode of arrival for an Xpress passenger traveling to a park & ride site can be "drove & parked" or "park & ride", but when the passenger leaves their vehicle, the method of access to the station entrance becomes walking, or the "walk mode".

Planning for station and park & ride facilities relies on actual planning factors, which may include: existing use, operational requirements, existing ridership, usable land available, mode share, growth projections, the surrounding land use, and access potential. In general, the Xpress system is a regional system with several types of stations, each with distinctive characteristics. The station type may change over time due to local or regional growth or changes in the transportation system. Typical station types include:

1. Core Stations: These are urban stations located within a downtown core. These stations are accessible primarily by walking, bicycling, and bus.
2. Line Stations: Mid-line stations are typically suburban stations, which are usually accessed by park & ride, kiss & ride, bus, bicycling, and walking modes.
3. Terminus Stations: Terminus stations are located at the end of Xpress lines. Typically, terminus stations are accessed by bus, kiss &

It can be helpful in station site planning to classify these station types for determining which transit site facilities may be expected for a geographical area. However, the combination of all station facilities should always be determined by the actual planning factors on a case-by-case basis by SRTA. This issue becomes especially important when higher density development is proposed at an or existing park & ride site.

3.1 Access Hierarchy

Since all modes of access to a station and park & ride facility cannot be given equal priority, a hierarchy has been established to provide a rationale for station site planning and design. Providing access for persons with disabilities should be planned for through all modes of access and be the highest priority. No matter which mode of access is used, Xpress facilities should be designed to meet the needs of mobility and sensory-impaired passengers. Accessible design provides benefits that will often assist other passengers. The access hierarchy is presented in Table 2.

An explanation for the reasoning behind the hierarchy follows:

1. Pedestrians: For the safety of all transit customers, pedestrians should be provided the highest priority in site and access planning. For pedestrian pathways connecting to the station passenger area, it is generally recognized that providing a safe and convenient walking environment that includes clear, unfragmented, and integrated pedestrian paths to the station passenger area will encourage more customers to walk. Both modes of access bicyclist / pedestrians should be evaluated with vehicular traffic for each site to determine a safer route. Each have similar vulnerabilities that should be taken into

Table 2: Access Hierarchy

Access Hierarchy	Site Planning/Access Considerations
Pedestrian	Pedestrians, bicyclists
Transit	BRT, commuter, express, and local buses
Kiss & Ride	Taxi queue, automobile drop-off/pick-up areas, paratransit and shuttle vans, accessible parking, car sharing, motorcycle parking, and short-term parking
Park & Ride	Accessible parking, single occupant and rideshare vehicles, and electric vehicle charging stations

account in terms of conflict with vehicles at intersections, etc...

2. Transit: Since buses generate a higher share of concentrated pedestrian activity on park & ride sites, the transit mode should be given priority over all other vehicular modes of access.
3. Kiss & Ride: Because a kiss-and-ride facility requires proximity to the passenger load area entrance for optimum function, it is afforded a higher access priority than park & ride. Kiss-and-Ride areas include facilities for passenger drop-offs and pick-ups by automobile, as well as spaces for short-term parking. A curbside lane for a taxi-stand, private shuttle buses, and automobiles dropping off or picking up passengers should be located closer to the passenger loading area entrance than short-term parking.
4. Park & Ride: Park & Ride facilities are used as all-day commuter parking. Park & Ride provides a low share of transit riders per vehicle and can detract from other modes of access. Therefore, park & ride should rank below all other modes of access in station site planning. However, park & ride is still considered an important transit mode share to Xpress and the regional transportation system. Available parking at stations can divert drivers from the region's road system to transit and provides an opportunity for customers to use the Xpress system who may not be able to use other modes to access a station.

THIS PAGE IS INTENTIONALLY LEFT BLANK

4 Mode of Access



4.0 Mode of Access

This section of the manual provides guidelines for station site and access planning according to mode of access. The Guidelines include basic planning considerations specific to each access mode (pedestrians, transit, kiss & ride, and park & ride), specific criteria for the layout of facilities, and references to methods or techniques that are applicable to typical station planning requirements. More detailed methodologies are included in the following sections. The section ends with a discussion of vehicular access, traffic controls, and circulation.

4.1 General Design Considerations

The station and park & ride site plan should respect the existing topographic conditions, including existing natural vegetation, with the goal of minimizing grading and the destruction of the existing natural conditions, as well as existing structures. Proposed sites should be planned to avoid impacts to adjacent communities or minimize unavoidable impacts through buffering and landscaping. Site facilities (bus bays, station, platform, other connecting transit facilities, kiss & ride, and park & ride) should be interconnected by pedestrian paths, which should include accessible routes between the station entrance, site facilities, and to the adjacent municipal sidewalk system. All planned and designed accessible routes shall meet ADA design criteria.

The physical layout of the site should also be consistent with the access hierarchy discussed in Section 3.1. As shown in Table 3, the bus bays are located closest to the station entrance, while the park & ride facilities are located farthest from the station entrance. More detailed diagrams of sample bus bays, kiss & ride, and park & ride facilities are included later in this section with the discussion of each mode of access.

Table 3: Allowable Walking Distance to Station Area

Connecting to an Xpress bus	500 ft. maximum from furthest bus bay to station entrance
Kiss & Ride	600 ft. maximum from pick-up/drop-off lane to station entrance
Park & Ride	1,500 ft. maximum from furthest parking space to station entrance

Note: Distance shown reflect the maximum horizontal distance allowed as measured along the actual pedestrian path. Walking: 1320 ft. or 1/4 mile=5-minute walk. 2640 ft. or 1/2 mile=10-minute walk. Estimated walking time may vary and are based on average pedestrian speed pf 4 ft. per second.

4.2 Separation Between Modes

Due to the unique needs and priorities assigned to each of the access modes, separation of modes is necessary to reduce conflicts and ensure adequate access and circulation in accordance with the established hierarchy. Separation between the different modes should be provided in the following order of priority whenever possible:

1. **Pedestrians and Other Modes:** Pedestrian safety is provided the highest priority in site planning. Pedestrian pathways should be separate from vehicular traffic wherever possible. In some situations, marked bicycle lanes may be designated on or along streets. Bicyclists should also be directed to dismount from their bicycles, by posted sign, to avoid conflicts with pedestrians in areas of heavy pedestrian traffic, such as near the station entrance.
2. **Transit and Other Modes:** Transit vehicles have the highest access priority of any motorized mode of transportation. Other modes of motorized access should not compromise access for transit vehicles. Transit flow through the site should be separated from other traffic whenever possible and bus lanes should be designed to flow in one direction through the site.

3. Kiss & Ride and Park & Ride: Kiss & Ride traffic should not be routed through park & ride areas. Nor should park & ride traffic be routed through kiss & ride areas. Kiss & Ride traffic may be combined with park & ride traffic along access roads.

4.3 Pedestrians

Good pedestrian access to station area entrances is essential in station site and access planning since all Xpress passengers eventually become pedestrians when transferring between modes. Bicycle access within the station should be linked to existing and planned bicycle paths where possible. SRTA encourages bicycle access to Xpress park & ride sites by providing bicycle racks storage at many suitable stations.

The following guidelines are provided to improve pedestrian and bicycle access at Xpress park & ride facilities.

1. Minimize pedestrian conflicts with other modes. Pedestrian paths should not cross vehicular access roads and bus lanes unless unavoidable. If a pedestrian crossing is unavoidable, a clearly marked crosswalk should be provided and it should be signalized if the volume of pedestrian crossings warrants traffic controls.
2. Direct and safe approaches for pedestrians should be provided from all adjacent streets into the station area. Minimize unnecessary changes in direction. (The directness of a path can be evaluated according to a "Coefficient of Directness", which is determined by dividing the aerial or straight-line distance between any two points by the length of the available path between those same points. The preferred coefficient of directness for any pedestrian path is 1.2 or less.).
3. Pedestrian paths should be in highly visible, well-lit areas to enhance the safety of transit patrons. Avoid locating pedestrian paths behind structures or in areas with low visibility. (Pedestrians feel safer in a well-traveled environment.).

4. Accessible routes should connect between all transit facilities and public spaces. Street furniture, lighting fixtures, signposts, newspaper stands, trash receptacles, and other elements, including hand rails along the edge of the pathway, must be located outside of the accessible route. Avoid locating grates along accessible routes, which may cause problems for the visually impaired using canes or people using mobility aids.
5. Pathways should be carefully planned to concentrate pedestrian egress. For example, bringing multiple pedestrian paths into a single exit from a station area rather than allowing them to disperse through numerous exits improves the ability for pedestrians to see and be seen by others, thus improving pedestrian safety. However, concentrating access should be balanced with the need to accommodate direct pedestrian routes.
6. Avoid designing pathways with severe changes in elevations that create particularly difficult conditions for persons with disabilities. Curbs, steps, and stairways create obstacles for persons in wheelchairs, as well as persons with strollers or wheeled luggage. Curb ramps allow access for wheeled devices up onto and down from areas raised and separated by curbs.
7. Vertical clearance of at least 8 feet should be provided along all accessible routes. Vertical clearance is necessary to accommodate taller persons and cyclists and to allow an area free of obstructions that might be hazardous to people with visual impairments.
8. Provide resting areas for people with lower stamina or health impairments along longer distance paths. Resting areas may include benches, seating walls, resting posts, and railings.
9. When possible, design for right-hand pedestrian flows to avoid cross flows, as pedestrians tend to keep to the right.

4.4 Walkway Surfaces and Dimensions

1. The surface of a walkway should be firm and stable enough to support the higher point loads of wheelchair wheels, crutch tips and other mobility aids. Monolithic, paved surfaces, such as asphalt or concrete, are preferred in areas of high-volume traffic. Unit pavers may be used if they can provide a stable and level surface. Do not use beveled pavers. Architectural style and appearance should always be balanced with the importance of accessibility and the need for a smooth, stable and slip-resistant surface.
2. If stairways are provided, make sure that they are wide enough to allow faster pedestrians room to pass. Provide a bike channel, running at the same angle as the steps, for customers to walk a bike along the stairway where appropriate.
3. If a stairway is located along the path of egress from a station entrance, stairs should meet emergency station egress requirements.

4.5 Intersections, Crosswalks, and Medians

1. Pedestrians should have the right-of-way over all vehicles in the park & ride areas and crosswalks should be located at all vehicular crossings and accentuated with textured pavement, color, or striped markings. Avoid using raised pavement at crosswalks on access roads used by transit vehicles, which may inhibit operations.
2. All crosswalks shall include appropriate levels of lighting.
3. Pedestrian activated crosswalk lighting is recommended for high traffic areas, such as signalized intersections immediately adjacent to the station.
4. The highest degree of safety must be applied along accessible routes, as many persons with disabilities, such as persons in wheelchairs, are less visible to drivers than other pedestrians.
5. Two curb ramps per corner should be provided at intersections, one in the direction of each crosswalk. Providing only one curb ramp at the apex may unintentionally direct visually impaired pedestrians or

persons using wheelchairs into the center of the intersection, rather than toward the crosswalk. Appropriate tactile paving surfaces and audible signals should be installed at all controlled and uncontrolled roadway crossings along accessible routes.

6. Curb cuts at street crossings for multi-use pathways should be the full width of the pathway.

4.6 Bicycle Access

1. Provide connections to bicycle paths or facilities within the station area to expand the catchment area for bicycles. Connections should consider the needs of different bicycle user types.
2. Include information about bicycle routes in the area on posted signs and with wayfinding information.
3. Provide direction to bicycle parking.
4. Bicycle access should not interfere with pedestrian movements. Bicyclists should be directed to dismount and walk bicycles in areas of concentrated pedestrian traffic, such as near station entrances.
5. Avoid designing bicycle routes that require traversing stairs.
6. Bicycle paths should be designed according to AASHTO's Guide to the Development of Bicycle Facilities and local standards.
7. A minimum of one bicycle rack should be provided at all stations, preferably two racks; with additional bike racks to be considered based on demand. Site design should consider locating bike racks in shaded / covered space with the vending machines. ADA access to the vending machine shall be the ultimate determining factor in placing any bike rack nearby a vending machine.
8. The number of bicycle racks or lockers should be determined based on existing demand and recommendations from the local jurisdictional bicycle coordinator for projected demand. (Demand is affected by surrounding land use, terrain, and availability of bicycle paths or routes. Denser land uses will have a greater potential to generate bicycle usage, as will specific land use types, such as college campuses, activity centers, residential neighborhoods, and public buildings. Additionally, if vehicular parking

is constrained or unavailable, some persons may use bicycles as a second option.)

9. Bicycle racks should not be located to impede pedestrian movements.
10. Bicycle parking areas should be designed so that bicyclists can ride all the way to the

4.7 Transit

Transit access may be provided by SRTA, local jurisdictions' bus operations, and regional and intercity bus services. Transit provides access to Xpress for persons who are transit dependent, eases access for persons with disabilities, and moves a large number of passengers efficiently.

The following guidelines are provided to improve transit access at Xpress park & ride stations:

General Access Considerations

1. Transit loading/unloading facilities should be located closer to the station entrance than any other vehicle mode. Transit passengers should not have to cross any vehicle lanes to access the station entrance. If pedestrian crossings of bus lanes are unavoidable, they should be well marked, lighted, and clearly identifiable for bus drivers. Provide clear pedestrian paths and a visual connection between transit loading/unloading areas and the station entrance.
2. Consolidate transit facilities to one area of the station site to facilitate bus-to-bus transfers.

3. Bus traffic should be separate from automobile traffic wherever possible and should be designed to flow in one direction through the station site. Other modes of motorized access should not negatively impact the operations of transit vehicles.
4. Transit priority improvements, such as signal priority or exclusive lanes, that provide faster, and more reliable service should be encouraged and applied when appropriate. A signal warrant and state agency would need to approve prior to implementation.
5. With few exceptions, park & ride facilities should be designed to accommodate transit vehicle access and capacity demand during the AM peak hour period. The AM peak hour period is used for planning transit facilities when transit headways are more frequent and passenger boarding's are highest.
6. Park & Ride facilities with sawtooth bays are preferred when multiple bus bays are required and there are a considerable number of terminating routes and bus-to-bus transfers. Bus bays should be designed in conformance with SRTA standards and guidelines (Figure 4.71).
7. A one-way counter-clockwise loop is the preferred layout for park & ride facilities, so that buses can recirculate within the bus terminal. Two-way circulation should be

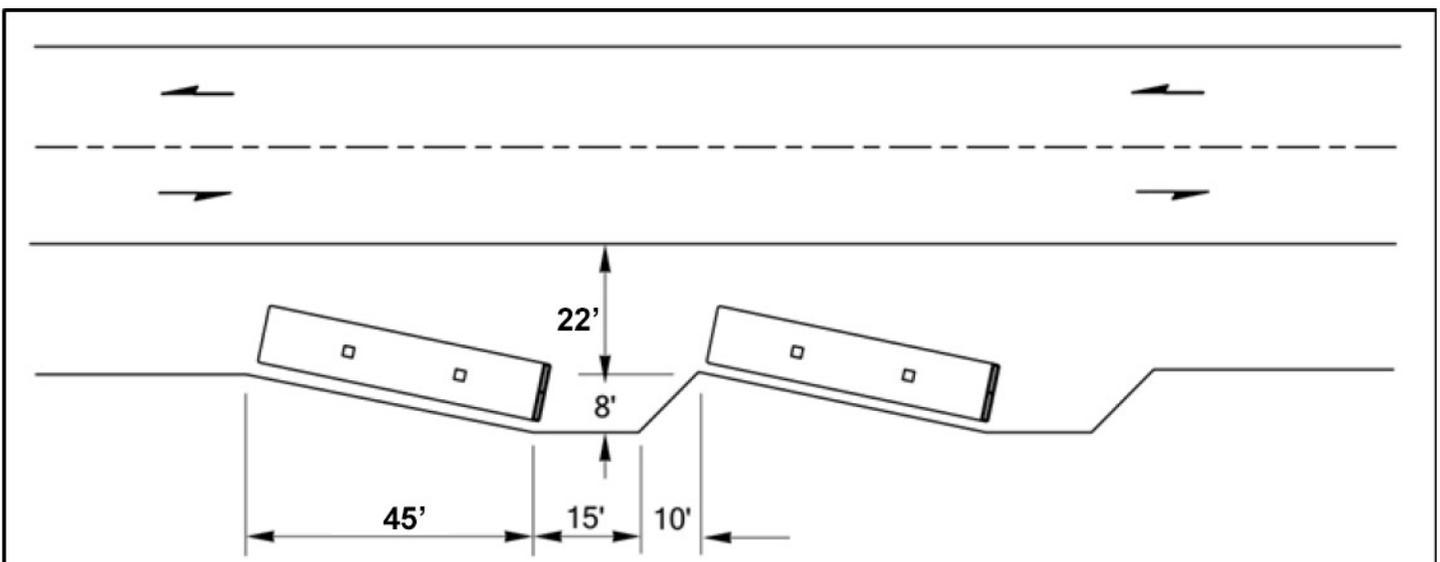

Figure 4.71 - Sawtooth Bus Design (Note: Dimensions shown are for a 45-ft bus, adjust the length when designing for a longer bus).

avoided unless required due to unusual site constraints. Lanes for bus storage should be in proximity and within view of the bus bays to allow layover buses to move to their assigned bay when it becomes vacant or at the scheduled time for boarding. (Figure 4.72)

4

8. Bus bays should be designed for passenger boarding's and alighting's on the right side of the bus where doors are located.
9. Pedestrian crossings of the bus lanes should be avoided. However, pedestrian access to all destinations near bus loops shall be provided (circling the loop, crossings at bus entrance, etc... Pedestrian barriers (fencing/ landscaping) may be provided to discourage or prevent crossings at undesignated areas. Barriers should not impede visibility. If pedestrian crossings of bus lanes are unavoidable, then crosswalks should be located at the end of bus arrays, rather than in the middle, where they are less likely to conflict with bus operations. Crosswalks should be clearly marked, well lit, and highly visible from the roadway.
10. The number of bus bays needed will be determined by SRTA. (Generally, provide one berth for six buses per hour with no more than two to three connecting services per boarding berth. The capacity of a berth is generally dependent upon the bus's dwell time and clearance time.)

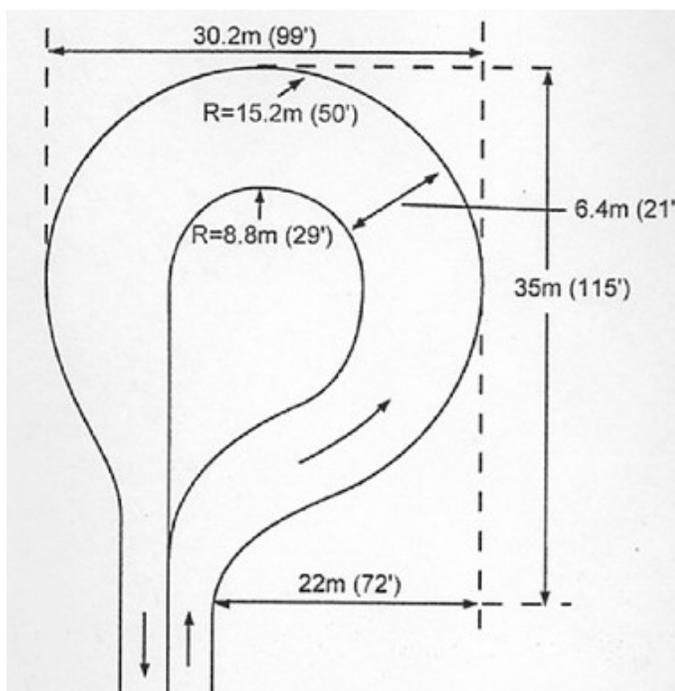

Figure 4.72 - Sample Bus Loop Design

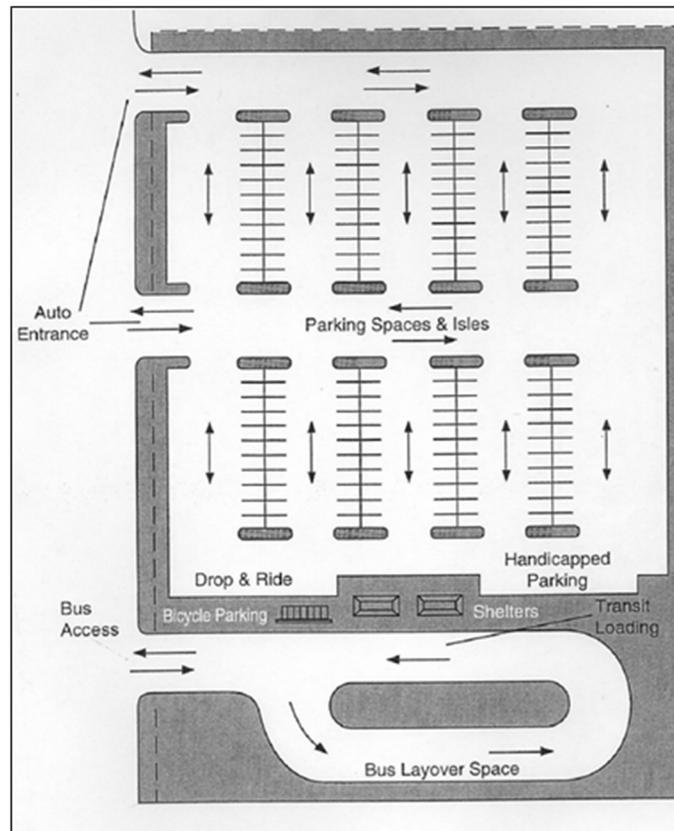

Figure 4.73 - Sample Bus Bay Design

4.8 Kiss & Ride

The kiss & ride lot is primarily used for dropping-off and picking-up Xpress passengers. Kiss & Ride facilities typically include taxi stands, motorcycle parking, provisions for paratransit vehicles and private shuttle buses, short-term parking, and parking for car sharing vehicles. The kiss & ride facility should be designed to maximize vehicle turnover, facilitate traffic flow and to avoid traffic conflicts. Each facility shall be evaluated during the design process to determine the kiss and ride configuration requirements per expected vehicles (sizes and types).

General

1. All Xpress midline and terminus stations that have park & ride facilities should also have separate kiss & ride line stations: Mid-line stations are typically suburban stations, which are usually accessed by park & ride, kiss & ride, bus, bicycling, and walking modes.
2. For optimum function, the kiss & ride facility should have a direct visual connection with the station entrance, where a driver waiting in an automobile can quickly locate their passenger exiting the station.

Kiss & Ride facilities must be convenient for both pedestrians and automobiles to encourage use. Kiss & Ride facilities that are not convenient to use, too congested, too remote from the station entrance, or have poor visibility, will encourage motorists and taxis to find another location in the station site or adjacent streets for pick-up/drop-off activity that may cause undesirable conflicts with other traffic.

3. The walking distance from the farthest parking space in the kiss & ride area to the station entrance should not exceed 600 feet, measured along the actual walking path.
4. Kiss & Ride access roads should typically be designed for one-way traffic flow and allow for re-circulation.
5. Kiss & Ride facilities should be designed to meet capacity requirements for the PM peak hour period when demand is greatest and vehicle dwell times are longest. Capacity for kiss & ride facilities can also be determined by the following method. Waiting capacity should be provided for twice the PM peak hour average per-bus arrival rate for pickups, i.e. provide a total of $(2NW/60)$ waiting spaces, where N is the number of kiss & ride arrivals in the PM peak hour and W is the average waiting time in minutes. The recommended average waiting time (W) for calculation purposes is approximately twice the average peak Xpress headway at the individual station.
6. ADA-accessible parking should be provided in all kiss & ride facilities, with these spaces located closest to the station entrance via an accessible path. Walkways should be carefully planned so that persons using the accessible parking do not have to walk or wheel behind parked cars to reach entrances, ramps, walkways, or elevators.
7. The amount of ADA-accessible parking must meet the minimum ADA requirements and any local ordinances. Local conditions and experience at sites should help determine the demand for accessible parking. If local conditions demonstrate needs greater than the ADA requirements specify, then the number of accessible spaces provided should be increased.

4.9 Pick-Up/Drop-Off Zones

1. Curbside pick-up/drop-off zones should be located on the right side of the road to discharge passengers at the curb, away from through traffic, and designed to proceed in an orderly manner.
2. Pick-up/drop-off zones should be accessible for persons with disabilities. Provide a continuous depressed curb along the sidewalk area adjacent to the taxi queue and the shuttle bus lane. Paratransit vehicles should be able to use the pick-up/drop-off zone. Pick-up/drop-off zones shouldn't conflict with any bike lanes/facilities if present (they present a major hazard, forcing bikers to weave in and out of stopped traffic and opening doors etc). Ideally place bike facilities on opposite side of road from these.
3. Roads should be single lane with a minimum width of 24 feet along curbside pick-up/drop-off zones to allow space for maneuvering around stopped vehicles.
4. To better manage traffic flow at areas of potential traffic conflict, usually at the point nearest the station entrance, direct pedestrians to designated waiting areas away from restricted curb lanes using pedestrian guards such as bollards and chains. Continuous walkway canopies may also be used to direct pedestrians to waiting areas. To encourage use, waiting areas should have benches, trash receptacles, and shelters.

Locations within Parking Structures

1. Kiss & Ride facilities may be located within a parking structure only when approved by SRTA.
2. Kiss & Ride facilities should only be located on levels of the structure with direct pedestrian access to the station entrance and must have direct vehicular access to an adjacent street.
3. Kiss & Ride facilities located within parking structures should be clearly visible from the street and other areas of the site to enhance patron safety and have good ventilation.
4. Kiss & Ride signage shall be clearly marked and visible for parking structures. Larger signage is recommended.
5. Kiss & Ride facilities located in parking structures must provide separate access and egress from park & ride vehicles.
6. Kiss & Ride facilities where private shuttle buses travel under structure should have a 12-foot minimum vertical clearance.

4.10 Taxi Queues

A taxi queue lane should be provided along a depressed curb near the station entrance, separate from private vehicle drop-offs, with the first space located at a natural point of concentration of pedestrian traffic exiting the station entrance.

5

Park & Ride



5.0 Park & Ride

Park & Ride provides vehicle access to Xpress for persons located beyond reasonable walking distance from the station or unable to utilize other access modes. Park & Ride facilities include all-day parking for single-occupant and rideshare vehicles. The following guidelines and criteria are provided to ensure adequate access is provided to park & ride facilities at Xpress stations.

5

5.1 General

1. Provide an efficient, clearly defined, and safe circulation system, with an emphasis on minimizing pedestrian/vehicular conflicts. Driving aisles should be aligned in the direction to the station entrance so pedestrians do not have to walk between parked cars. In the absence of sidewalks, pedestrians should be required to walk in the driving aisles.
2. Park & Ride facilities should be located within easy walking distance to the station entrance, which is typically less than 1,000 feet. The generally accepted walking distance from the station entrance to the farthest parking space in a park & ride facility is 1,500 feet measured along the actual

pedestrian route of travel, excluding travel distance where elevator service is available unless otherwise approved by SRTA.

3. ADA-accessible parking in the park & ride areas should be located closest to the station entrance via an accessible path. Walkways should be carefully planned so that persons using the accessible parking do not have to walk or wheel behind parked cars to reach entrances, ramps, walkways, or elevators.

5.2 Park & Ride Lot Size

1. The amount of parking should be based on demand, available land, and the capacity of the surrounding street system.
2. The minimum number of accessible parking spaces required depends on the total number of parking spaces in the lot, as seen in the table below. Furthermore, one of every six accessible parking spaces, or fraction of six, must be “van-accessible.” For example: A parking lot with 400 total spaces needs eight accessible spaces, and two of those eight spaces must be van-accessible. For new construction, it is advisable to adjust for a slightly higher estimate of accessible parking spaces, because it will be much more difficult to provide an accessible environment later if demand exceeds the supply provided. Refer to table 4 for ADA parking space requirements.

Table 4: ADA Parking Space Requirements

Total Number of Parking Spaces in Parking Facility (Lot or Garage)	Minimum Total Number of Accessible Parking Spaces Required	Minimum Number of Van Accessible Parking Spaces
1 - 25	1	1
26 - 50	2	1
51 - 75	3	1
76 - 100	4	1
101 - 150	5	1
151 - 200	6	1
201 - 300	7	2
301 - 400	8	2
401 - 500	9	2
501 - 1000	2% of total	
1001 and over	20, plus 1 for each 100, or fraction thereof, over 1000	

3. Large parking areas should be subdivided into sections to reduce the scale. Parking lots containing 500 or more parking spaces should be divided into parking areas of not more than 500 cars each. Provide major landscape buffers of 50 feet minimum width between separate parking areas (with allowance for circulation between areas).

5.3 Park & Ride Layout

1. All planned and designed accessible routes shall meet ADA design criteria.
2. Parking aisles should be oriented perpendicular towards the station boarding facility curb. Elevated (curb height) sidewalks should be provided in between facing cars, parking rows in order to separate pedestrian traffic from vehicular traffic. Cut throughs shall be provided at least every 400 feet of the aisle length. Parking may be designated adjacent to the cross aisles, except where provision of parking will interfere with pedestrian flow between the station entrance and the park & ride facility.
3. Internal parking lot circulation should encourage use of the entire lot, with a minimum of dead-end parking areas.
4. Ninety-degree parking is the standard with parking aisles designed for two-way traffic. If angled parking is required, aisles should be one-way.
5. Design speed within park & ride lots should be 5 mph. Tight turning radii, textured pavement, or other treatments should be used to restrict speed.
6. Adequate storage distance for automobile queuing should be provided at every entrance and exit. This area may be provided in the form of a circulation road and/or area extending in any direction.

5.4 Parking Structures

1. The design and construction of parking structures must conform to SRTA design Criteria and local jurisdictional codes.

5.5 Parking Access

1. Whenever possible, parking lot access points should be located upstream of heavier inbound traffic congestion.
2. Contra-flow lanes at exit/entry points should be used to increase throughput capacity for each of the peak periods. Because each parking facility is unique with different conditions for access, the number of access control points should be decided on a case-by-case basis per SRTA.

5.6 Signage

1. Regulatory signs should be provided to control traffic flow, particularly at pedestrian/bicycle/vehicle conflict points and at parking entrances.
2. Some crosswalks may warrant "State Law: Stop for Pedestrians within Crosswalk Signage."

5.7 Charging Stations

Charging stations are the point of connection to the electrical grid for electric vehicles (EVs), and the point of power for EV drivers. Recharging EVs is accomplished through connections to electric vehicle charging equipment, also referred to as Electric Vehicle Supply Equipment (EVSE). This is a protective system which communicates with the vehicle and monitors electrical activity to ensure safe charging. While the actual “charger” is contained in the vehicle, the appliance commonly referred to as a charging station or EVSE is the conduit, control, and monitoring device which connect the vehicle to the electric grid. Figure 5.71 is a diagram of the overall charging energy flow from the power grid, through the EVSE (shaded in orange) and into the vehicle through the industry standard J1772 port connector. With alternating current (AC) EVSE, charger electronics within the vehicle invert the AC power supplied by the EVSE into direct current (DC) for storage in the battery. Fast charging DC EVSE delivers high voltage (typically over 400 V) direct current straight to an electric vehicle's battery system.

Charging Levels

There are three levels commonly used to describe the charging power of EVSE: Level 1, Level 2 and DC Fast Charging

1. Level 1, 120 Volt Charging - This simplest form of charging uses a 120V AC connection to a standard residential/commercial electrical outlet capable of supplying 15-20 amps of current, for a power draw usually around 1.4 kW when charging. Charging is slow - around 3 or 5 miles of range added per hour of charging.

2. Level 2, 208/240 Volt Charging - Level 2 charging requires a 208/240V AC power connection and significantly reduces charging time. The J1772 standard connector used by most EVs can theoretically provide up to 80 amps of current (19.2 kW), although most vehicles presently available only use up to 30 amps for 3.3 to 6.6 kW charging. Charge time is significantly faster than Level 1. EVs will get between 10 and 20 miles of range per hour of charge. Level 2 charging type is the preferred basis of design for all park and rides.
3. DC Fast Charging - Sometimes referred to as Level 3, DC fast charging equipment delivers high power directly into an EV's battery system, enabling rapid charging. Typically, an 80% charge can be provided in 30 minutes or less for many all electric vehicles. DC fast charging does not use the same J1772 plug connectors as Level 2. There are three distinct connectors for fast charging equipment by various manufacturers: CHAdeMO used by Nissan, Mitsubishi and Kia; SAE Combo used by American and European makes, such as Chevrolet, BMW and Mercedes Benz; and Tesla's Supercharger used exclusively on Tesla Model S and later vehicles. Tesla has also announced an adapter allowing their owners to use CHAdeMO equipment.

It is also important to devise a policy of use for the charging station. This should cover issues relating to how the charger is utilized by patrons. It should cover topics such as if reservations are required for the spot, how a reservation can be made, how long an EV is allowed to charge, what happens if the allotted time is exceeded, etc. Currently the charging stations are intended as first come first serve spaces, (similar to ADA spaces) since there is not a feasible way to regulate usage.

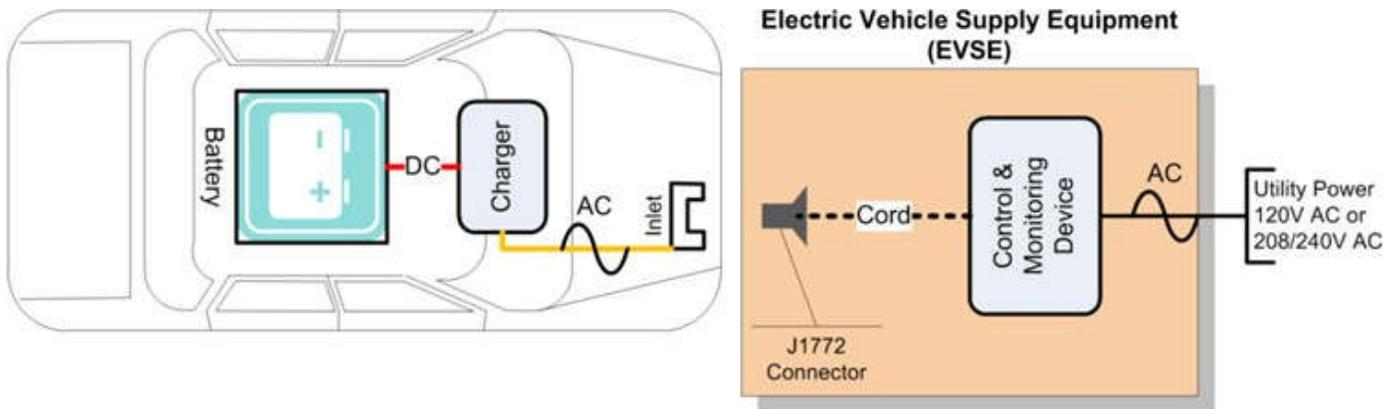

Figure 5.71 - Electric vehicle AC charging equipment diagram

General Siting Issues

1. Availability of power – Proximity to electric power service is often the key factor in determining installation cost. Placing charging equipment near existing power service will reduce cost and installation time, particularly if there is reserve capacity available to reduce any upgrade costs.
2. Constructability – As stated above, placing equipment near power sources will reduce the extent of trenching needed for conduit runs.
3. Mounting – Wall mount units generally have lower capital and installation costs, so this option is often preferred if the site has a suitable wall area. Dual mount options for charging equipment may also help reduce overall installation costs as the incremental cost of adding another port is frequently much lower than installation an additional single port unit.
4. Environmental protection – Charging equipment exposure to the elements should be minimized as much as possible. Areas prone to flooding or standing water should be avoided as much as possible.
5. Factors particularly relevant to Xpress park & ride lots include wayfinding signage to direct users to the charging equipment, parking restrictions to increase the availability of charging installations, and fee collection mechanisms to recover costs (as an option). There are a variety of models exist for generating revenue through billing users of EVSE. Of the models in practice currently, the most common are a membership-based model and a pay per use model. Many states do not allow unregulated utilities to sell electricity by the kWh, so unless there are changes to state statute, billing would be done based on time spent at an EVSE or through unlimited access for a fixed monthly fee.

Equipment Specifications

The following specifications are recommended for EV charging equipment purchases. Nearly all vendors currently selling charging equipment in the United States meets the general recommendations for all charging equipment.

1. Compliance with Society of Automotive Engineers J-1772 and/or CHAdeMO standard for EV charging plug connector dimensions and operational requirements
2. Nationally Recognized Testing Lab (e.g. Underwriters Laboratories) listed for outdoor use
3. NEMA Type 3R or 4 certifications for outdoor electrical enclosures
4. Ability to operate in extreme temperature conditions (-20 to +100 degrees F)
5. ADA accessible buttons and components
6. Warranty - Minimum 5 Year, longer desired
7. Charging amperage from 30 to 80 amps to support vehicles with higher charging power capabilities (7.2 – 19.2 kW)
8. Modular Field serviceable parts, particularly for cord and J1772 connector
9. Recommend cord length not to exceed 25 feet
10. Cord management system to keep cord off the ground and comply with National Electric Code (NEC) article 625 as it applies to cord management systems
11. Network monitoring capability for status and fault reporting.
12. Reporting on power consumption and usage patterns
13. Fee collection system using credit cards, access codes, phone operation and/or contactless RFID cards from widespread charging network(s) with customer service assistance available 24 hours a day, 7 days a week by phone (an option).

EVSE Typical Site Plans

There are many possible arrangements and designs for EVSE installations, depending on the parking area layout, availability of power, and other site considerations. General EVSE site plan considerations include:

1. Power availability (240V for Level 2, 3 phase for DC fast charging)
2. Level parking surface, preferably paved so EVSE spaces can be marked
3. Lit, visible area to address security concerns
4. Accessibility for disabled users
5. Barriers or mounting options to protect EVSE equipment from vehicles
6. Signs and pavement markings to designate sites and restrict their use



Figure 5.72 - Example of electric vehicle charging station

Perpendicular Parking Spaces

The majority of the Express' park & ride lots with public EV charging stations will be located in passenger parking lots with perpendicular parking. Figure 5.73 is an example of a wall mounted installation, which is typically the most cost-effective means of providing charging equipment if the parking area configuration allows for this. Installation costs are reduced by eliminating pedestal mounts and by allowing shorter conduit runs along building walls. The parking configuration shows typical parking stall dimensions of 9 feet wide by 18 feet long. A five-foot-wide aisle between accessible spaces provides room for disabled users to maneuver. As shown by the cord reach area, this configuration can serve several parking spaces by allowing drivers to park in the appropriate spaces or back in as necessary to provide access to the vehicle charging port.

Figure 5.74 shows an example layout of EV charging centrally located between parking aisles with the same typical parking stall dimensions of 9 feet wide by 18 feet long. This configuration can serve several parking spaces depending on the length of the charging cord. Charging port locations for several vehicles are shown on the diagram.

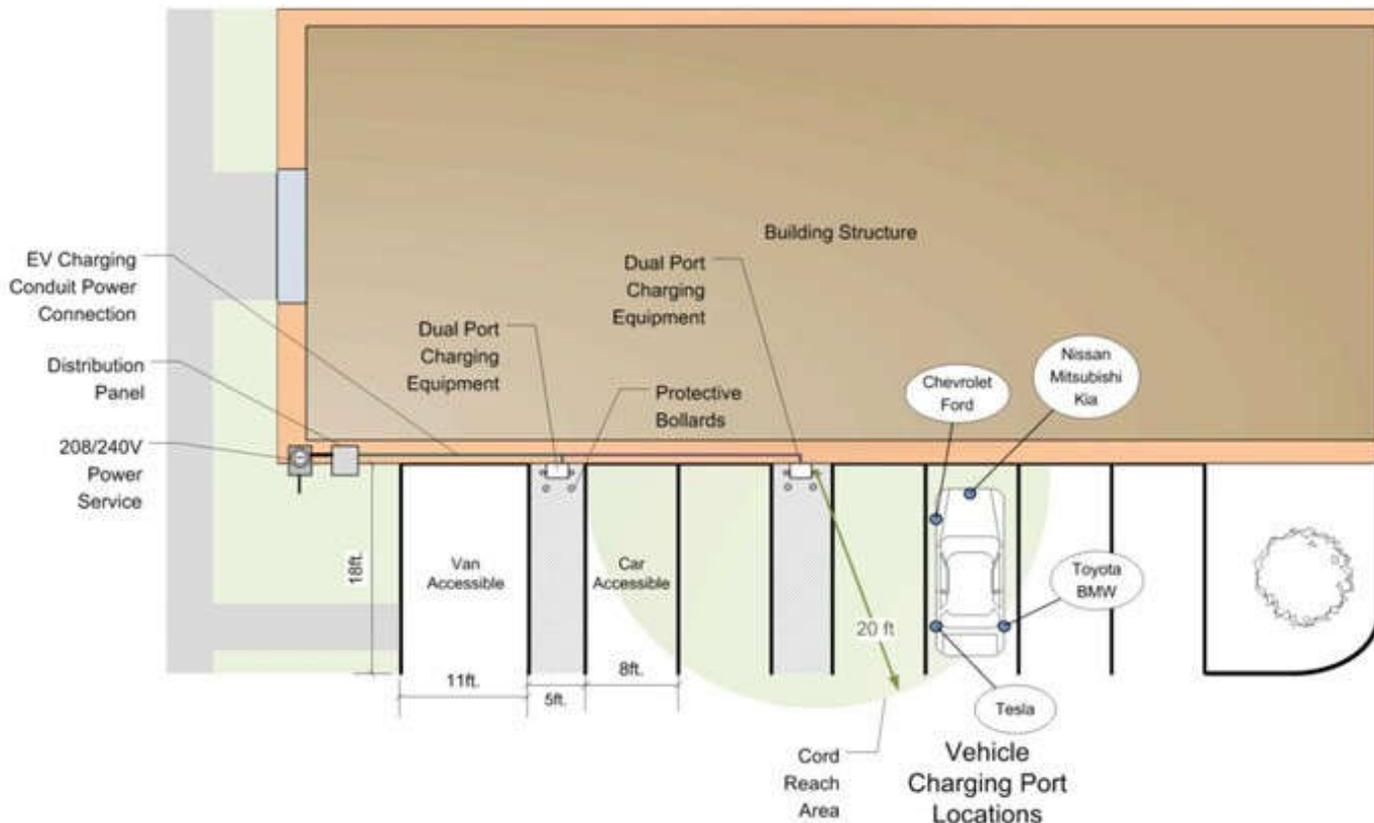

Figure 5.73 - Wall mounted EVSE example site plan diagram

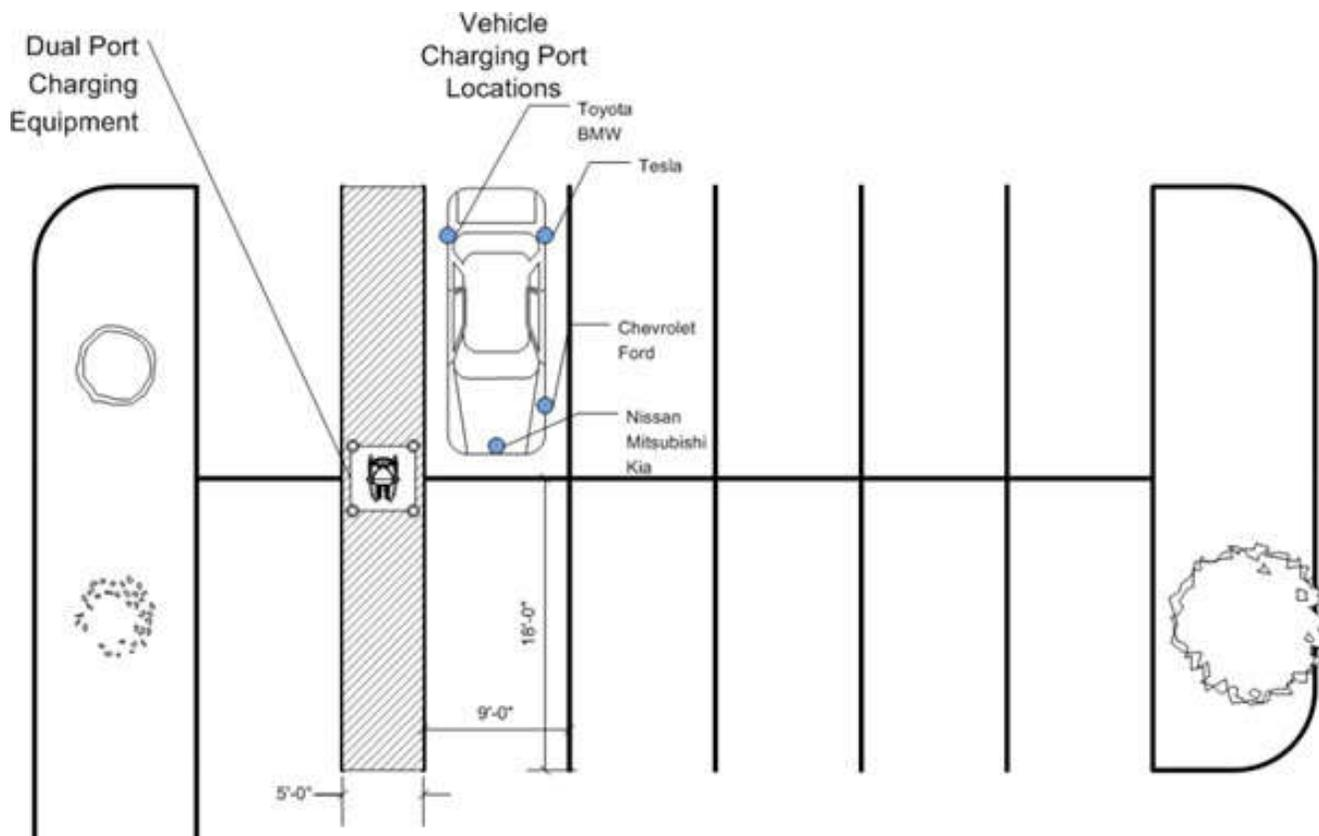

Figure 5.74 - Perpendicular parking lot site plan example

ADA Requirements

The ADA requires public parking areas to be accessible to users in wheelchairs or with other mobility limitations. The US Access Board establishes accessibility standards for public facilities, such as parking areas and fueling stations, but has not yet acted on specific ADA requirements for EV charging stations. In the absence of specific rules, the general accessibility requirements are expected to apply to EV charging installations.

5 When designing ADA-compliant PEV charging stations, consider accessibility, ease of use, and safety for disabled drivers, including those using wheelchairs or other assistive equipment. Key considerations include ensuring adequate space for exiting and entering the vehicle, unobstructed access to the EVSE, free movement around the EVSE and connection point on the vehicle, as well as clear paths and proximity to any building entrances.

Pedestrian Traffic

EV charging stations and cord sets should not interfere with pedestrian routes. Charging stations should not be placed in a location that would cause a cord to pose a tripping hazard. Pedestrian paths should be considered when designing where to install an EV charging station. Charging station site choices should consider building entry ways, pathways, street crossings and meeting points so as not to impede pedestrians.

General Service Signs

The Manual on Uniform Traffic Control Devices (MUTCD) has adopted a standard sign symbol for EV charging stations, shown in Figure 5.75. If signs are desired for locations that only provide Level 1 charging, then a supplemental plaque denoting “Level 1” could be added beneath so drivers are aware of the limitations.

The final type of signage that is required is a regulatory sign to restrict use of the parking spaces to charging EVs only. The recommended practice in Vermont is to use language restricting parking “Except for Electric Vehicle Charging” to prevent instances of EV owners taking up charging spaces without plugging into the equipment.



Figure 5.75 - MUTCD Approved EVSE Symbol

6

Vehicle Access & Circulation



6.0 Vehicle Access and Circulation

The successful functioning of the station site facilities depends on good access for vehicles to the existing roadway network. Traffic impact studies should be prepared for all major changes and developments that may affect access routes within the station area. For any traffic study, levels of service (LOS) at signalized intersections should be analyzed in accordance with procedures specified in the most current version of the Highway Capacity Manual (HCM), the industry accepted standard for roadway and intersection capacity analysis. The designer should utilize traffic simulation software when planning station site facilities, such as bus bays, Kiss & Ride lots, internal access roads, and intersections.

Any changes to the surrounding street network should consider the potential impact on transit access. Some traffic calming measures, such as street narrowing, road closures, or chicanes, may be beneficial in some cases and improve pedestrian access to Xpress stations, but they could also impede access for transit vehicles if they are located along transit routes. The following guidelines are provided to improve vehicle access and circulation between SRTA facilities and adjacent areas.

6.1 General

1. Access roads should be kept to a minimum, providing the clearest, most direct access to a site facility. Where access roads have a combined use, with bus and automobile traffic mixed, entrance and exit conditions from each facility should be carefully studied to minimize turning movement conflicts.
2. Transit improvements should seek to increase neighborhood livability. Examples include building bus stops that are pleasant pedestrian spaces and introducing turn restrictions that reduce transit delays and reduce neighborhood cut-through traffic.
3. In addition to transit vehicle access; access for station facility, maintenance, police, and emergency vehicles should also be considered.

4. Clearance over a roadway should conform to or exceed the minimum vertical clearance requirements as stated in the GDOT Design Policy Manual.
5. Existing road networks, traffic patterns, traffic signals, and all proposed road improvements by others should be identified and evaluated at the outset of design.

6.2 Vehicle Connections

1. Automobile access to Xpress stations and park & ride lots should be provided from collector streets or access roads that intersect with arterial roadways. These roads should be designed in accordance with AASHTO design standards and local jurisdictional requirements. When it is necessary to provide direct access to an arterial route, the access point should be spaced properly to avoid long queues from nearby intersections or interchanges. Avoid increasing congestion on adjacent arterial roadways or freeways, whenever possible.
2. Vehicular access to the station site that requires or increases travel through primarily residential or neighborhood streets should be prohibited unless it is within a high populated dense urban neighborhood grid that can handle the additional vehicular traffic.
3. Connections should be designed to prevent encroachment of bus turning movements into opposing traffic lanes. Traffic volumes, existing signalization, available rights-of-way, street widths, and other design elements should be evaluated when considering channelization to eliminate encroachments of bus turning movements into traffic lanes moving in the same direction.

6.3 Access Roads

1. All SRTA road designs should follow AASHTO guidelines.
2. Access roads are not to be designed to accommodate through traffic. SRTA policy is to provide access roads for traffic connecting to the local highway road system. In general, access roads should not tie into low volume residential streets, but should instead join collector or arterial street systems, in order to keep Xpress traffic out of the surrounding neighborhood unless otherwise approved by SRTA.

3. Roadway lane width is based upon anticipated traffic volume. The number of lanes assigned to ingress, egress and turns should be determined by a traffic analysis conducted by SRTA and/or others.
4. Coordinate all proposed access road intersections and entrances to Xpress facilities with State and local authorities when providing dedicated routes from adjacent major roads. At intersections, good sight lines, unrestricted by grade change, blind curves, or vegetation, and adequate queuing distance for vehicles turning from one roadway to another, are required.

6.4 Location of Access Points

1. Minimize the number of access points. Access points should be spaced at least 150 feet apart. A distance of 350 feet is considered desirable. A sufficient number of entrances should be provided so that traffic operates at LOS D or better at adjacent intersections.
2. When possible, locate access points on the right side of the roadway for inbound traffic to eliminate crossing movements. Maximizing accessibility for inbound trips may be more effective in attracting users than improvements aimed at exiting traffic.
3. Unsignalized intersections should be located so that signal control could be installed at a later time if necessary.
4. An exclusive right-turn lane should be provided only when the lack of an exclusive lane would result in unacceptable traffic operations. An additional turn lane may lengthen pedestrian crossings. If used, the lane should be a tapered section with sufficient width to accommodate the required traffic, which may include buses.
5. Left-turn storage pockets are recommended, when they can be shown to noticeably improve traffic conditions and reduce conflicts with through traffic flows.
6. Avoid locating exits directly across from highway offramps to discourage wrong-way entry onto freeways.
7. New street profiles should be "benched" at intersections and mid-block crossings to maintain a crosswalk cross slope (or profile grade on the street) of 2 percent or less. In addition, crown slopes on streets should be

kept as low as possible, but no more than 2 percent, to provide access for persons with disabilities. Wheelchair users should not be forced to travel uphill at steeper grades across the street.

8. Whenever an entrance must be located near a "T" intersection, it should be placed directly at the intersection. Offset intersections should be avoided. If an offset distance is unavoidable and provision for left turn movement is not required, the distance between the street centerlines should be a minimum of 150 feet.
9. Entrances to bus facilities must provide adequate lane widths and stacking distances to allow simultaneous entering and exiting of buses to easily negotiate the areas.

THIS PAGE IS INTENTIONALLY LEFT BLANK

7

General Design Requirements

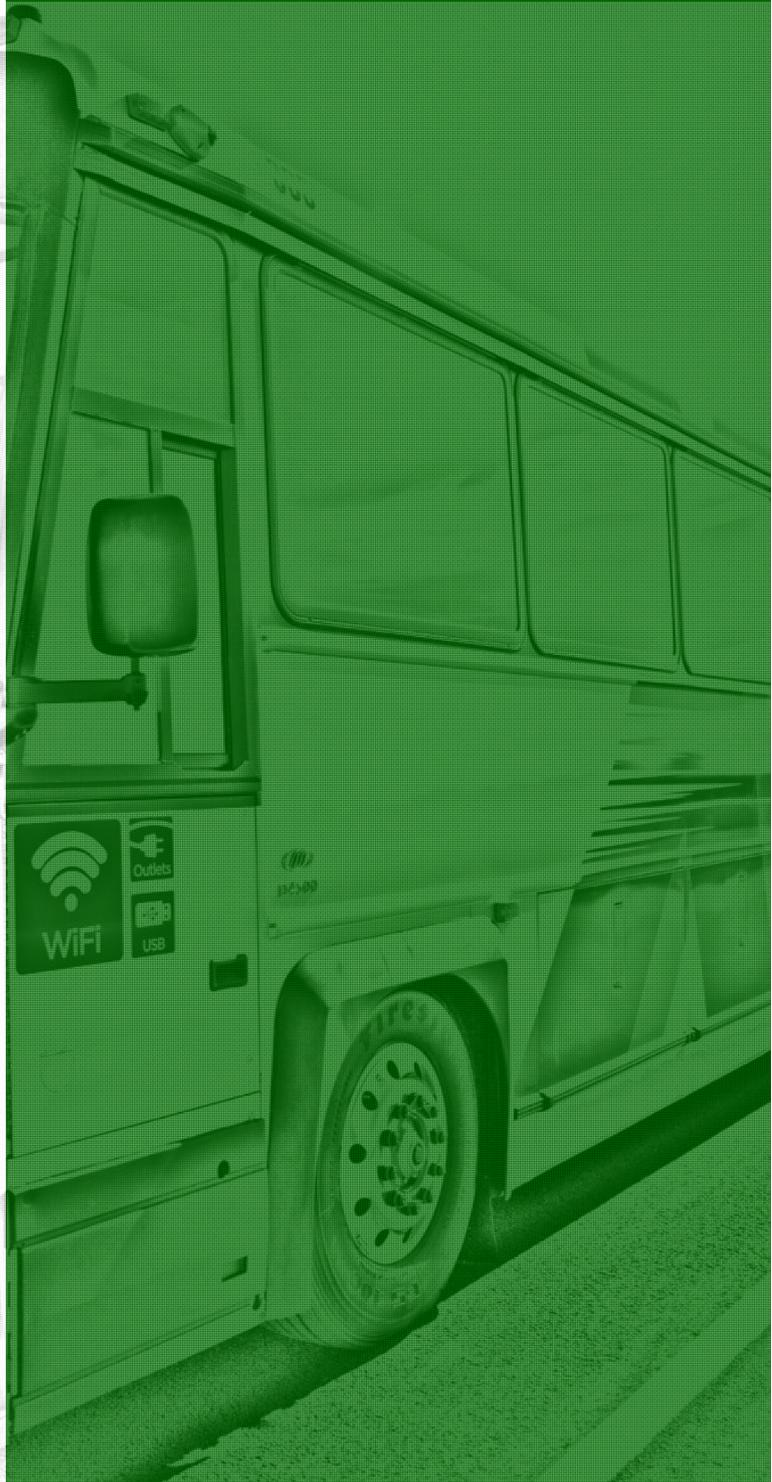

7. General Design Requirements

The following general design guidelines will apply to each park & ride facility.

7.1 Temporary Facilities

Temporary offices, storage sheds, trailers, barricades, fences and the like ("Temporary Facilities") will be reasonably permitted during the construction of a permanent building. Such Temporary Facilities must be fully contained on the Lot and shall be located as inconspicuously as possible and be no inconvenience or eyesore to the general public.

Construction Parking

7 All parking for construction and temporary personnel shall be contained entirely on the proposed development. Temporary personnel parking areas and access roads for use during the construction period shall be provided and maintained by the Contractor in a neat and orderly manner and in compliance with all applicable codes and ordinances.

Removal of Temporary Facilities

All Temporary Facilities shall be removed promptly as each becomes no longer required and the area completely cleaned of all debris, neatly dressed and shaped and temporarily grassed as required to stabilize the soil. No Temporary Facility shall remain more than thirty (30) days after the date of completion of the park & ride facility or the opening of the park & ride facility for use, whichever occurs first.

7.2 Planning for the Disabled

Facilities for use by the general public shall be planned to accommodate disabled persons, in accordance with Public Law 101-336, the Americans with Disabilities Act of 1990, (ADA) Accessibility Guidelines.

7.3 Environmental Protection

Pollutants Control

There shall be no noxious or offensive trades, services or activities conducted on the Lot nor shall anything be done thereon which may be or become an annoyance or nuisance to other Owners or Occupants by reason of unsightliness or excessive emission of fumes, odors, glare, vibration, gases, radiation, dust, liquid waste, smoke or noise.

Emissions Control

There shall be no emission of fly ash, dust, fumes, dirt, vapors or gases into the atmosphere from any operation to any extent that could result in damage to the public health, to animals, vegetation or to other forms of property. In no event shall there be any emission of solid or liquid particles in concentrations exceeding 0.3 grains per cubic feet of the conveying gas or air, nor of acid gases in excess of 0.2% by volume.

Gases, Liquids, and Sanitary Wastes Control

There shall be no emission of any odorous gas or material in such quantity as to be offensive beyond the boundaries of the site of such emission. There shall be no discharge of any liquid or solid waste into any stream, flood plain, wetland, storm sewer or any other portion of the development.

Smoke Control

There shall be no emission into the atmosphere of visible smoke. Incinerators are not permitted at any time, including during development. Burning of trash, debris, etc., during construction is prohibited.

8

Site Design Requirements



8. Site Design Requirements

8.1. Site Layout and Grading

The proposed buildings and landscape elements shall be placed on the development so that the existing topography and landscape shall be disturbed as little as possible, and so that the maximum number of desirable existing trees and other natural features will be preserved. Construction and development of the facility shall not adversely affect any developed or undeveloped properties. Finish grading shall be completed so as to prevent ponding or washing of water runoff on the development or onto adjacent properties. Drainage shall generally be away from the building and the drop off and pickup areas. Newly graded areas shall be protected against erosion.

8.2. Streets and Drives

Curb and Gutter

Integral formed in place or extruded concrete curb and gutter (GDOT Type 2) Figure 8.21, must be installed continuously at the perimeter of all streets, drives, parking areas and landscape islands. Concrete curb and gutter/concrete banding shall be constructed of minimum 3000 psi concrete according to details below. Concrete roll curb (GDOT Type 7) shall be installed at all median locations. Figure 8.22. Granite curbing shall be installed at the bus loading and unloading areas. Figure 8.24 and Figure 8.24A

Design Criteria

- A. Curb-cuts for access drives to and from the property shall not exceed thirty-five (35) feet in width (face to face) and should be designed to intersect adjacent streets or drives at right angles except right-turn-only curb cuts which shall be per local municipal and/or GDOT standards. Curb cuts shall have a minimum of twenty-five (25) foot radius returns or as otherwise required by code.
- B. All access drives must be paved with asphalt or other approved hard surface material in accordance with the depths and standards in Figure 8.27
- C. Access drives intended for truck and/or bus traffic shall be constructed in accordance with Figure 8.25
- D. Access drives must be graded to prevent surface storm drainage from flowing from the site onto adjacent public roadways/ right-of-way's.
- E. Parking areas that don't require large truck, bus, and fire truck vehicle traffic shall be constructed in accordance with the standard duty asphalt pavement section. Figure 8.26.

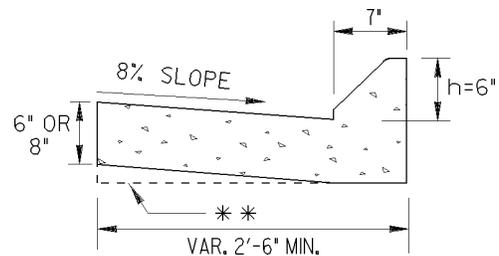

** AT CONTRACTOR'S OPTION THE GUTTER THICKNESS MAY BE INCREASED AT EDGE OF PAVEMENT TO MAKE BOTTOM OF GUTTER PARALLEL WITH PAVING OF BASE COURSE, BUT THE GUTTER THICKNESS MUST NOT BE LESS THAN THE SPECIFIED 6" OR 8" AT ANY POINT.

Figure 8.22 - GDOT Type 7 Rolled Concrete Curb and Gutter (Typical for median locations)

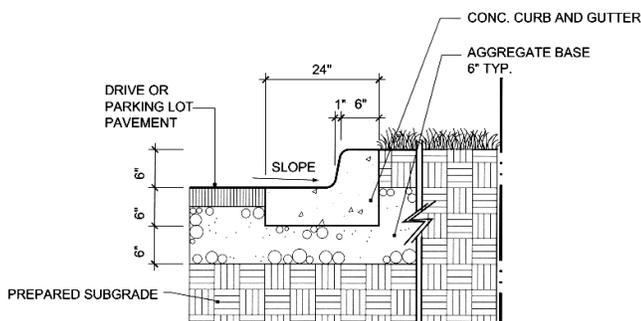

Figure 8.21 - GDOT Type 2 Concrete Curb and Gutter (Typical for drives/roads and parking areas)

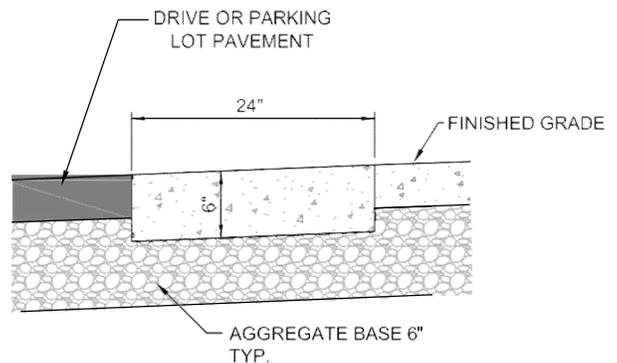

Figure 8.23 - 24" Wide Concrete Band (Typical for handicap parking spaces that do not require a ADA ramp.

CONTRACTOR TO PROVIDE SAMPLE OF ELBERTON GRANITE CURB FOR REVIEW AND APPROVAL BY LANDSCAPE ARCHITECT PRIOR TO ORDERING AND INSTALLING.

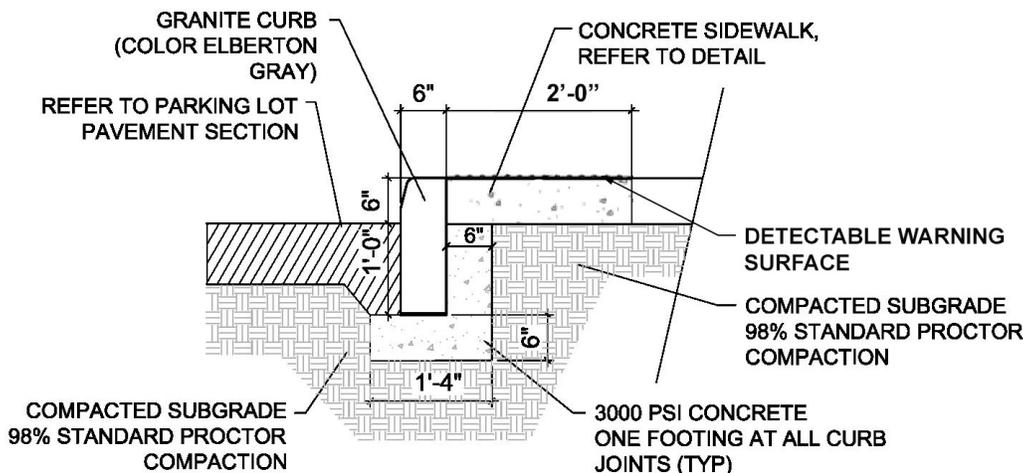

Figure 8.24 - Granite Header Curb
(Typical for Bus Loading and Unloading Locations)

CONTRACTOR TO PROVIDE SAMPLE OF ELBERTON GRANITE CURB FOR REVIEW AND APPROVAL BY ENGINEER PRIOR TO ORDERING AND INSTALLING.

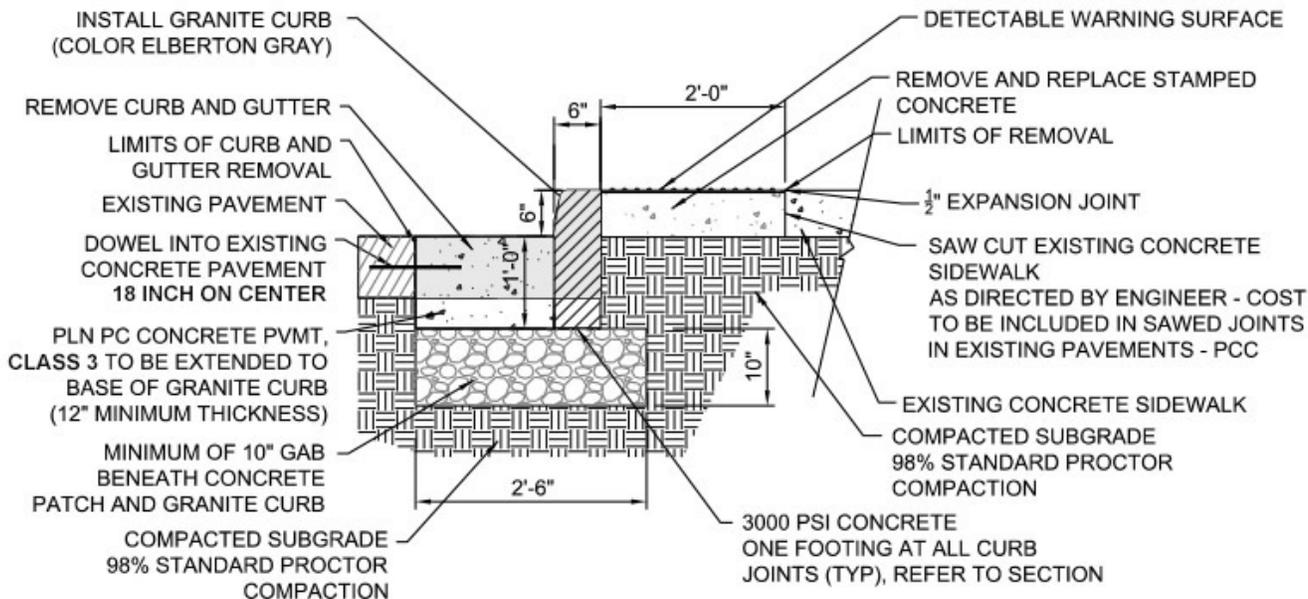

Figure 8.24A - Retrofit Granite Header Curb
(Typical for Bus Loading and Unloading Locations)

SRTA Recommended Roadway Design Criteria

Design Criteria	Entrance / Exit Drive Lanes	Bus Loading Areas
Maximum Design Speed	35 MPH	15 MPH
Maximum Grade	5% Desirable; 8% Max.	2%
Minimum Horizontal Curve Radii	See AASHTO Green Book	240 ft.
Maximum Superelevation	See AASHTO Green Book	2%
Crest Curves	See AASHTO Green Book	K=17
Sag Curves	See AASHTO Green Book	K=17
Minimum Intersection Angle	75 Degrees	75 Degrees

Entry Drives

Entry drives must be paved with medium duty asphalt Figure 8.27, or other approved hard surface material to conform to applicable governmental standards. Bus drop-off areas shall be concrete, Figure 8.25. Driveways that are owned by SRTA shall be asphalt, except where bus drop-off areas are located. Public Streets or dedicated right-of-way pavement design would be determined by local jurisdiction standards. Streets should be aligned horizontally and vertically for maximum safety and to minimize impact on existing topography, vegetation or other significant features.

The pavement sections and thicknesses may vary based on geotechnical recommendations. A geotechnical engineer shall evaluate each site and the existing soil conditions. The geotechnical engineer's recommendations will override the typical pavement sections below.

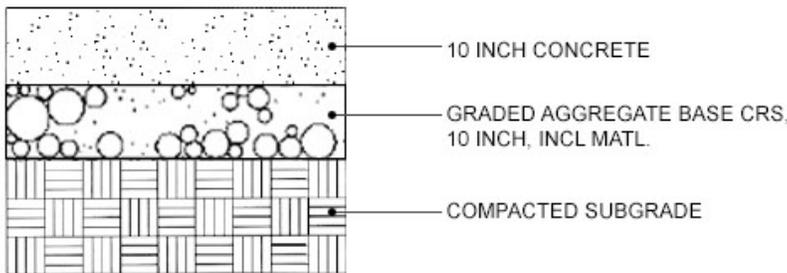

Figure 8.25 - Typical Concrete Paving on Aggregate Base
(Geotechnical Engineer's recommendations may alter typical pavement section)

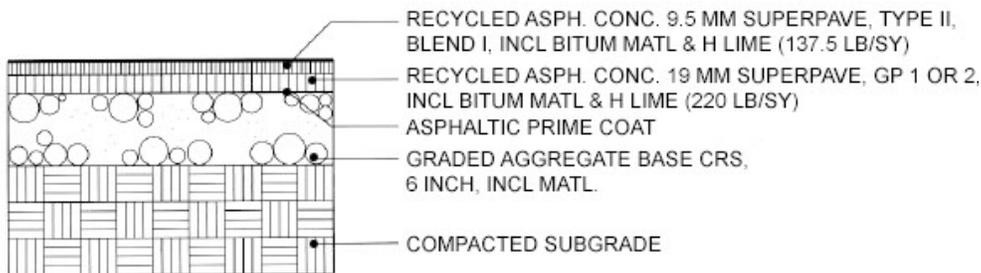

Figure 8.26 - Typical Asphalt Paving on Aggregate Base - Standard Duty
(Geotechnical Engineer's recommendations may alter typical pavement section)

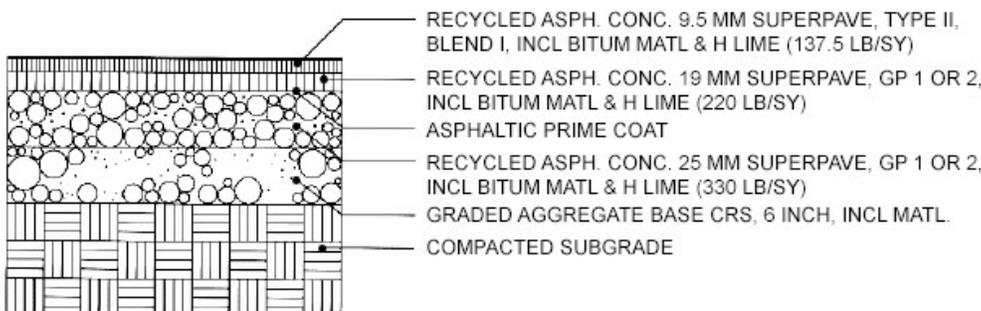

Figure 8.27 - Typical Asphalt Paving on Aggregate Base - Medium Duty
(Geotechnical Engineer's recommendations may alter typical pavement section)

8.3. Parking

Parking Layout

Parking must be provided as required by applicable governmental code(s).

It is preferable to orient drive aisle in such a manner so that pedestrians can walk toward shelters without walking between cars and crossing multiple drive isles. (Figure 4.31)

Parking spaces at a minimum should be (9) nine feet wide and (18) eighteen feet deep. Handicap spaces can be (8) wide with (5) five foot or (8) foot accessible aisle. Compact parking spaces may be provided for some of the parking per local code.

Parking Lot Wheel Stops

Parking lot concrete wheel stops are not recommended. If there are instances where they may be required to stop vehicles from blocking ADA accessible pathways they may be permitted only if secured to the existing pavement. Wheel stops shall be located a minimum of (2) two feet from face of curb to face of wheel stop. (Figure 4.32)

Standard Paving

Parking areas not designated for truck or bus traffic shall be paved with asphalt, or another approved hard surface material.

Painting and Striping

Parking spaces shall be marked with single white stripes. Handicap spaces shall be marked with blue handicap symbol. Pavement markings/striping require two coats; second coat applied 30 days after the first application. (Figure 3.33 to 3.38)

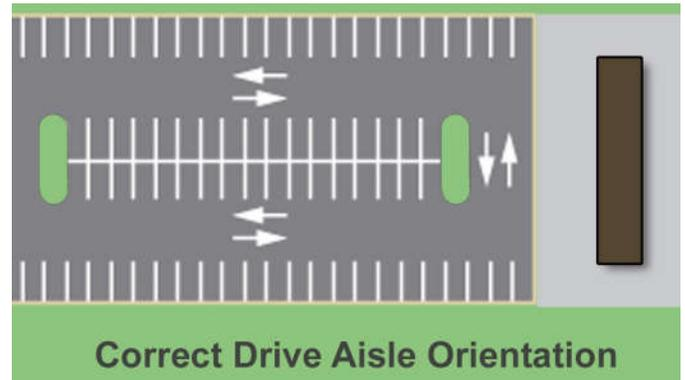

Correct Drive Aisle Orientation

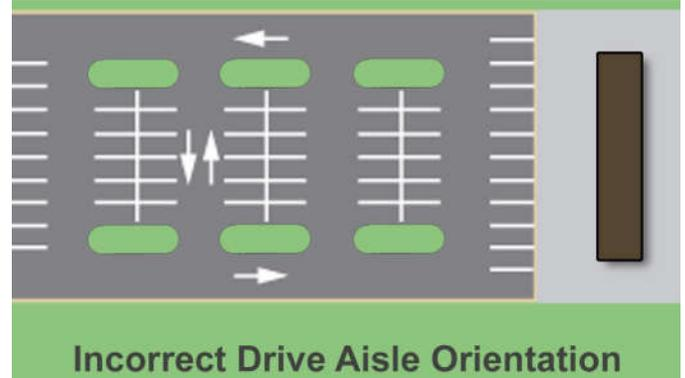

Incorrect Drive Aisle Orientation

Detail 8.31 - Drive aisle orientation

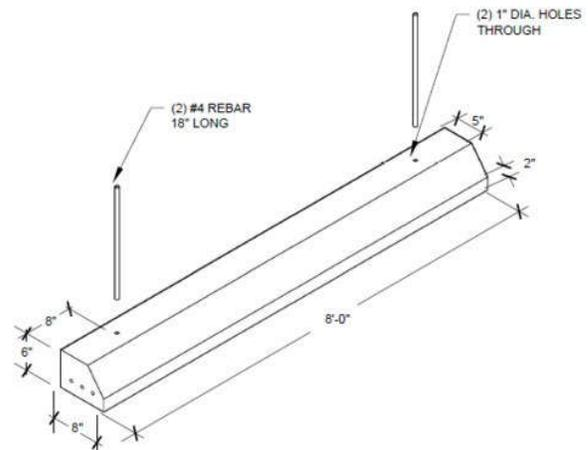

Detail 8.32 - Parking lot wheel stop detail

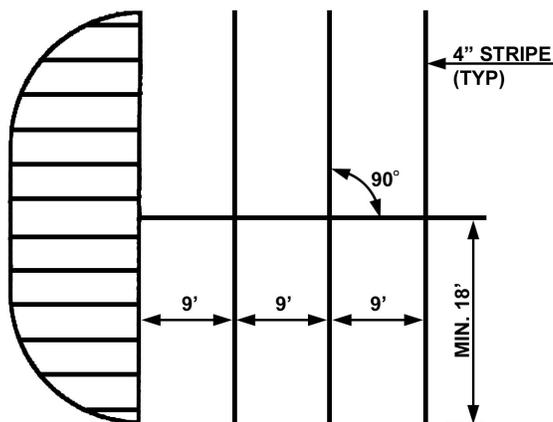

NOTE: PARKING SPACE DIMENSIONS SHALL ADHERE TO LOCAL MUNICIPAL CODE OR RECOMMENDED SPACING ABOVE.

Detail 8.33 - Striping Without Tree Island

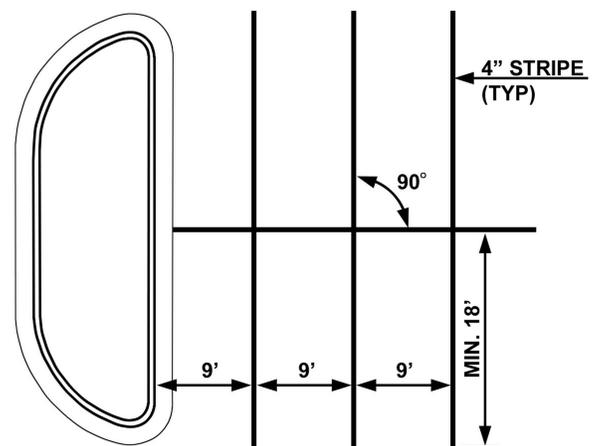

NOTE: PARKING SPACE DIMENSIONS SHALL ADHERE TO LOCAL MUNICIPAL CODE OR RECOMMENDED SPACING ABOVE.

Detail 8.34 - Striping with tree island

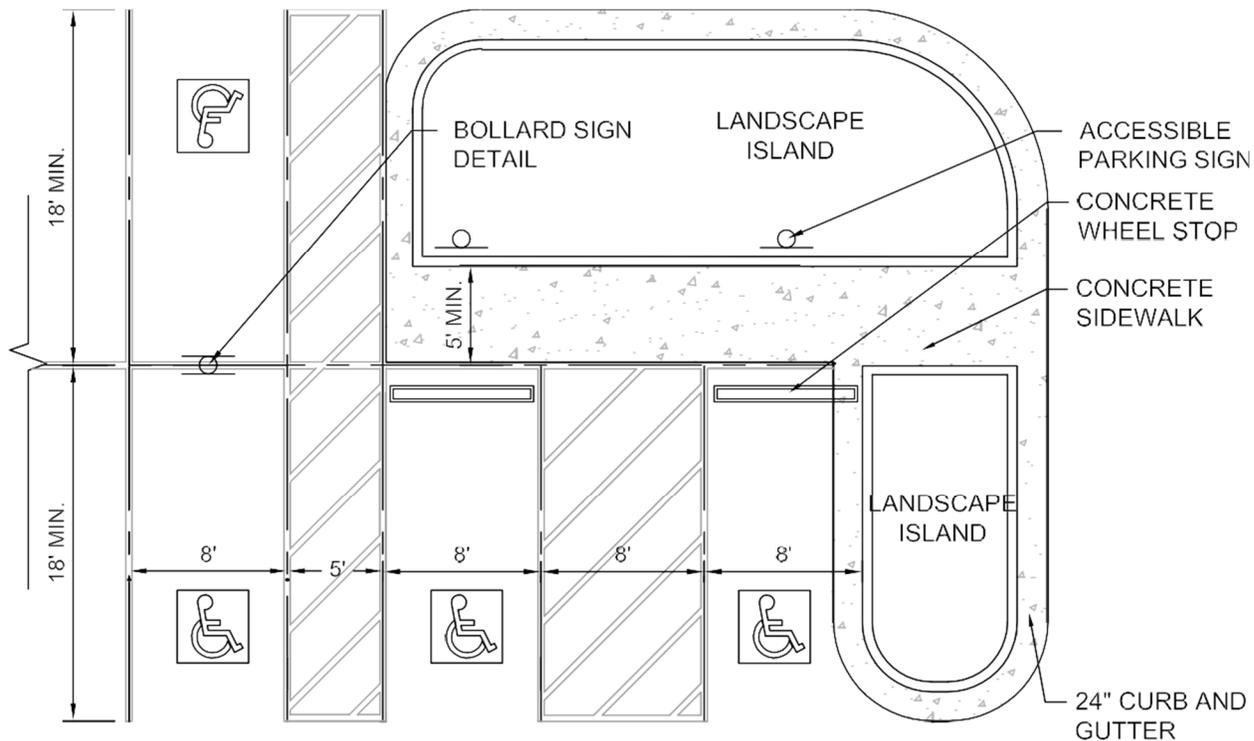

Detail 8.35 - Parking striping for double loaded handicap

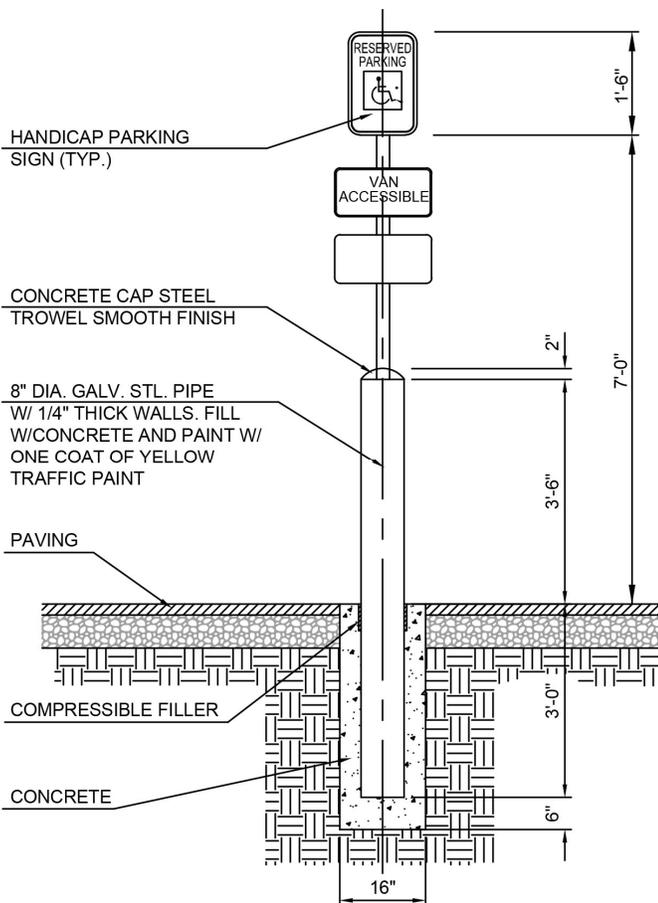

Detail 8.36 - Bollard with sign

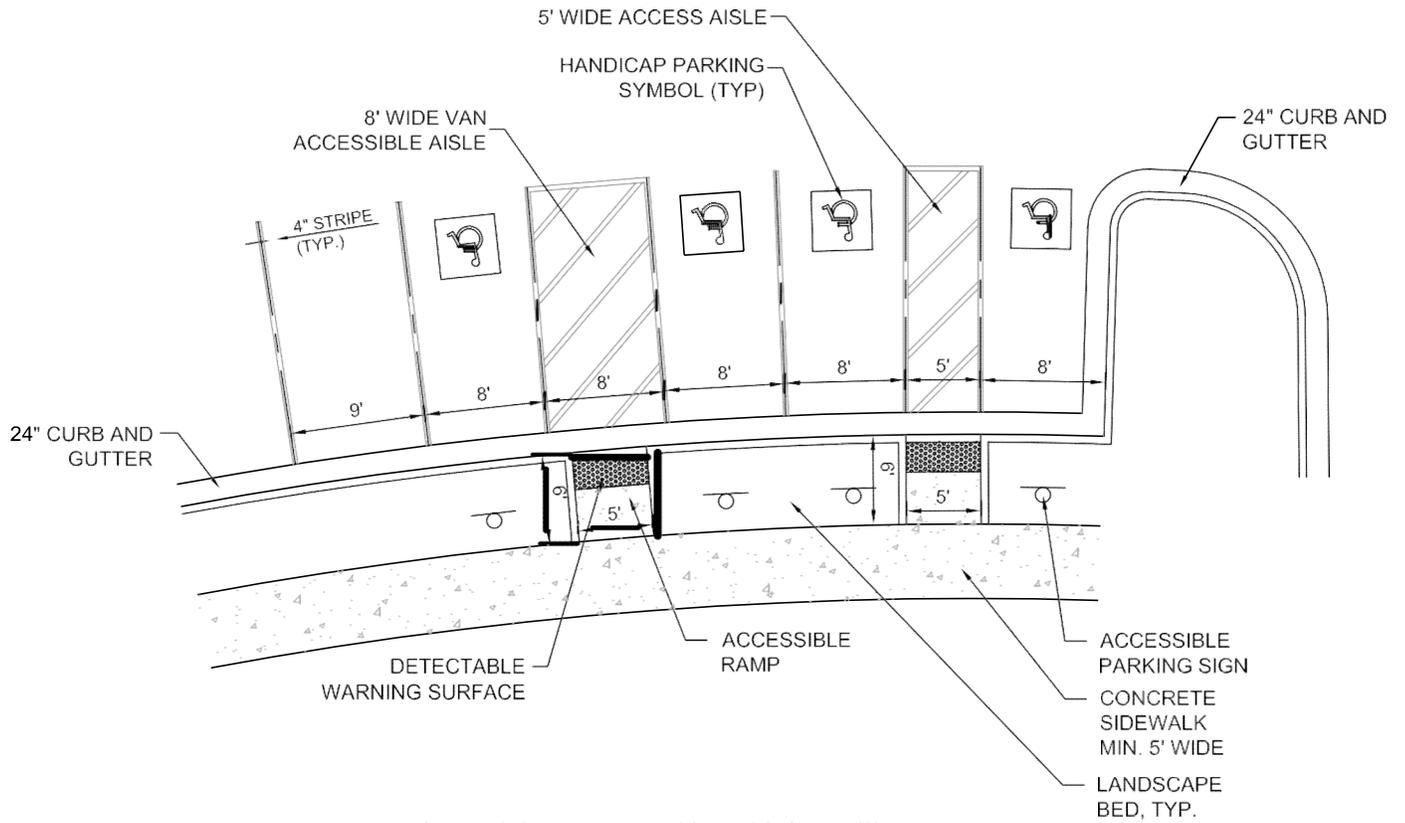

Figure 8.37 - ADA Parking striping with ramps

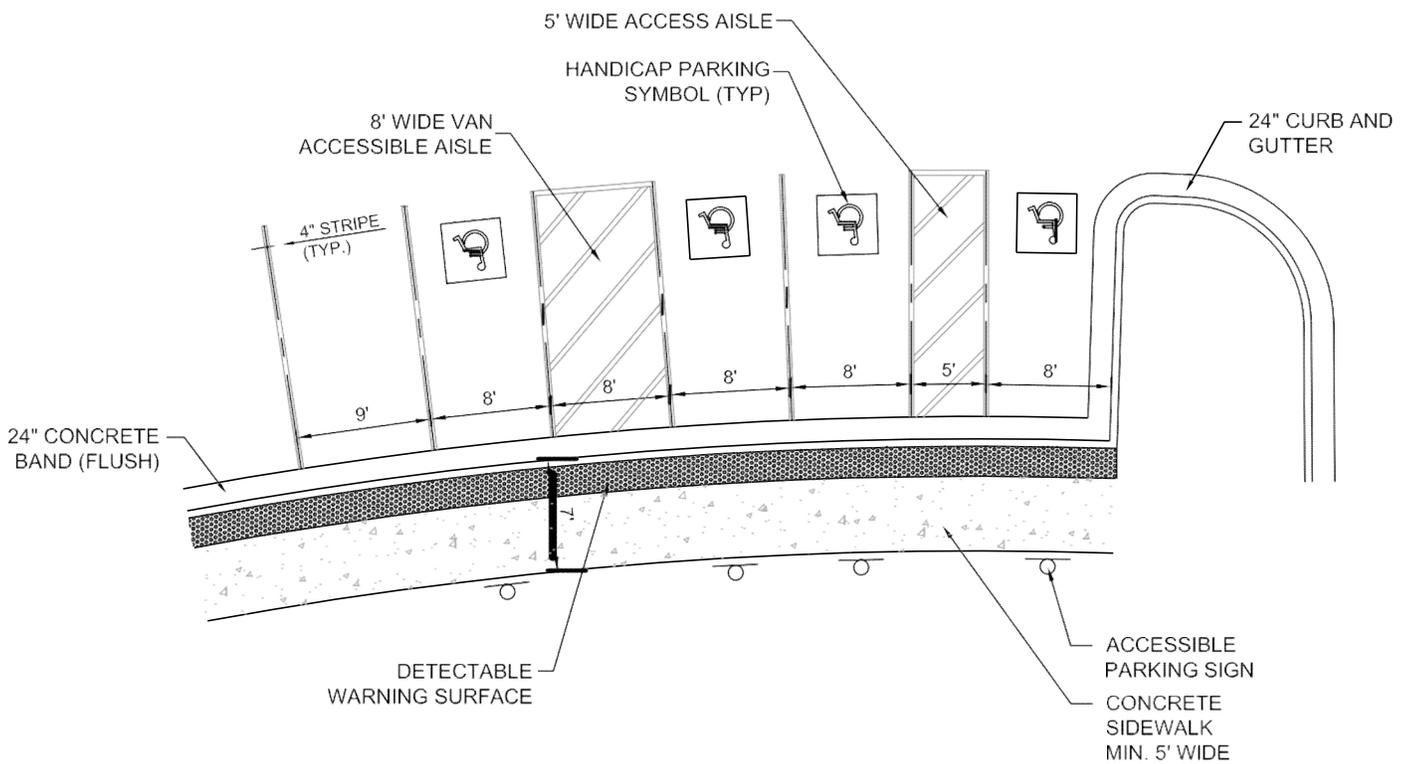

Figure 8.38 - ADA Parking striping without ramps

8.4 Sidewalk and Bus Plaza Design Criteria

Perimeter Sidewalks (along the right-of-way for connectivity), when required by local code, shall be constructed in accordance with the criteria specified in figure 8.41 and 8.42 and as follows:

1. To the extent possible, Perimeter Sidewalks should be aligned vertically and horizontally to minimize the impact on existing topography, vegetation and other desirable natural features of the site and adjacent properties.
2. All sidewalks must meet the accessibility standards for disabled use as required by applicable jurisdictional government agencies.
3. Positive drainage shall be provided so that stormwater runoff flows away from the pedestrian bus shelters and access paths.

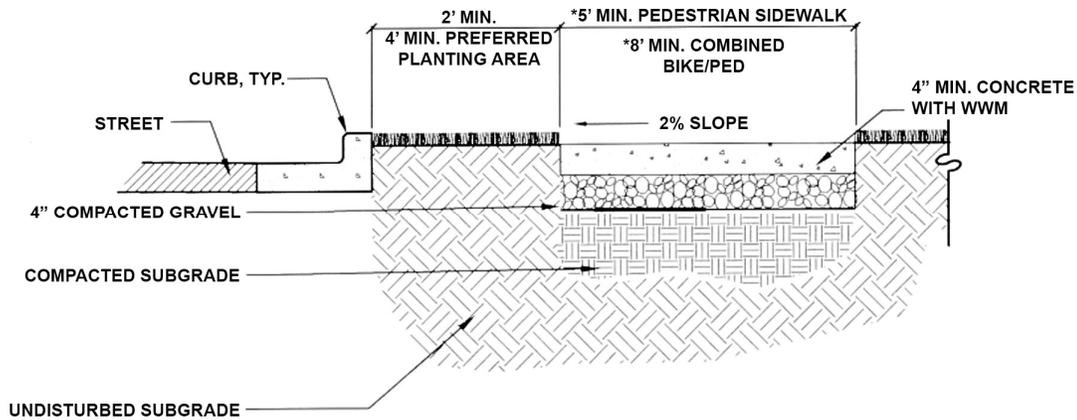
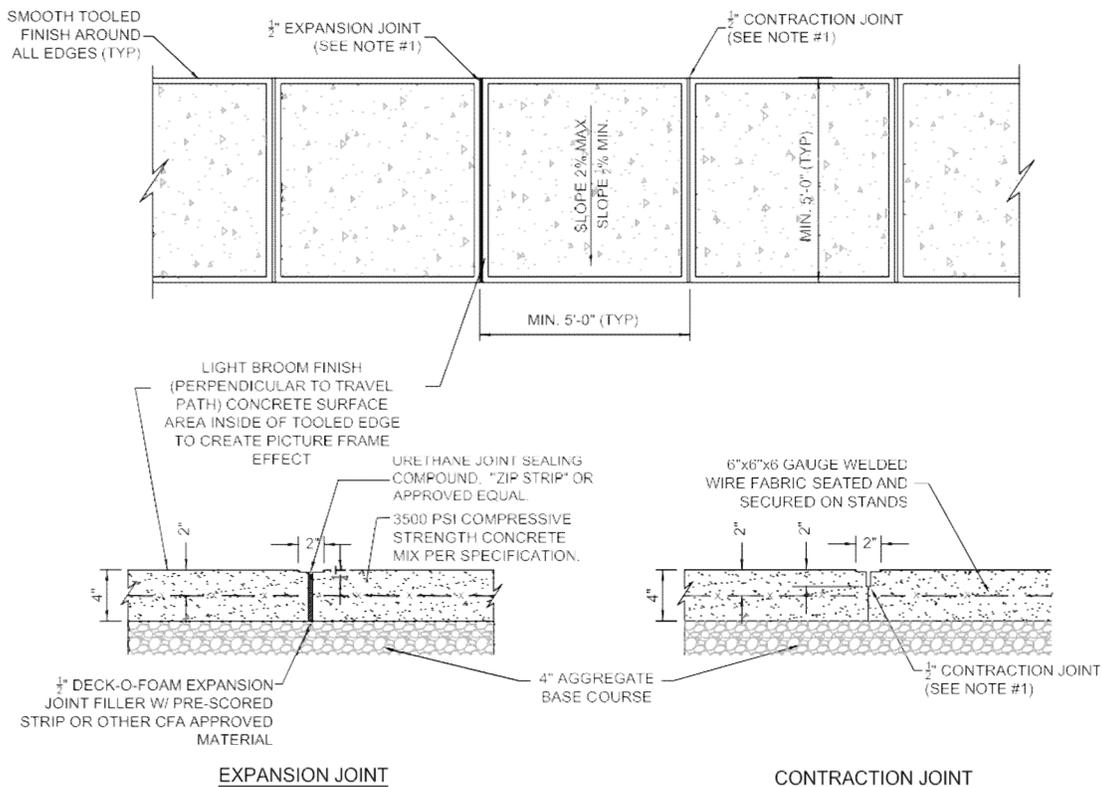

Figure 8.41 - Sidewalk cross section detail



NOTES

1. JOINTS AT 5'-0" O.C. TOOLED 3/8" WIDE, 1" DEEP OR MAX. 3/4" DEEP WHICHEVER IS GREATER. EXPANSION JOINTS AT 20' MAX. & ALL P.C.s, UNLESS APPROVED OR INDICATED OTHERWISE ON PLAN VIEW JOINT PATTERN. JOINT SPACING SHALL BE THE SAME WIDTH AS THE SIDEWALK WIDTH.

Figure 8.42 - Concrete sidewalk plan

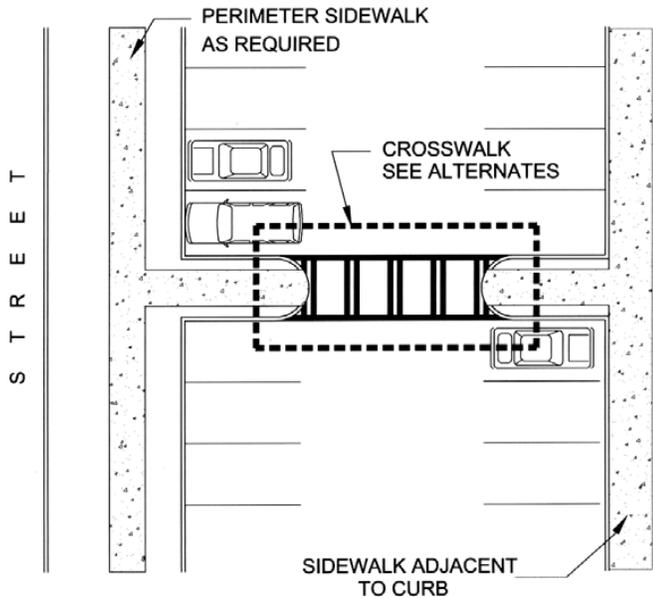

Interior Sidewalks

1. Sidewalks shall extend from the Perimeter Sidewalk system to the main bus drop off pickup areas.
2. Interior sidewalks must be constructed of concrete or other approved hard surface paving material. The use of brick, stone or unitized paver materials is encouraged to add aesthetic interest, especially at building entrances and pedestrian crosswalks and other intersections with vehicular transportation systems. Asphalt is not an approved sidewalk material.

Pedestrian Crosswalks

1. All crosswalks and other intersecting points between the pedestrian and vehicular traffic systems must be clearly marked in accordance with figure 8.43 as a minimum. The use of special approved brick, concrete, or stone materials or finishes to identify crosswalk areas is encouraged as shown in figure 8.44.

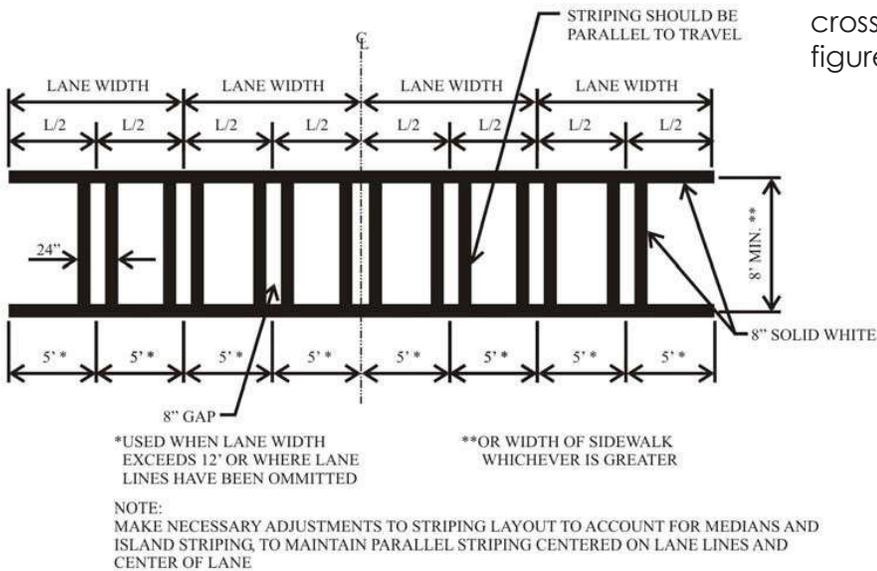

Figure 8.43 - Pedestrian crosswalk

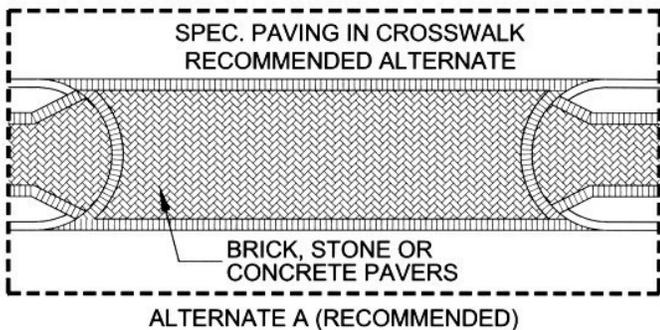

Figure 8.44 - Alternate paving design pedestrian crosswalk

8.5 Equipment and Utilities

Utility General Criteria

Other than approved satellite dishes, all Utilities must be installed under-ground, including telecommunications and primary and secondary electrical service, except (i) ground mounted electrical transformers; (ii) fire hydrants; and (iii) tie-ins, manholes and other surface access facilities.

Intelligent transportation systems (ITS) utility cabinets/components and maintenance/storage building shall be in proximity (approximately (50) fifty feet) to bus loading area. In some circumstances the ITS cabinets and maintenance/storage building location may be dictated by site specifics.

Stormwater Management System

Stormwater Detention Systems shall be designed to accommodate and manage storm water runoff for the development assuming a fully built-out condition. The storm water detention system shall be designed in accordance with the Georgia Stormwater Management Manual, latest edition, and/or local municipal standards, whichever is more stringent.

Stormwater discharge from the site must conform to all applicable local, state and federal laws, ordinances, codes, rules and regulations and the requirements of any permits issued in connection with the development, ownership or operation of the park & ride facility. The discharge of pollutants or other harmful material into the storm system or wetland areas is strictly prohibited.

On-site Design

Storm drain pipe material for sitework construction must be reinforced concrete pipe. The pipe classification must be determined based on the Georgia Department of Transportation requirements. Concrete pipe is to conform to ASTM C76. Concrete pipe shall have rubber gasket joints conforming to ASTM C443 or AWWA C302.

Retaining Walls

Structural retaining walls and decorative landscape walls should be designed and constructed as low as possible. Walls, which are exposed to public view, must be finished in granite indigenous to the area or brick or stone materials to match the exterior building materials. Stamped concrete in an ashlar finish or approved equal would also be acceptable. Designers to specify the finish on the retaining wall envelopes and details. Generally, walls shall utilize GDOT standards, however where special wall designs are required, they must be designed by a Registered Georgia Structural Engineer.

Setback Criteria

Building Setbacks must conform to local municipal; standards as well as any easements or setbacks required.

8.6 Construction Requirements

Pre-Construction

Prior to commencement of any clearing or construction, all required submittals must be received and approved in writing by the SRTA. Contractor must arrange a pre-construction conference with SRTA to discuss any special conditions or requirements such as the protection of existing improvements and the like.

Erosion Protection

Erosion protection during construction must comply with the local municipal and state standards and other applicable governmental requirements. Erosion protection requirements will be strictly enforced including maintenance of all erosion control devices during construction. In the event of siltation, runoff or erosion from development, the Contractor shall be responsible for the cleanup of said erosion or runoff and all costs associated therewith. Erosion control shall be designed in accordance to the latest Manual for Erosion and Sediment Control in Georgia. The contractor is also responsible for any fees assessed.

Stormwater Management During Construction

Sediment control basins must be provided and maintained during construction until such time as the permanent storm sewer system is in place. Erosion protection measures shall be strictly followed. Erosion control measures must be in compliance with the latest edition of the Manual for Erosion and Sediment Control in Georgia.

Construction Parking and Storage

All construction vehicles must be parked on the development and not on adjacent streets, roads or properties. All construction related materials must be stored and maintained on the development in a neat, orderly manner.

Construction Maintenance

1. Construction sites shall always be maintained in a neat and orderly manner throughout the construction process. All trash shall be kept in enclosed containers and emptied weekly or at such greater frequencies as may be required. All temporary fencing and barricades must be clean, neat, and well maintained.
2. All materials resulting from clearing, grubbing, grading or demolition shall be promptly removed from the site and disposed of in a legal manner. Burning is prohibited.

Construction Access

Construction access shall be coordinated with and approved by the SRTA. Special care shall be taken to protect existing pavements, landscape and other improvements from damage. Adjacent roadways must always be cleaned and maintained. If directed by any government agency having jurisdiction or the SRTA, the contractor shall provide a truck wash station to ensure that vehicles and roadways are kept clean.

Construction Damage and Repair

Any damage to any adjacent street, road, driveway curbs, utility, landscaping or other improvement resulting from the construction activities on any adjacent properties shall be immediately repaired or replaced by the Contractor.

9

Architectural Requirements



9. Architectural Requirements

9.1. General Criteria

The SRTA Plan is based on a comprehensive approach to development with respect to the intended character and integrity of the site features. The architectural character is an important part of preserving and protecting the image and value. To produce an orderly and aesthetically pleasing environment, architectural treatments and character must be approved by the SRTA, prior to any site disturbance or project construction. A building's exterior architectural expression and design compatibility with the neighboring areas are of primary concern. Architectural style, size, massing, spatial relationships, organization, detail, color, and material will be among the criteria used by the SRTA for evaluation. All exterior building elevations will be considered in determining acceptability of a design proposal. Particular attention should be given to those facades that are visible to public view and/or adjacent development.

The Applicant should strive to:

1. Create a structure with attractive, high quality exterior elevations on all sides utilizing finish materials that are resistant to vandalism, with ease of maintenance.
2. Provide an appropriate level of interest in the roofline.
3. Emphasize architectural detailing for "curb appeal" and positive visual impact, especially at building entrances.
4. Create and maintain site and architectural design character and quality in keeping with that of the surrounding areas.

Design features are to be in compliance with the requirements found in ADA Standards for Transportation Facilities, and local requirements. In some cases, variances to local design requirements may be needed to provide for the safety and security of facility users.

Figure 9.11 below is an example of the conceptual passenger bus shelter and figure 9.12 is an example of a storage building.

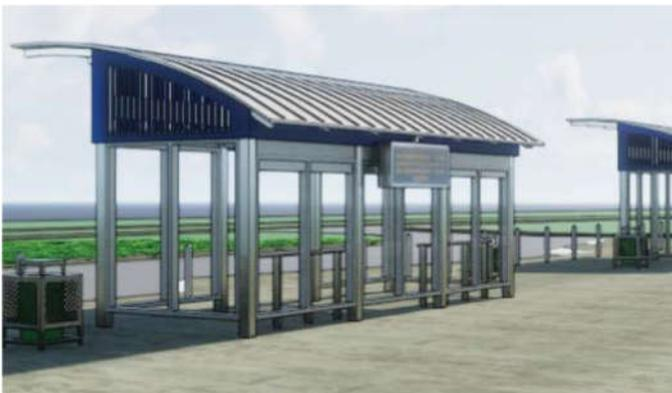

Figure 9.11 Conceptual rendering of bus shelter and storage building.



Figure 9.12 Conceptual rendering of storage building.

9.2. Setback Criteria

Building Setbacks must conform to the local jurisdictional standards as well as any easements or setbacks required pursuant to these Guidelines. Any applications for variance by the Applicant to the local jurisdictions must first be approved by the SRTA.

9.3. Height Limits

Building height limits must generally conform to the local jurisdictional standards but are subject to review and approval by the SRTA. Bus shelters and storage rooms are primarily single level with heights compatible with other site components. For other structures such as parking garages, a variance must be obtained from local jurisdictions and the SRTA for any building height in excess of five (5) stories. Any application for variance must first be approved by the SRTA.

9.4. Exterior Building Materials

Exterior materials shall conform to and be in harmony with the overall architectural theme as described throughout these guidelines, as well as the design of neighboring structures. The approval of exterior materials, including type, color, texture and durability as well as the extent of use of any single material or combination of materials, shall be solely at the discretion of SRTA. Large, uninterrupted expanses of a single

material is discouraged. Wherever possible buildings should be designed and arranged with offsetting surfaces and planes to provide a varied street appearance. Applicants shall prepare conceptual renderings of the intended design of any structural facilities to SRTA for approval before inclusion in final plans or fabrication. SRTA shall be involved early in the architectural design stages of the project to discuss architectural design, style, concept and

In general, bus shelters shall be constructed primarily of metal / stainless steel and impact resistant glazed wall panels. This supports the safety and security of patrons thru visibility. For other enclosed structures, each building elevation must be constructed of at least 50% approved brick or stone materials. Graffiti resistant materials shall be used as much as possible on applicable materials or coated, exposed surfaces. Dryvit, EIFS, stucco and similar materials are not permitted below eight (8) feet above grade in areas readily accessible to the public. In establishing a design theme, we encourage the use of natural materials and colors indigenous to the area. SRTA will adopt an architectural style of contrasting materials such as traditional stone with more modern glass and aluminum frame structures. Wherever possible throughout, structures and improvements on individual restricted lots should employ a complimentary architectural style. SRTA approved color palettes or Xpress service

color palettes are preferred. Recommended and prohibited exterior building materials are as follows:

Recommended Exterior Building Materials

1. Stone
2. Brick
3. Pre-cast Concrete Masonry Unit
4. Concrete Masonry Units (CMU)
5. Glazed or coated CMU
6. EIFS
7. EIFS Moldings
8. Glass

Prohibited Exterior Building Materials

1. Wood
2. Imitation Wood
3. Vinyl or Plastic
4. Corrugated Metal
5. Glass Block
6. Tent-type Tension Structures

9.5. Roof Design

To ensure the preservation of views, all rooftop surface material, color, texture, equipment and accessories shall be reviewed and approved by the SRTA according to the following guidelines:

- A. Radius, sloping or gabled roof designs are encouraged and preferred, wherever possible.
- B. Rooftop solar collectors, skylights, and other potentially reflective elements shall be designed and installed in a manner that prevents reflected glare and obstruction of views to and from other restricted lots and structures.
- C. Roof mounted radio, TV and microwave antennae and towers are prohibited (unless otherwise approved by the SRTA).
- D. Roofing materials, which are exposed to public view, shall be compatible in color with the building colors and materials within the surroundings. Recommended and Prohibited roof materials are as follows:

Recommended Roof Materials

1. Standing seam metal (mill finish, dark green, earth tone or other SRTA approved color)
2. Slate shingles
3. Clay or concrete tile
4. Fiberglass architectural profile shingles
5. Single-ply roof (only where not exposed to public view)

Prohibited Roof Materials

1. Corrugated metal
2. Tent-type tension structures
3. Wood shingles
4. White or other bright colored or highly reflective materials

9.6. Exterior Building Equipment

- A. Exterior building mounted equipment should be minimized. Where required, exterior building mounted equipment must be screened from public view or otherwise detailed to appear part of the architectural design.
- B. Ground mounted equipment must be screened in accordance with Sections 4.06 and 4.07.
- C. Detached buildings or structures must be designed and constructed to match the architecture and materials of the bus shelters.
- D. One (1) lockable or keyed hose bib shall be provided at the storage building for maintenance purposes. Location shall be determined per site design.

9.7 Exterior Building Lighting

Exterior building mounted and accent lighting should be selected to be compatible with the building architecture and the surrounding area. Fixtures must be located and aimed so as not to cause glare upon adjacent streets, drives, roads, sidewalks, parking areas or restricted lots. Use of low-pressure sodium light fixtures is prohibited. Refer to the Lighting Requirements narratives in section 11.0.

10

Landscape and Site Furnishing Requirements



10. Landscape and Site Furnishing Requirements

10.1. Introduction

The landscape treatment and amenities of each park & ride facility has a direct impact on the overall character of the development and functionality. A landscape plan shall be submitted to the SRTA and local governing authorities at the same time other plans are being reviewed (i.e. architectural design, lighting, parking, signage and site plans) for approval. This plan shall be drawn to scale, shall delineate all existing and proposed structures, parking areas, walks, ramps for handicapped access, pedestrian plazas, driveways, signs, lighting standards, steps, walls, and othersimilar structures; and shall delineate the location, size, and description of all landscape materials. Landscape treatment for plazas, roads, paths, service and parking areas shall be designed as an integral and coordinated part of the landscape plan for the entire property. Detailed information may be requested by the SRTA and local governing authorities to obtain the final approval.

To preserve the desired level of quality throughout each park & ride it is important that the landscape design, installation and maintenance be consistent. To accomplish this objective the following landscape criteria shall be adhered to as a minimum for each park & ride facility.

10.2. Landscaping Design Objectives

1. Planting design should generally reinforce the design objectives of the facility and help to articulate the pedestrian and vehicular circulation systems.
2. Provide clear sight lines which do not impede visibility to transit waiting passengers, transit vehicles in the travel way, and vehicular traffic entering or exiting the site.
3. Avoid creating areas of concealment with landscape materials for security reasons.
4. Avoid interference with pedestrians, bicycle, bus and auto paths.
5. Discourage vandalism.
6. Be easily accessible for maintenance.
7. Plant materials must be of a size, species and variety specified on the Recommended Plant List (below). Shade and Street Trees must be a minimum of 3"-3 ½" caliper.
8. Evergreen Trees must be of a species specified on the Recommended Plant List and shall be a minimum height of nine (9) feet. Evergreen trees should be used in masses for general background planting, screening, and framing of buildings or views. Evergreen Trees may also be used as massed, free standing elements for special effects. Evergreen trees massed to screen views into the parking lot and development from adjacent properties is recommended. Evergreen trees shall be located where they still allow visibility from adjacent streets.
9. Flowering Trees must be of a species specified on the Recommended Plant List, shall be a minimum of two-and one-half-inch caliper (2 ½") and should be grouped in randomly arranged clusters as foreground plantings or grouped for accents or other effects. Single specimens may also be used as focal points.
10. Evergreen or deciduous shrubs should be massed for screening, background plantings or foundation planting. Where appropriate, single plants or small groupings may also be used as freestanding elements.
11. Groundcovers or other approved permanent shrub and/or tree planting combinations shall be used on all slope's steeper than two to one (2:1). They may also be used in flat areas either alone or in combination with other plant materials for a massed effect and to aid in erosion control. Ground cover shall be used in tree planting islands in the parking lot to reduce the amount of mulch needed after groundcover has established.
12. Perennial flowers are encouraged to provide visual accent at key interest points such as pedestrian or vehicular access points, pedestrian plaza, monument signage, main entrance plantings, and building entrances.
13. Screening of service yards, exterior utilities (includes utility cabinets, generators, and condensers, etc.) refuse collection areas and other places which tend to be unsightly shall be accomplished using walls, fencing, landscaping or any approved combination

of these. Screening shall be effective in winter and summer seasons. Shield vehicular parking areas, service areas and driveways from adjacent properties using effective screening mechanisms such as: landscaped earthen berms; lowering the parking level grade below sight lines and using evergreen screen plantings.

14. Every effort shall be made to respect and preserve existing Specimen Trees on site.

10.3. General Landscape Criteria

1. Selectively preserve existing vegetation and provide new plantings to afford a balanced environment for the park & ride lot user.
2. All outdoor portions of the park & ride facility (including easements and rights-of-way) not covered by structures or paving must be completely planted with approved sod grass and plant materials. Large areas of uninterrupted mulch or gravel are not acceptable.
3. Use context-sensitive design to reflect the character of the area.
4. Plant material shall have an emphasis on a low-maintenance, shall be of a variety that is indigenous to the surrounding area, and appropriate to Georgia climate and soils, to ensure establishment and long-term success.
5. Landscape planting plans must be prepared for each park & ride by a Landscape Architect registered in the State of Georgia and shall include a description of the plant material species and required sizes.
6. Tree, shrubs and groundcover materials should be selected from the Recommended Plant List (below) unless otherwise approved by SRTA or local jurisdiction. Grassed areas must be seeded or sodded with Bermuda, Zoysia or Tall Fescue (Recommended Plant List). Turf grassed areas shall be minimized as much as possible to help reduce maintenance.
7. A low mow native grass or wildflower seed mix may be used in areas that are difficult to mow (slopes) and areas where turf grass could be minimized.
8. Approved landscaping must be installed prior to opening, although trees should be planted in the appropriate planting season to ensure establishment.

9. Specimen tree that is of particularly impressive or unusual example of a species due to its size, species, shape, age, or any other trait that epitomizes the character of the species, and which meets the following DBH (diameter at breast height):

- 9" DBH – Small trees (dogwood, redbud, sourwood, cherry, etc.)
- 24" DBH – Overstory hardwoods (oak, elm, sweet gum, etc.)
- 32" DBH – Overstory softwoods (pine, etc.)

10. The site density factor shall comply to local code. If no local code exists, the total site density factor (existing and proposed trees) shall be no less than 40 caliper inches per acre are required. Applicant shall submit a plan that identifies the specimen trees to be removed, the specimen trees to remain in place and the proposed trees to meet the site density factor.

11. No trees, especially crape myrtles (*Lagerstoemia indica*), shall be topped. Proper pruning techniques include removing suckers from the bottom, but NEVER the top of the trees canopy. If trees are topped, such trees shall immediately be removed from the site and replaced with the same variety and size tree at the contractor's expense. All maintenance contractors shall be made aware of this requirement.

12. Full coordination is required between the landscape architect and the lighting engineer to prevent the tree foliage from blocking the light distribution from the site luminaire thus providing dark spots and not meeting the required illumination level.

10.4. Recommended Plant List

The following list constitutes the recommended plant material for the Xpress park & ride facilities. The landscape plan shall comply with local ordinance and standards.

Small Flowering/Ornamental Trees (less than 30 feet tall at maturity)

Common Name

Trident Maple
Autumn Brilliance Serviceberry
Eastern Redwood
Fringe Tree
Kousa Dogwood
Flowering Dogwood
Crape Myrtle
Saucer Magnolia
Flowering Crabapple
Goldenrain Tree
Japanese Flowering Cherry
Chaste Tree

Scientific Name

Acer buergerianum
Amelanchier x g. 'Autumn Brilliance'
Cersis canadensis
Chionanthus virginicus
Cornus kousa
Cornus florida
Lagerstroemia indica
Magnolia x *soulangiana*
Malus species
Koelreuteria paniculata
Prunus serrulata
Vitex agnus-castus

Shade/Street Trees

Common Name

Red Maple
River Birch
European Hornbeam
American hornbeam
White Oak
Southern Red Oak
Overcup Oak
Nuttall Oak
Willow Oak
Northern Red Oak
Shumard Oak
Bald Cypress
Winged Elm
Chinese / Allee Elm

Scientific Name

Acer rubrum 'October Glory'
Betula nigra 'Dura-Heat'
Carpinus betulus
Carpinus caroliniana
Quercus alba
Quercus falcata
Quercus lyrata
Quercus nuttallii
Quercus phellos
Quercus rubra
Quercus shumardii
Taxodium distichum
Ulmus alata
Ulmus parvifolia

Evergreen Trees

Common Name

Deodar Cedar
Japanese Cedar
Foster Holly
American Holly
Nellie R. Stevens Holly
Fragrant Tea Olive
Pine
Chinese Arborvitae

Scientific Name

Cedrus deodara
Cryptomeria japonica 'Yoshino'
Ilex x *attenuate* 'Fosteri'
Ilex opaca
Ilex x 'Nellie R. Stevens'
Osmanthus fragrans
Pinus (Slash, White, Loblolly, Virginia)
Thuja orientalis

Recommended Shrubs

Common Name

Rosecreek Abelia
 Korean boxwood
 Beautyberry
 Camellia
 Japanese Camellia
 Spreading Plum Yew
 Winged Euonymus
 Gardenia
 Panicle Hydrangea

 Oakleaf Hydrangea
 Burford Holly
 Dwarf Burford Holly
 Carissa Holly
 Chinese Holly
 Compacta Holly
 Helleri Holly
 Winterberry
 Dwarf Yaupon Holly
 Sunshine Ligustrum
 Loropetalum
 Otto Luyken Laurel
 Knock Out Roses
 Drift Rose
 Azalea
 Bridalwreath Spirea
 Arrowwood Viburnum

Scientific Name

Abelia grandiflora 'Rosecreek'
 Buxus microphylla 'koreana'
 Callicarpa americana
 Camellia sasanqua
 Camellia japonica
 Cephalotaxus harringtonii 'Prostrata'
 Euonymus alatus 'Compactus'
 Gardenia jasminoide
 Hydrangea paniculate
 ('Limelight', 'Little Lime', 'Pinky Winky')
 Hydrangea quercifolia
 Ilex cornuta 'Burfordii'
 Ilex cornuta burfordii "Nana"
 Ilex cornuta 'Carissa'
 Ilex cornuta "Rotunda"
 Ilex compacta
 Ilex crenata 'Helleri'
 Ilex verticulata
 Ilex vomitoria "Nana"
 Ligustrum sinense 'Sunshine'
 Loropetalum 'Shang-hi', 'Crimson Fire'
 Prunus laurocerasos 'Otto Luyken'
 Rosa Knock Out varieties (NOT Red)
 Rosa Drift varieties
 Rhododendron sp.*
 Spirea prunifolia
 Viburnum dentatum

Recommended Groundcovers/Perennials/Ornamental Grasses

Common Name

Blue False Indigo
 Feather Reed Grass
 Sedge
 Autumn Fern
 Daylily
 Siberian Iris
 Blue Rug Juniper
 Shasty Daisy 'Becky'
 Big Blue Lilyturf
 Lilyturf
 Maiden Grass
 Regal Mist Pink Muhly Grass
 Pachysandra
 Fountain Grass
 Black-Eyed Susans
 Mexican Feather Grass
 Asiatic jasmine
 Periwinkle

Scientific Name

Baptisia australis
 Calamagrostis 'Karl Foerster'
 Carex sp.
 Dryopteris erythrosora 'Brilliance'
 Hemerocallis sp.
 Iris siberica 'Caesar's Brother'
 Juniperus horizontalis
 Leucanthemum x 'Becky'
 Liriope muscarii
 Liriope spicata
 Miscanthus sinensis 'Gracillimus'
 Muhlenbergia capillaris 'Lenca'
 Pachysandra terminalis
 Pennisetum alopecuroides 'Hameln'
 Rudbeckia 'Goldsturm', or 'Indian Summer'
 Stipa tenuissima
 Trachelospermum asiaticum
 Vinca minor

Recommended Vines (For use on retaining walls or structures that may require screening)

Common Name

Clematis
 Trumpet Honeysuckle
 Virginia Creeper
 Lady Banks Rose
 Confederate Jasmine
 Climbing Fig

Scientific Name

Clematis sp.
 Lonicera sempervirens
 Parthenocissus quinquefolia
 Rosa banksiae
 Trachelopermum jasminoides
 Ficus pumila

Recommended Turf Types

Location:

Sunny
 Shaded Areas
 Sun/Shade

Turf Name:

Bermuda Grass Tif Tuf
 Tall Fescue, "Rebel"
 Zoysia Grass varieties

Recommended Native Grass and Wildflower Mix

Common Name

Weeping Lovegrass
 Little Bluestem
 Virginia Wildrye
 Purpletop
 Broomsedge
 Butterfly milkweed
 Common milkweed
 New England Aster
 Tickseed
 Purple Coneflower
 Gayfeather
 Lupine
 Black-eyed Susan
 Goldenrod
 Blanket Flower
 Gaura
 Ironweed, Prairie

Scientific Name

Eragrostis curvula
 Schizachyrium scoparium
 Elymus virginicus
 Tridens flavus
 Andropogon virginicus
 Asclepia tuberosa
 Asclepias syriaca
 Aster novae-angliae
 Coreopsis lanceolata
 Echinacea sp.
 Liatris spicata
 Lupinus perennius
 Rudbeckia hirta
 Solidago rigida
 Gallardia aristata
 Gaura lindheimeri
 Vernonia fasciculata

10

Recommended Detention Basin Grass Mix

Common Name

Alisma subcordatum
 Asclepias incarnata
 Bidens aristosa
 Carex stipata
 Carex vulpinoidea
 Elymus virginicus
 Eleocharis species
 Glyceria striata
 Juncus effusus
 Juncus tenuis
 Leersia oryzoides
 Mimulus ringens
 Panicum virgatum
 Penthorum sedoides
 Scirpus validus
 Spartina pectinata
 Rudbeckia laciniata
 Verbena hastata

Scientific Name

Water Plantain
 Swamp Milkweed
 Tickseed Sunflower
 Awi-Fruited Sedge
 Fox Sedge
 Virginia Wildrye
 Spike Rush
 Fowl Manna Grass
 Soft Rush
 Path Rush
 Rice Cut Grass
 Allegheny Monkeyflower
 Switchgrass
 Ditch Stonecrop
 Softstem Bulrush
 Prairie Cordgrass
 Cutleaf Coneflower
 Blue Vervain

10.5. Parking Lot Landscape

Employing plant materials within the parking lots can reduce the visual impact of an expanse of paving materials and enhances the surrounding area by increasing the ratio of green open space to the impervious areas. Planting Islands can also reduce the urban heat factor and provide shade to enhance the site appearance. Parking facilities are required to provide the following amount of internal landscape:

1. Shade or street trees must be provided within all parking lot areas at the following ratio or according to the local ordinance requirements, whichever is more stringent:

Parking Spaces	Trees Required
10-50 spaces	1 tree per 8 spaces
50-100 spaces	1 tree per 10 spaces
over 100 spaces	1 tree per 12 spaces

2. Trees must be planted in landscaped islands with be a minimum of two-hundred (200) square feet of soil surface space.
3. Each planting island shall be excavated to a minimum depth of 36" and backfilled with good friable soil. The purpose of this is to provide each tree with enough soil capacity to ensure success and longevity. Landscaped islands should be provided at the ends of parking bays wherever possible.
4. Trees planted around the perimeter of parking lot shall align with the parking stripe and set behind the curb a minimum of 5', to prevent vehicles from injuring the tree trunk.
5. At least 50% of the total linear length of any parking area facing along any street or road must be landscaped with evergreen shrubs at least 18 inches in height and maximum of 4 feet in height as part of a planting buffer. Figure 10.51.

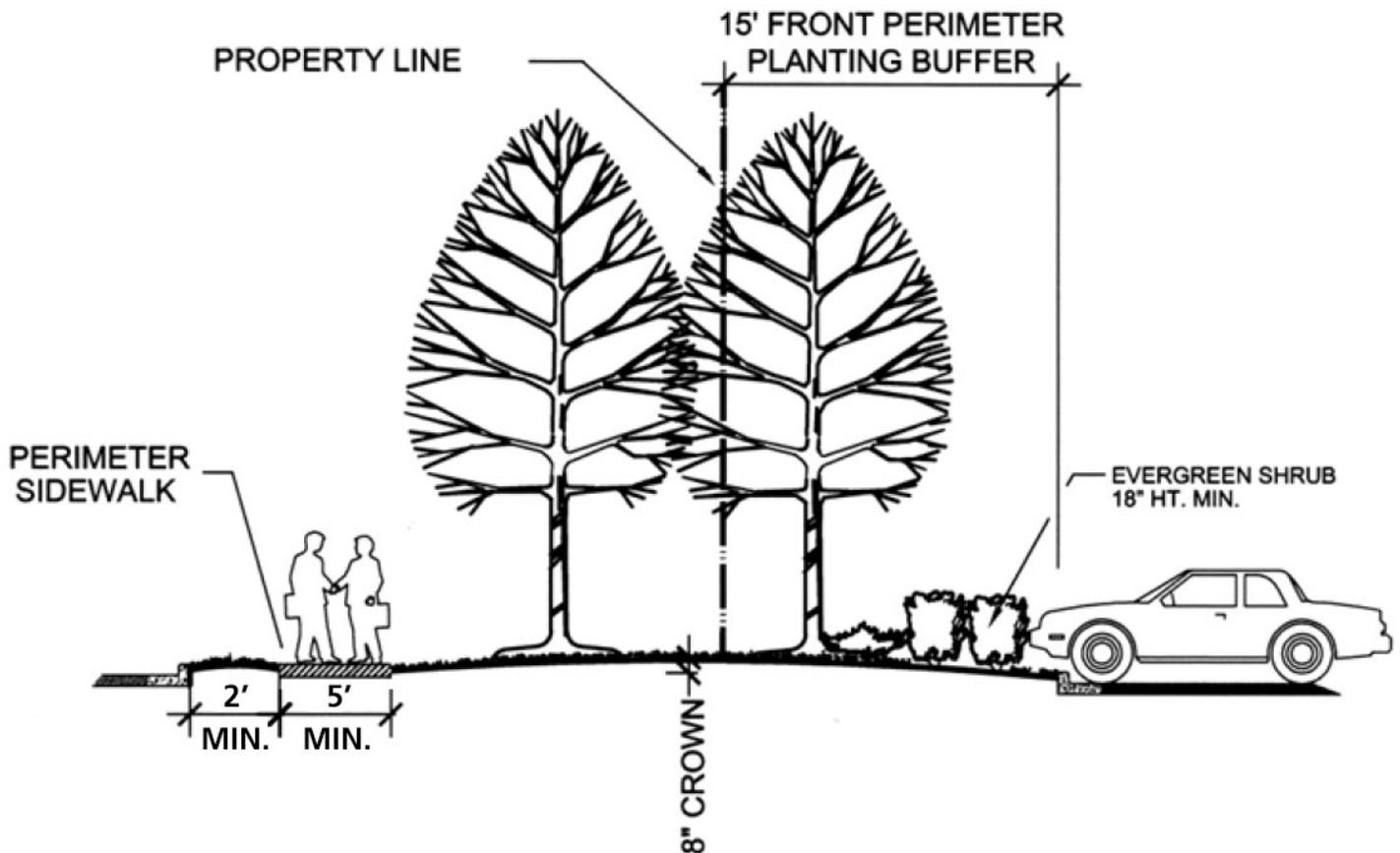

Figure 10.51 Parking Lot Landscaping

10.6. Landscape Irrigation

All plants and grassed areas require water (including parking lot islands). Plant selections should be such that once established require minimal watering. Plant establishment varies depending on the plant type, but usually occurs when plants and grassed areas are well rooted into the soil.

All landscape areas must be watered with temporary watering devices or hand watered by the contractor weekly if there is no significant rainfall within that week. Contractor to provide watering as needed to sustain healthy plant growth until final acceptance plus the one (1) year maintenance bond period. A soil moisture sensor shall be used to ensure the plant material is getting an appropriate amount of water and not too much water. Water shall be applied at rates to equal a minimum of one (1) inch per week. The (1) inch per week is a requirement for temporary irrigation for the plant establishment period. Once plants are established; minimal water will be required other than what is provided naturally with rainfall.

10.7. Landscape Maintenance

Contractors shall include a one (1) year maintenance bond starting after final acceptance of the project. The property shall always be maintained in a neat and orderly manner during the maintenance bond phase. Planting beds shall be kept weed free and in good health. Plantings shall be inspected periodically. If plantings die, they shall be removed and

replace with the same variety and size as specified on the plans for a guarantee period of one (1) years after final inspection. Lawn shall be mowed weekly during the growing season and edged every other mowing. Walkways, Pedestrian Plaza and the parking lot shall be blown weekly. Trash shall be removed from the property (lawn, planting beds and the parking lot, etc.). Trash receptacles shall be emptied weekly or at greater frequencies as may be required. Mulch shall be top dressed twice per year, in the spring and fall. Fall leaves shall be blown and removed as needed. Plantings shall be fertilized with a time released fertilizer each spring and pre-emergent applied. Fire Ant and pest control shall be provided on an as needed basis.

Spring Cleanup Tasks: Cut back perennials and ornamental grasses that remained through the winter, mow liriopie beds, prune deadwood from trees and shrubs, weed beds, apply pre-emergent, top dress mulch.

Fall Cleanup Tasks: Cut back perennials that do not have aesthetic appeal through the winter after first hard frost, weed beds, top dress mulch. (Perennials such as Black-Eyed Susan and ornamental grasses shall remain through the winter and shall be cut back during Spring Clean Up. Perennials such as Iris and Shasta Daisies shall be cut back during Fall Clean Up.)

Refer to schedule below for recommended monthly maintenance.

Month	Mowing (no. of times)	Edging (no. of times)	Fertilizing Lawn (no. of times)	Fertilizing Plant Beds (no. of times)	Spring Cleanup (no. of times)	Fall Cleanup (no. of times)	Pre-emergent Lawn (no. of times)	Trash/Debris Removal (frequency)	Leaf Removal
January	1	0					0	Bi-weekly	As needed
February	1	0			1		1**	Bi-weekly	
March	2	1		1			0	Bi-weekly	
April	4	2	1				0	Weekly	
May	4	2					0	Weekly	
June	4	2	1				0	Weekly	
July	4	2					0	Weekly	
August	4	2	1				1**	Weekly	
September	4	2					0	Bi-weekly	
October	2	1					0	Bi-weekly	As needed
November	1	0				1	0	Bi-weekly	As needed
December	1	0					0	Bi-weekly	As needed

** Timing of Pre-emergent herbicide application shall be at the discretion of the client to achieve desired results.

Figure 10.71 - Recommended monthly maintenance schedule

10.8. Site Furnishings

Site furnishings such as benches, leaning rails, blast resistant trash receptacles, bicycle racks, bollards and wayfinding information should be provided near pedestrian bus plaza waiting areas.

Benches

Benches shall be a minimum of (6) six feet in length and to located outside the bus shelters. A minimum of (9) nine benches shall be provided and should be based on the transit/park and ride lot size and frequent use of the facility. Benches shall not be in the bus shelters. Benches shall be located or backed by landscape planter islands or retaining walls. They shall be in shaded areas near tree islands or planters.

Leaning Rails

Leaning rails shall be a minimum of (4) feet in length and located inside the bus shelters.

Blast Resistant Trash Receptacles

Blast Resistant trash receptacles are required at all transit and park and ride bus areas. Trash receptacles shall be blast resistant in accordance with recommendations from Homeland Security. A minimum of (2) two exterior grade waterproof trash receptacles shall be provided at the pedestrian bus plaza waiting area. The receptacles shall have lockable cover or access door. The receptacles shall be within (100) one-hundred feet from each other and shall not impede pedestrian traffic. They shall be located near the plaza entrance areas and be accessible for all users. Blast resistant trash receptacles shall not be located in the bus shelters.

Bicycle Racks and Bike Lockers

Bicycle racks should be provided at all park & ride facilities where demand exists. A minimum of (3) bike racks shall be provided. Refer to Section 4.6 for additional information. Bike lockers may be required based on bicycle user demand as well as site specific security concerns for the park & ride facility. All bike lockers shall be lockable, shatterproof, weatherproof, and provide visibility into locker contents for security and locker availability. All bike lockers shall meet homeland security requirements.

Bollards

Bollards shall be provided at the bus plaza area for pedestrian safety and security to help deter vehicles or terrorist attacks. The bollard height shall be a minimum (30) thirty inches in height. They should be arranged in a linear fashion in which the center of the bollards is parallel to the center line of existing streets. Bollard spacing shall be a minimum of (36) and (48) inches depending on the kind of traffic expected. The maximum spacing should be (6) six feet. Bollards shall be located at the sidewalk entrance locations of the bus plaza and at the bus loading area. Bollards shall be a minimum of (4) four feet from the back of curb. A minimum of two or three bollards shall be removable to allow vehicular access to the bus plaza platform for maintenance or emergency purposes.

Chain Link Fencing

Commercial grade black vinyl chain link fence shall be provided around the parking lot area or property line for security reasons. The posts shall be spaced (8) eight feet on center and at least (1) one lockable gate shall be provided to access behind the fence for maintenance purposes. Pedestrian sidewalk and or trail access near adjacent land uses shall be evaluated for potential connectivity at each park and ride site.

Informational Kiosk/Display Case

Informational kiosk/display case shall be double sided with tempered glass, lockable, and centrally located with the bus plaza area. The informational kiosk shall be used for containing transit map routes and pertinent information containing to the park and ride site and Express transit.

Traffic Signal Mast Arm, Light Pole, and Miscellaneous Signal Hardware

Decorative traffic signal mast arms and poles shall be provided if the local jurisdiction does not have a standard. This standard will only apply for areas that might warrant a new signal at an existing intersection or require a signal upgrade.

Bench

Landscape Forms

Model No: Stay Bench SA 477

(or approved equal)

Phone: 800.430.6209

Website: <http://www.landscapeforms.com>

Description:

- Backed with dividers and arms
- 23"d x 69"l x 32"h
- Color to coordinate with Architecture (Recommended Metallic Silver)
- Back and Seat perforated aluminum supported by aluminum extrusions
- Surface mounted or embedded
- Stainless steel hardware
- Install per manufacturers recommendations

Alternate Benches:

- Dumor, Bench 195 powder-coated steel, surface mount, dividers and arms
- Thomas Steel, Model No: Wingra 6' Bench, Perforated metal with end and intermediate arm rests, powder coated steel, storm metallic

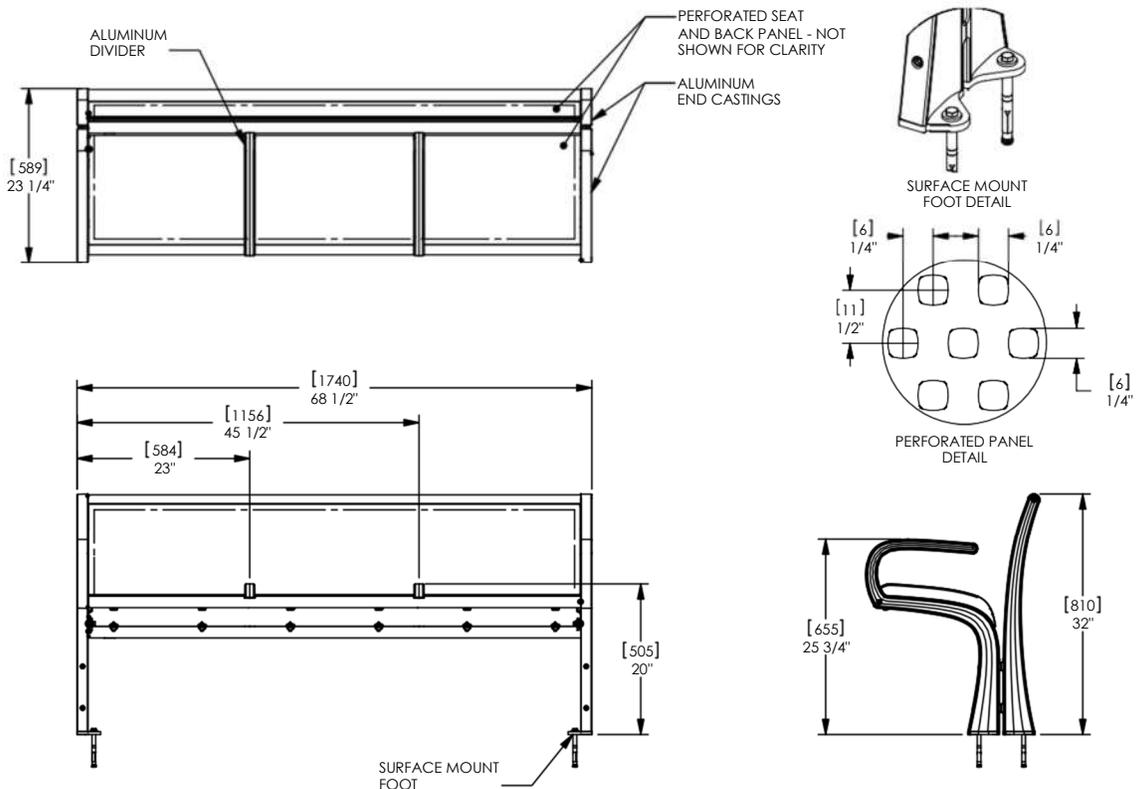

Leaning Rail

Landscape Forms

**Model No: Connect – Leaning Rail 30”
(or approved equal)**

Phone: 800.430.6209

Website: <http://www.landscapeforms.com>

Description:

- 6”d x 45”l x 30”h
- Color to coordinate with Architecture (Recommended Metallic Silver)
- Aluminum
- Surface mounted
- Stainless steel hardware
- Install per manufacturers recommendations

Alternate Leaning Rails:

- Keystone Ridge Designs, Inc., Model: Penn - 4’, surface mount
- Brasco International, Inc, Model No: Eclipse PERF – Leaning Rail

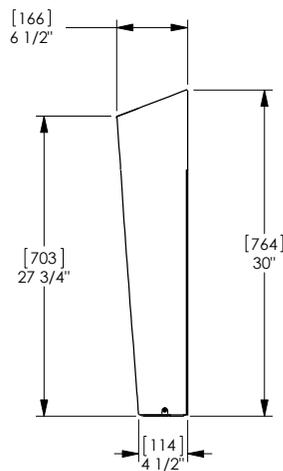
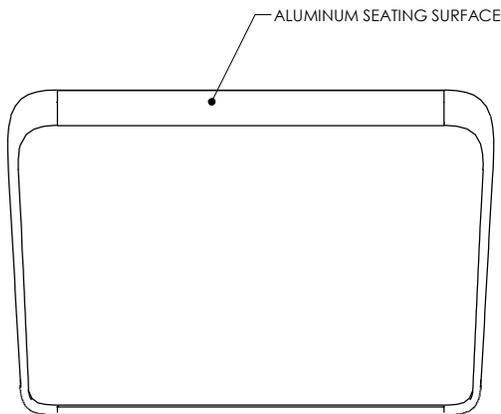
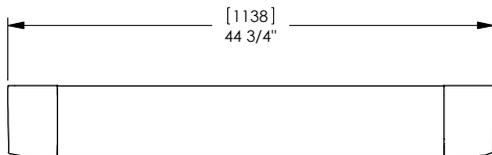

Bicycle Rack

Landscape Forms

Model No: Loop (or approved equal)

Phone: 800.430.6209

Website: <http://www.landscapeforms.com>

Description:

- 14" d x 36" l x 31" h
- Cast Aluminum
- Powder Coat color to coordinate with Architecture and other furnishings (Recommend Silver or Mercury)
- Place Bike Racks 30" apart (min.) and 24" from any wall (min.)
- Embedded mounting
- Install per manufacturers recommendations

Alternate Bike Racks:

- Victor Stanley, Model No: BRHS-101, steel, powder coated, surface mounted
- Brasco International, Model No: Aspen – Bike Rack, aluminum, powder coated, surface mounted

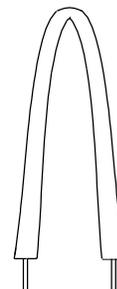
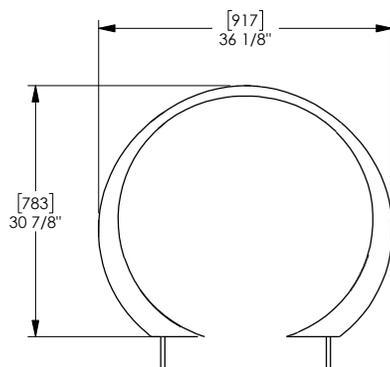
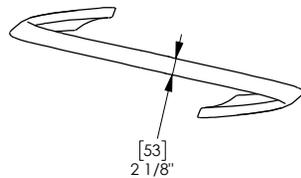

Blast Resistant Trash Receptacle

FFI Tactical (Energetics Technology Ltd.)
Model No: TC 95 Blast Resistant Litter Bin (or equivalent)
Phone: 727-490-3609 Ext. 111
Website: www.ffitactical.com
<http://www.energetics-technology.com>

Description:

- Perforated Stainless Steel
- Blast resistant per Homeland Security recommendations
- Install per manufacturers recommendations

Alternate Trash Receptacles:

- Trashcans Unlimited, LLC (Mistral Security), Model No: 40 Gallon Blast Resistant Trash Can Stainless Steel (Protection Level 3)
- NABCO, Model No: Blast Mitigating Trash Receptacle



The TC95 Blast Protected Litter Bin/Trash Can combines keeping the environment clean with protecting the public against terrorist explosives threats. Tested to the latest UK Home Office standards (2011), the TC95 is designed to protect against major blast threats and is suitable for most sensitive locations. The shell remains intact providing all-round horizontal protection whilst the lid disintegrates into harmless particles.

Maximum protection for busy public areas



Durable Construction

- Exceptional blast mitigation – meets HOSDB 7-star rating
- Easy to use for efficient everyday emptying
- Slick and durable design for busy environments
- Incorporates SABREMAT™ technology
- Superior all-round horizontal blast fragment protection
- Helps decrease vertical pressure
- Very low maintenance costs

- Large capacity, self-draining, easily cleaned
- Uses standard bin bags
- Bolt down mounting for extra safety
- Simple emptying procedure
- Blast disintegrating and fire-retardant GRP lid
- Highly robust and durable
- Recycling option available
- Available in a variety of finishes to customer specification

SPECIFICATIONS	
Total weight	
395 kg	871 lbs
Exterior dimensions	
Diameter	700 mm / 28"
Height	835 mm / 33 "
Interior dimensions	
Volume	95 liter / 21 gal



Bollard

Idealshield

ASTM k12 Crash Bollard and Decorative Sleeve - 10" PAWN DECORATIVE BOLLARD (Removable and Fixed)

Phone: 1.866.825.8659

Website: <http://www.idealshield.com>

Description:

- Bollard shall be ASTM k12 crash bollard (approved by the DOD and tested for a 16,500 lb. vehicle at 50 mph.
- A minimum of two or three bollards shall be removable (not fixed) to allow for vehicular access to the platform.
- Colors to coordinate with other site furnishings and architecture
- Install per manufacturers recommendations

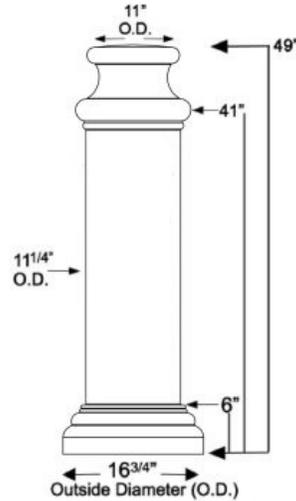

Steel Pipe ID = 10"
Steel Pipe OD = 10.75"
Ideal Sleeve ID = 10 7/8"

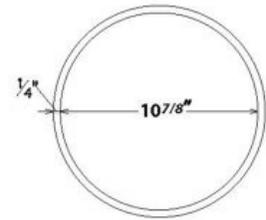

Cross Section of Sleeve

10" pipe up to 41" tall
8" pipe up to 41" tall
6" pipe up to 48" tall

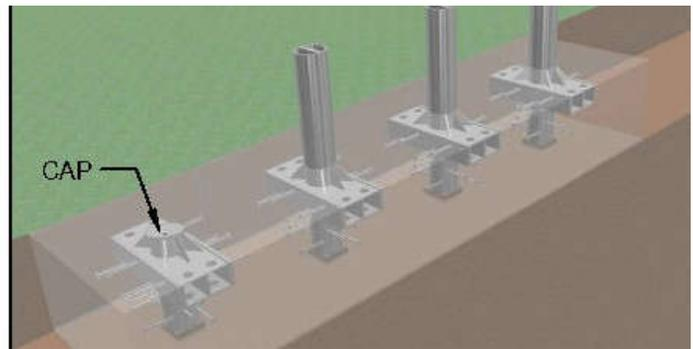
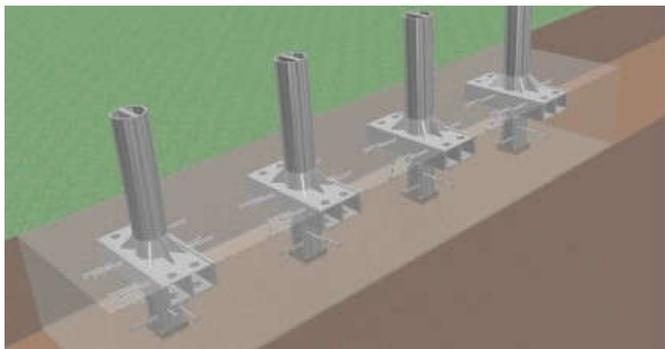

10

NOTE
RECOMMENDED BOLLARD SPACING
OF 60" O/C OR LESS.

TYPICAL BOLLARD ARRAY INSTALLATION

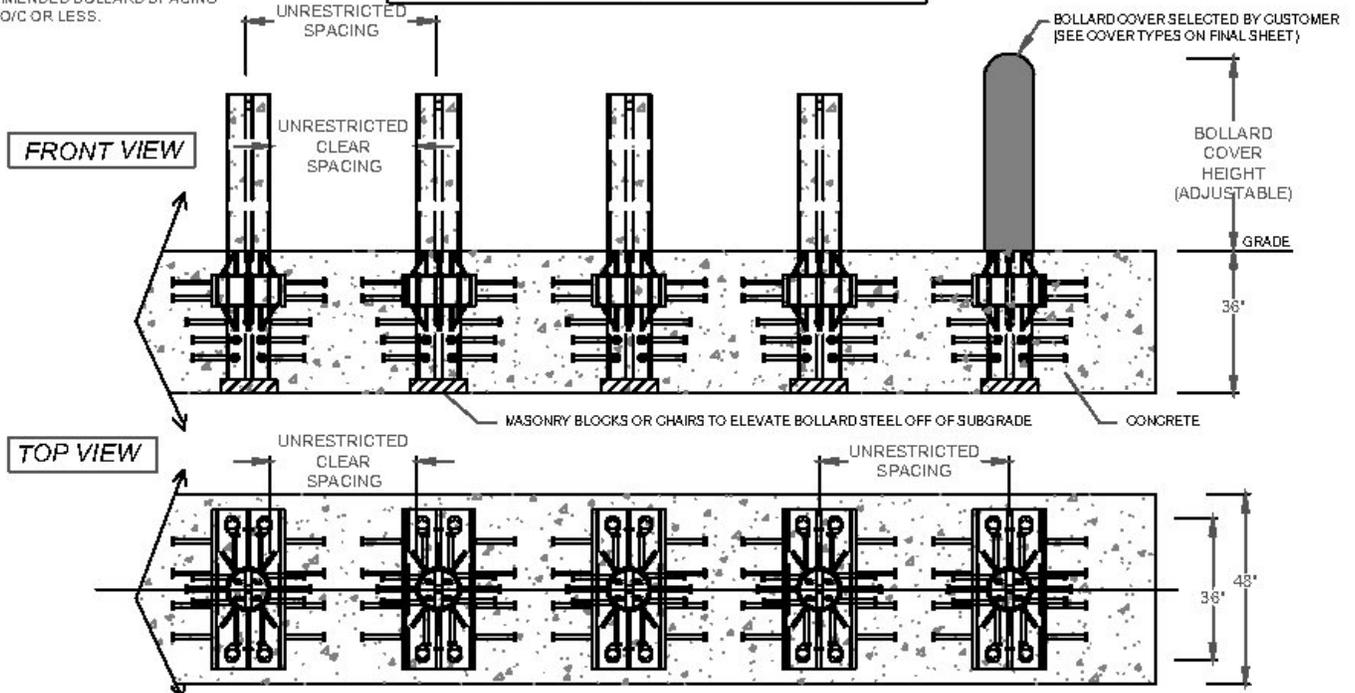

Informational Kiosk/Display Case

Brasco International
Model No: Eclipse PERF
(or equivalent)
Phone: 313.393.0393
Website: <http://www.brasco.com>

Description:

- Aluminum
- 6" depth, 80-inch Height, 64-inch Width
- Tempered Glass
- Tamper Resistant
- Stainless steel hardware
- Colors to coordinate with other site furnishings and architecture
- Internal LED illumination (Optional)
- Install per manufacturers recommendations

Alternate Display Case:

- Tolar Manufacturing, transit display, powder-coated, surface mounted
- LMG Lucid Mgmt Group, Advertising display/map case (City Line Standard)



SPECIFICATIONS	
Overall Depth	6 inches
Overall Height	80 inches
Overall Width	64 inches
Overall Media Size	48 inches x 69.50 inches
Viewable Media Area	45.875 inches x 67.125 inches
Columns	Aluminum 4.5 inches round, 1/4 inch thick
Finish	Standard Power Coat, Anti-Graffiti Powder Coat
Anchoring	Surface mounted or in-ground mounted to concrete with adjustable anchor boots
Options	Escutcheon covers, AC powered 28W LED Illumination
Glazing	Tempered Glass
Hardware	Stainless Steel, Tamper Resistant, Tool Included
Door Access	Side Swinging Stainless Steel Piano Hinge
Media Attachment	Magnetic Strips. Holds up to 12mil Thickness at 3.5 lbs.

Ordering matrix: AB-EC-AC (AC illuminated), AB-EC-DC (DC illuminated), AB-EC-UL (Unlit)

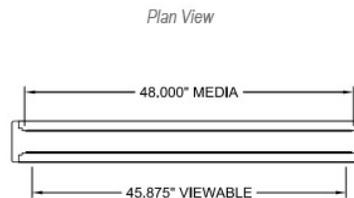
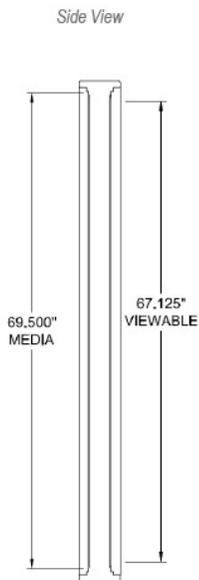
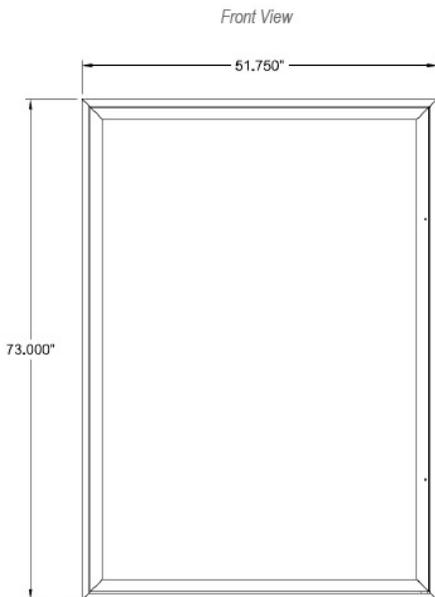

Chain Link Fence

Master Halco

Model No: Perafused II - Polyolefin Coated Chain Link Fence and Gate (or equivalent)

Phone: 404.766.0063

Website: <http://www.masterhalco.com>

Description:

- Commercial grade black vinyl chain link fence and gate (SS 40 Pipe)
- 3 Rails (Top, Middle, and Bottom)
- Refer to GDOT Standard Details and specifications.
- Install per manufacturer's recommendations

Alternate Chain Link Fence Manufacturer:

- Circle A Fence, 770.424.7862, same as specified above



FENCE HEIGHT	END & CORNER POSTS		LINE POSTS	
	NOMINAL HEIGHT	B-1 BAR LENGTH	H-1 HEIGHT ABOVE GRADE	B-2 BAR LENGTH
8'-0" [2438MM]	11'-0" [3353MM]	8'-0 5/8" [2454MM]	10'-8" [3251MM]	7'-8 7/8" [2359MM]

10

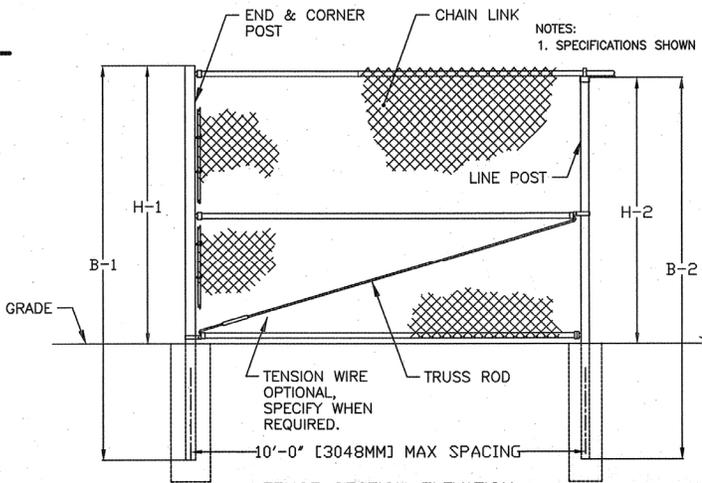

FENCE SECTION ELEVATION WITH TOP RAIL & BOTTOM RAIL

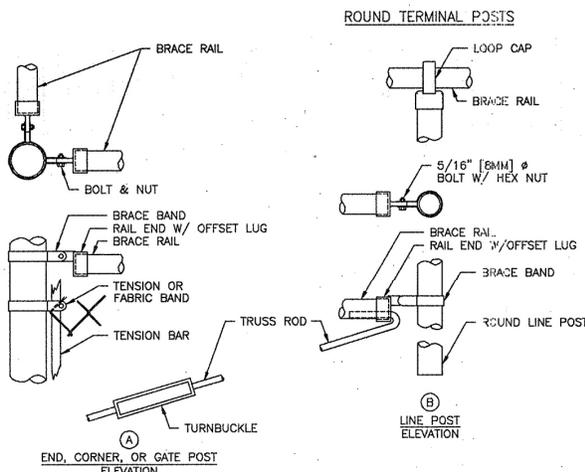

- NOTES:
1. METRIC DIMENSIONS ARE NOMINAL EQUIVALENTS TO U.S. DIMENSIONS.
 2. SPECIFICATIONS SHOWN CAN BE CHANGED BY MASTER HALCO ONLY.
 3. ALL MATERIAL TO CONFORM TO FEDERAL SPEC. 93-1-1916 (1-22-74).
 4. ALL GALVANIZED FITTINGS TO CONFORM TO ASTM A153.
 5. THIS DWG CORRESPONDS WITH DWGS 1-1110, --1120, 1-1130 & 1-1140.

SINGLE OR DOUBLE LEAF GATES			
NOM HEIGHT (H)	UPRIGHT HT (U)	FRAME HT (F)	
WITHOUT BARBED WIRE		ACTUAL DIM	ACTUAL DIM
8'-0" [2438MM]	7'-10" [2388MM]	7'-8 1/2" [2350MM]	

SINGLE LEAF GATES			
OPENING	GATE POSTS	HINGE SPACE (S)	
FACE TO FACE	SQ & RND SIZES	POST TO UPRIGHT	
3'-0" [914MM]	2 1/2" [63.5MM] SQ	FOR SQUARE & ROUND GATE POSTS:	
6'-0" [1829MM]	2.875" [73MM] OD	2 1/4" [57MM]	

TYPICAL SINGLE SWING GATE ROUND END POSTS

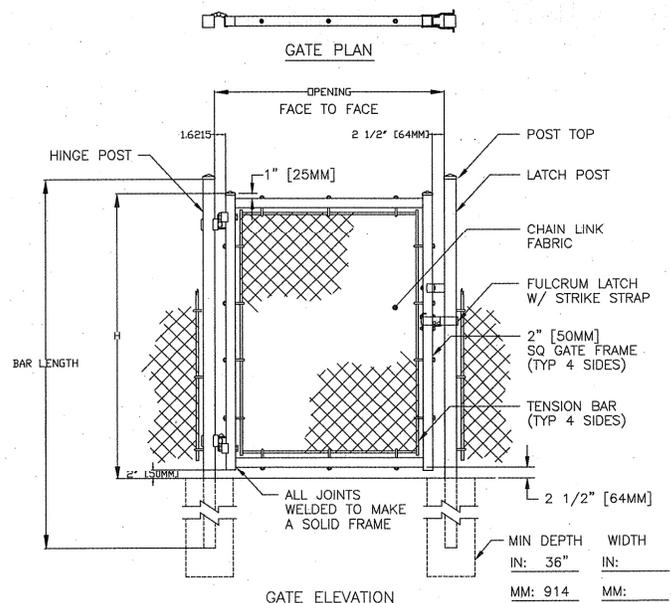

- NOTES:
1. METRIC DIMENSIONS ARE NOMINAL EQUIVALENTS TO U.S. DIMENSIONS.
 2. SPECIFICATIONS SHOWN CAN BE CHANGED BY MASTER HALCO ONLY.
 3. FOOTING WIDTH TO BE (4)X POST WIDTH.
 4. GATES MAY BE MANUALLY OR ELECTRICALLY OPERATED. HARDWARE WILL VARY FOR ELECTRICALLY OPERATED GATES.
 5. CENTER UPRIGHT REQUIRED ON GATE LEAVES 8'-0" (2438MM) & WIDER.

Traffic Signal Mast Arm, Light Pole, and Miscellaneous Signal Hardware

Valmont Industries, Inc.

Model No. Smooth Pole with Huntington Decorative Base Cover - Cast Aluminum Clamshell

or

Union Metal

Model No. Smooth Pole with Columbian Decorative Base Cover or equivalent

Description:

- Smooth pole ornamental base and pole top, round steel pole/shaft and curved arm.
- Black powder coat finishes all equipment including but not limited to signal heads, pedestrian signal heads, pushbuttons, video detection cameras and CCTV cameras.
- Install per manufacturer's recommendations
- This standard should only be used if there is no local jurisdiction requirement.
- All products need verification of Buy America Requirement



POLE BASE DIAMETER RANGE		DIMENSIONS OF BASE COVER		MODEL NUMBER
TAPERED SMOOTH OR FLUTED STEEL & FLUTED ALUMINUM (IN)	ALUMINUM NON-TAPERED SMOOTH (IN)	DIA (IN)	HEIGHT (IN)	
7.0 - 10.0	7.0 - 10.0	24.0	35.5	3L01EC
10.1 - 13.0	10.0 & 12.0	28.4	40.4	3L02EC
13.1 - 17.0	-	33.0	44.0	3L03EC

Roundabout Apron Detail

Pavestone

Model No: Vehicular Paver 80 MM min.

Phone: 770.306.9691

Website: <http://www.pavestone.com>

Description:

- Pavestone pavers (80 MM) min, thickness Vehicular
- Color: Refer to Section 13 for Approved Color Palettes
- Pattern: 45-degree herringbone.
- 6 Inch width concrete banding/curb.
- Install per detail and notes and manufacturer recommendations

Approved Manufacturers:

- Pavestone**
- Belgard**
- Hanover**
- Pine Hall Brick, Inc.**

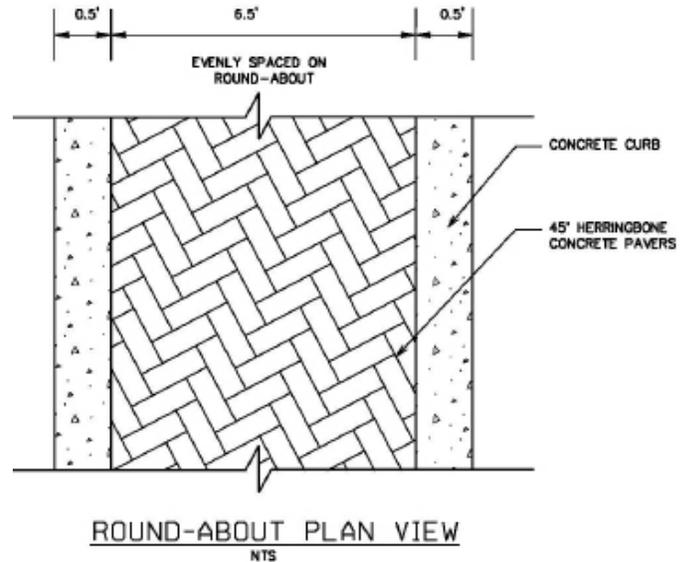

10

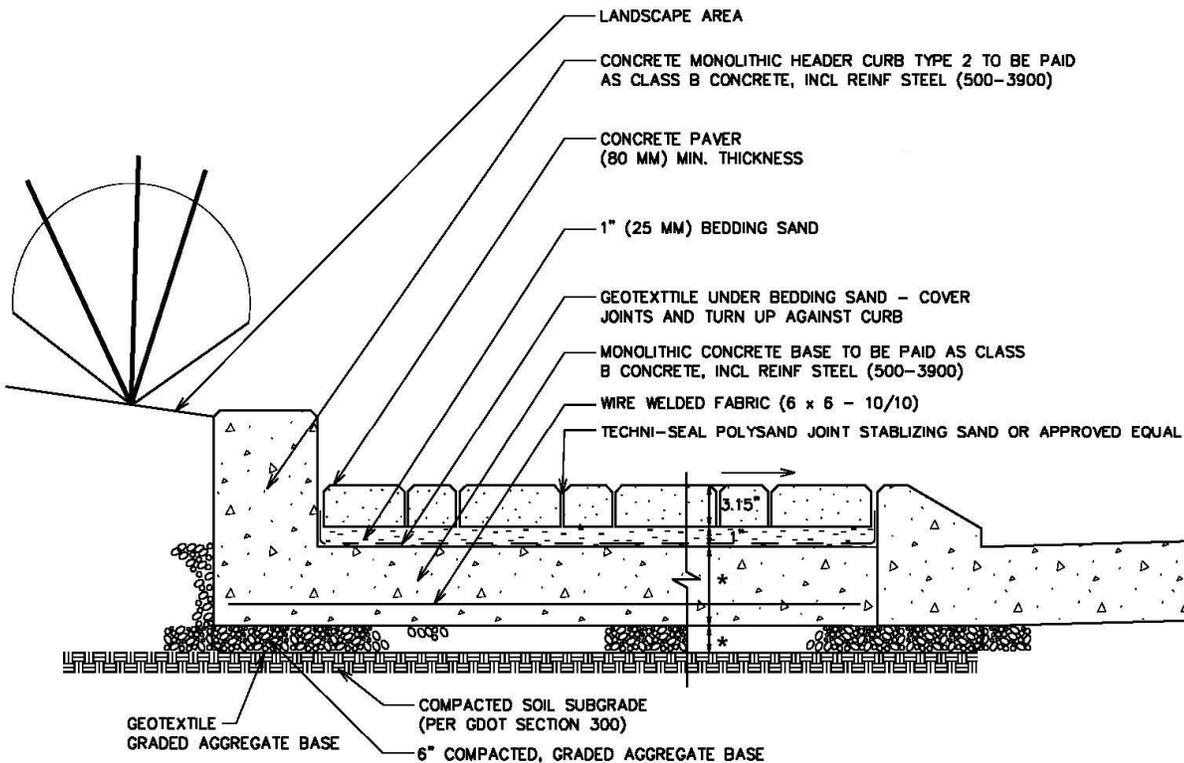

* THE PAVEMENT SECTIONS AND THICKNESSES MAY VARY BASED ON GEOTECHNICAL RECOMMENDATIONS. A GEOTECHNICAL ENGINEER SHALL EVALUATE EACH SITE AND THE EXISTING SOIL CONDITIONS. THE GEOTECHNICAL ENGINEER'S RECOMMENDATIONS MAY OVERRIDE THE TYPICAL PAVEMENT SECTION

NOTE: CONCRETE PAVERS TO BE INSTALLED FLUSH WITH ADJACENT CURBING, EXCEPT AS DIRECTED BY ENGINEER TO SMOOTH OUT IRREGULARITIES.

ROUND-ABOUT APRON ON CONCRETE BASE

NTS

Specialty Unit Concrete Pavers

Pavestone or equivalent

Model No: City Stone Series (Tumbled style, 80 MM,

Phone: 770.306.9691

Website: <http://www.pavestone.com>

Description:

- Refer to Section 13 for Approved Color Palettes
- Install per manufacturer recommendations

Approved Manufacturers:

**Pavestone
Belgard
Hanover**



10

PRODUCT INFORMATION

City Stone™ Series is available in seven (7) sizes. Height/Thickness 2 3/8" = 60mm and 3 1/8" = 80mm.

City Stone™ I

Nominal Dimensions	5 13/16" W x 11 3/4" L	
	148mm x 298mm	
Height/Thickness:	60mm = 2 3/8" 80mm = 3 1/8"	
Stones/Sq.Ft.	2.08 2.08	
Wt./Stone	14 lbs. 18 lbs.	
Stones/Pallet	200 160	
Approx. Wt./Pallet	2,888 lbs. 2,880 lbs.	
Sq. Ft./Pallet	96 78	
Product Number	287 289	

Symetry™ Square Only*

Nominal Dimensions	5 13/16" W x 5 13/16" L	
	148mm x 148mm	
Height/Thickness:	60mm = 2 3/8"	
Stones/Sq.Ft.	4.16	
Wt./Stone	6.7 lbs.	
Stones/Pallet	400	
Approx. Wt./Pallet	2,688 lbs.	
Sq. Ft./Pallet	96	
Product Number	666	

*Coordinates with City Stone™ Series

City Stone™ II

1/2 Square & Square Bundled Together

Nominal Dimensions		
1/2 SQ:	5 13/16" W x 2 7/8" L	
	148mm x 73mm	
SQ:	5 13/16" W x 5 13/16" L	
	148mm x 148mm	
Height/Thickness:	60mm = 2 3/8"	
Stones/Sq.Ft.	8.42 4.12	
Wt./Stone	3.5 lbs. 1/2 SQ. 6.7 lbs. SQ.	
Stones/Pallet	240 1/2 SQ. 320 SQ.	
Approx. Wt./Pallet	2,968 lbs.	
Sq. Ft./Pallet	106	
Product Number	296	

City Stone™ II Rectangle Only

Nominal Dimensions:	5 13/16" W x 8 3/4" L	
	148mm x 223mm	
Height/Thickness:	60mm = 2 3/8" 80mm = 3 1/8"	
Stones/Sq.Ft.	2.659 2.666	
Wt./Stone	11.2 lbs. 13.5 lbs.	
Stones/Pallet	250 200	
Approx. Wt./Pallet	2,520 lbs. 2,700	
Sq. Ft./Pallet	90 75	
Product Number	297 298	

City Stone™ II Parkway™

1/2 Square & Square Bundled Together

Nominal Dimensions		
1/2 SQ:	5 13/16" W x 2 7/8" L	
	148mm x 73mm	
SQ:	5 13/16" W x 5 13/16" L	
	148mm x 148mm	
Height/Thickness:	60mm = 2 3/8"	
Stones/Sq.Ft.	8.42 4.12	
Wt./Stone	3.5 lbs. 1/2 SQ. 6.7 lbs. SQ.	
Stones/Pallet	240 1/2 SQ. 320 SQ.	
Approx. Wt./Pallet	2,968 lbs.	
Sq. Ft./Pallet	106	
Product Number	291	

City Stone™ II Parkway™ Rec Only

Nominal Dimensions:	5 13/16" W x 8 3/4" L	
	148mm x 223mm	
Height/Thickness:	60mm = 2 3/8"	
Stones/Sq.Ft.	2.659	
Wt./Stone	11.2 lbs.	
Stones/Pallet	250	
Approx. Wt./Pallet	2,520 lbs.	
Sq. Ft./Pallet	90	
Product Number	292	

***City Stone™ III**

Nominal Dimensions:	11 7/8" W x 11 3/4" L	
	298mm x 298mm	
Height/Thickness:	60mm = 2 3/8" 80mm = 3 1/8"	
Stones/Sq.Ft.	1 1	
Wt./Stone	27 lbs. 36 lbs.	
Stones/Pallet	120 80	
Approx. Wt./Pallet	3,360 lbs. 3,456 lbs.	
Sq. Ft./Pallet	120 96	
Product Number	277 279	

City Stone™ IV

(also see Holland Stone IV)

Nominal Dimensions:	3 7/8" W x 3 7/8" L	
	98mm x 98mm	
Height/Thickness:	60mm = 2 3/8"	
Stones/Sq.Ft.	9.32	
Wt./Stone	3 lbs.	
Stones/Pallet	960	
Approx. Wt./Pallet	2,884 lbs.	
Sq. Ft./Pallet	103	
Product Number	213	

*Not recommended for tumbled or urban traffic. City Stone III™ does not conform with ASTM C-836 size and impact noise requirements.

*Fractional dimensions are nominal.

City Stone™ V

Nominal Dimensions:	7 13/16" W x 7 13/16" L	
	198mm x 198mm	
Height/Thickness:	60mm = 2 3/8" 80mm = 3 1/8"	
Stones/Sq.Ft.	2.53 2.3	
Wt./Stone	12 lbs. 15.6 lbs.	
Stones/Pallet	340 192	
Approx. Wt./Pallet	2,884 lbs. 2,988 lbs.	
Sq. Ft./Pallet	103 83	
Product Number	257 259	

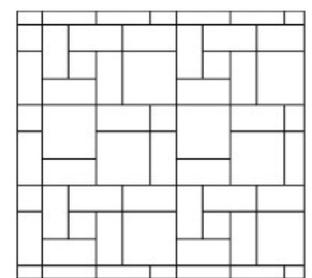
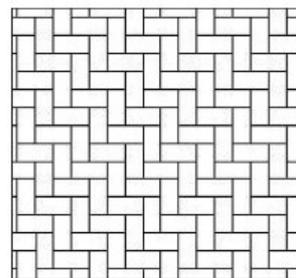
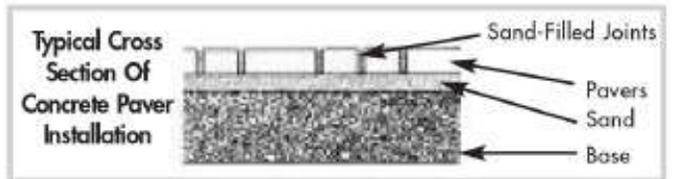

Specialty Unit Permeable and Detectable Warning Concrete Pavers

Pavestone or equivalent
Model No: Concrete Permeable Paver Eco Piora
Phone: 770.306.9691
Website: <http://www.pavestone.com>

Concrete Detectable Warning Paver Hanover Architectural Products or equivalent
Detectable Warning Paver (Size 24"x24")

Description:

- Refer to Section 13 for Approved Color Palettes
- Install per manufacturer recommendations

Approved Manufacturers:

Pavestone
Belgard
Hanover

10

Stocked Sizes	Stocked Colors
11 3/4" x 11 3/4" x 2" (297mm x 297mm x 51mm)	Red 15
23 1/2" x 23 1/2" x 2" (597mm x 597mm x 51mm)	Charcoal
	Yellow (M1517)

Please Note: Other sizes and colors are available upon request when quantities permit. Contact a Hanover® Representative for more information.

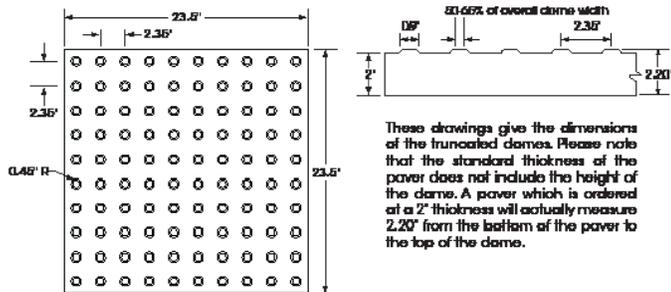

Detectable Warning Paver

PRODUCT INFORMATION
Eco-Piora is available in one size. Height = 80mm



Eco-Piora
 Dimensions: 4 1/4" W x 9 7/8" L x 3 1/8" H
 Wt./Stone: 11.5 lbs.
 Stones/Pallet: 280
 Approx. Wt./Pallet: 3,255 lbs.
 Sq. Ft./Pallet: 68
 Product Number: 699

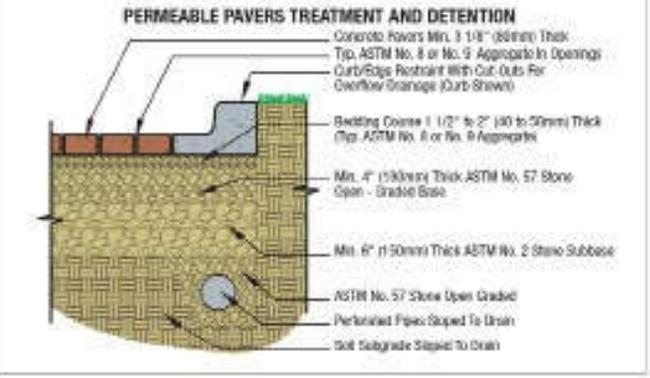
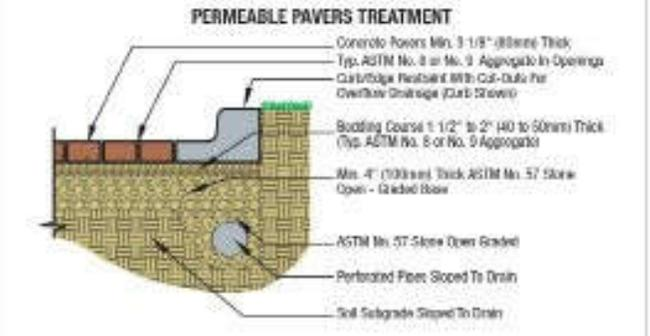

Eco Piora Permeable Paver

Clay Unit Paver

Pine Hall Brick or equivalent

Beveled Edge Pavers (English Edge Series)

Pedestrian Traffic Size: 2-1/4" x 4" x 8"

Vehicular Traffic Size: 2-3/4" x 4" x 8"

Clay Permeable Paver:

Pine Hall Brick or equivalent

StormPave (ADA compliant)

Acceptable paving pattern for vehicular traffic: Herringbone pattern oriented at 45 degrees or 90 degrees to the direction of traffic.

Acceptable paving pattern for pedestrian traffic: Running Bond, Basketweave and Herringbone

Description:

- Refer to Section 13 for Approved Color Palettes
- Install per manufacturer recommendations

Natural Stone Pavers

Granite Pavers

Consistent dimensional sized granite cobblestones.

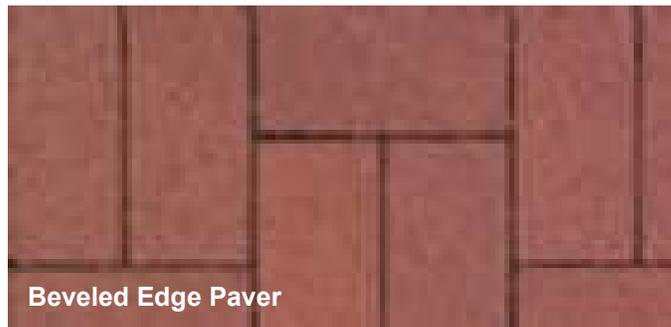

Beveled Edge Paver



StormPave Permeable Paver



45 Degree Herringbone Installation Pattern

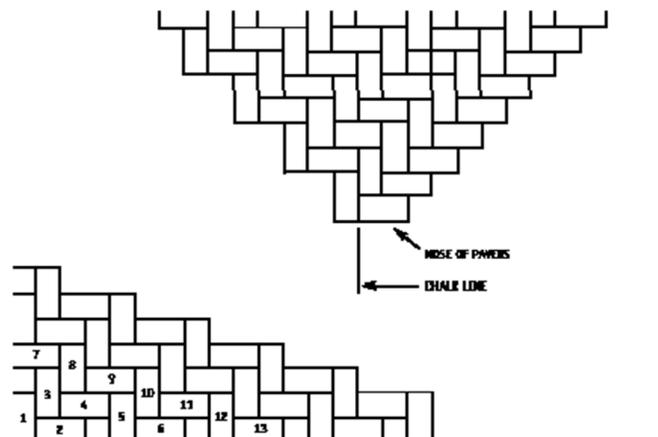

90 Degree Herringbone Installation Pattern

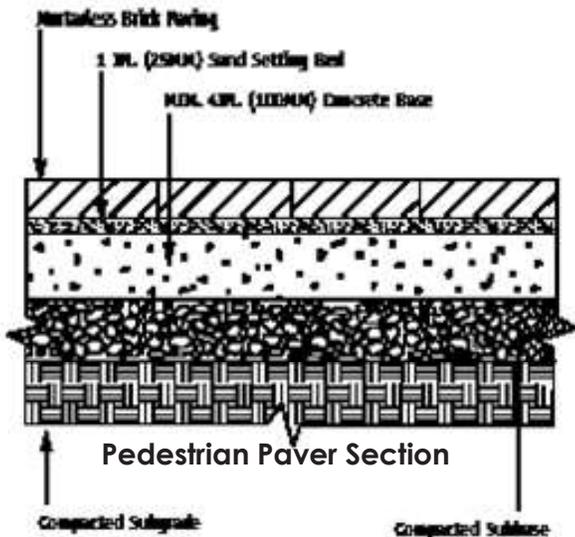

Pedestrian Paver Section



Running Bond

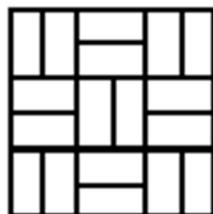

Basketweave



PERMEABLE PAVEMENT CROSS SECTION

THIS PAGE IS INTENTIONALLY LEFT BLANK

11

Site Lighting & Emergency Call Box Requirements



11. Lighting Requirements

11.1. Introduction

Good outdoor lighting serves several uses by increasing safety and enhancing the nighttime use and character for each park & ride facility. However, improperly designed and/or installed lighting can create problems of excessive glare, light trespass, decreased safety and higher energy use. These guidelines are established to define appropriate lighting characteristics. Luminaries should be consistent within the development and along the proposed road/driveway corridors and parking lot.

Luminaries should be placed at an appropriate distance to achieve the desired illumination levels determined by a qualified electric engineer or other lighting design professional. Mounting heights vary depending on final pole spacing to meet the required illumination levels. The type of light sources to be used for any exterior lighting shall meet all approved regulations. The purpose is to provide clarity for vehicular and pedestrian movement without needlessly lighting adjacent properties and development.

11.2. Lighting Design Criteria

1. Exterior and special lighting may include decorative luminaries for seasonal use and spot lighting for special features. It may also include string lighting in trees or up-lighting of signs, trees, and buildings. All exterior luminaries shall be rated for wet locations and of the cut-off type. Luminaries shall include shields to protect passing vehicles and pedestrians from glare and not impede their views. Suspended cable lights may be used for down lighting pedestrian passages, open structures and other exterior locations.
2. Collector Road lighting is planned to be located in the median when present and/or on the shoulder of the roadway per local code requirements. Typically, streetlights are placed within the right-of-way and a qualified engineer will determine the spacing. Only replace existing lighting on roadways that are required due to construction activities.
3. Lighting shall be designed to control glare, minimize light trespass onto adjacent properties, minimize direct upward light emission, promote effective security, and avoid interference with safe operation of motor vehicles. The minimum intensity needed for the intended purpose shall be used. This paragraph is not intended to preclude the use of decorative lantern fixtures with visible lamps.
4. All parking areas, walkways, vehicle entrances and service/loading areas shall provide area lighting enough to achieve an average maintained illumination level as recommended by the IES Lighting Handbook, measured at grade or ground level.
5. Luminaries in parking areas shall be located to assure adequate light levels without displacing planned trees. Luminaire placement shall be shown on landscape plans.
6. Light pole height, style, design shall be compatible with the building design and shall consider safety, function and aesthetics. Light poles installed along sidewalks shall be pedestrian scale and shall not exceed fourteen (14) feet.
7. Luminaries may be used to illuminate buildings, landscaped medians/islands and grounds for safety purposes and to enhance appearance. The visual effects of such lighting shall be subtle.
8. Luminaries attached to building exteriors or mounted on the ground to reflect upon building exteriors shall be consistent with the architectural style of the building.
9. Luminaries of logos should be compatible with the primary building and respect adjacent buildings. Bright and intense lighting is strongly discouraged.
10. Blinking, moving or changing intensity of illumination signs are prohibited.
11. Security lighting shall be shielded and shall focus on the side or rear entry door.
12. Specialty lighting, up lighting, or low-level lighting shall only be used on entry monument signage and bus loading areas.
13. All parking area lighting will be full cut-off type fixtures.
14. All building lighting for security or aesthetics will be full cut-off or a shielded type, not allowing any upward distribution of light. Floodlighting is discouraged, and if used,

must be shielded to prevent:

- Disability glare for drivers or pedestrians,
 - Light trespass beyond the property line, and
 - Light above a 90-degree, horizontal plane.
15. Adjacent to residential property, no direct light source will be visible at the property line at ground level or above.
 16. LED lights are required for all types of lighting sources preferably remotely controlled and with photocells.
 17. Lighting plan shall be coordinated with landscape planting plan for light pole, conduit, wire, and utility box locations.

11.3. Engineering Requirements for LED's Lighting System

Use luminaries that are complete, including but not limited to driver, LEDs, surge protection device (SPD), associated hardware and wiring. Must be equipped with: – an isolated power supply output – a power supply that has overheat protection – a power supply that is self-limited short circuit protected and over load protected – a power supply that is terminated with quick disconnect wire harnesses for easy maintenance. Wire nut termination is not acceptable. The entire system shall include at a minimum the following:

Site Lighting LED Heads/Receptacles / Luminaries

1. Listed and labeled in accordance with the U.S. Department of Energy Lighting Facts Program: <https://www.lightingfacts.com/Products>.
2. Mountable high above ground attached to existing poles.
3. NEMA standards compliant (weatherized to sustain multi directional water spray, dust, snow, freezing & hot temperature...) Designed to allow water shedding.
4. UNIVERSAL: Capable of receiving at its top a 7-PIN Smart Node with NEMA standard ANSI C136.41-2013 Twist-Lock connector
5. With LEDs capable of emitting Color Temperature: 4000K (3710-4260K), Color Rendering Index (CRI): greater than or equal to 60.

6. With LEDs dimmable at least from 0 to 10 increments
7. All hardware on the exterior of the housing including cover and latch to be stainless steel, zinc or steel with zinc alloy electroplate and chromate top coat
8. Ensure roadway luminaries are easy to open when properly mounted or when sitting on its top side when placed on the ground without the use of tools. Ensure underpass luminaries are vandal-proof.
9. Have readily accessible internal parts.
10. Ensure the total weight of luminaire(s) and accessories do not exceed the load capacity of the pole and arm.
11. Provide luminaries with a flat area on the top of the housing to allow a level to be used for proper orientation of the Luminaire, or supply luminaries with an integral bubble level.
12. Electronic components capable of fully operating in a temperature range -40°C to +50°C (-40° F to 122°F).
13. Provide lumen output enough to meet the lighting design from the photometric study.
14. Have housing with a life rating on all electrical components of 100,000 hours or greater when operating at a continuous 25°C ambient. LEDs have a minimum rated life of 70,000 hours when operated at 25° C (77° F). Deliver an average 80% of initial delivered lumens after 100,000 hours of operation when operated at 25°C.
15. Equipped with a UL-labeled, 3-wire surge protective device (SPD) that provides common and differential mode protection and an inductive filter circuit that reduces the amount of energy passed through to the electronics during a surge event. SPD to be thermally fused and have failure mode such that luminaire is off if SPD fails. SPD to provide IEEE/ANSI C62.41 Category C (10kV/5kA) level of protection for the entire luminaire.
16. No more than a 15% reduction in LED's lumen output due to the operating temperature of the luminaire, compared to the LED's lumen output when it is operating at 25°C.
17. The light distribution pattern at the road surface is to have an evenly dispersed appearance.

Wireless Outdoor Lighting Controller (Smart Node):

1. Nonproprietary [preferred but may consider equal or better] component of intelligent networked control system.
2. Mountable on top of the LED Head/ Receptacle.
3. With the needed number of PIN per the functions provided in the previous requirements.
4. Includes an integral GPS receiver [preferred]
5. Compatible with most lamp types, including LED, eHID, plasma, and induction
6. Power metering calibrated to 1% accuracy
7. Secure AES 128-bit encryption
8. High end trim for enhanced energy savings
9. Mountable to a NEMA standard ANSI C136.41-2013 Twist-Lock connector

Base Station or Gateway:

1. Part of the smart/intelligent control network.
2. Connects the wireless luminaire controllers with a central management system through cellular (through a 3G or LTE integrated modem) network initially, then convertible to LAN or Fiber connection in the not too far future (~ 3 years).
3. Capable of supporting at least 2000 controller nodes up to 6 km line of sight.
4. Housed in a least an IP66 rated, NEMA 4x enclosure that can be pole- or wall-mounted.
5. Includes lighting protected port, either affixed directly to the gateway or remotely mounted.
6. Capable of securing AES 128-bit encryption for wireless data transmission
7. Includes an external RF port for extended coax antenna runs
8. Includes a built-in lighting surge arrester on all antenna ports
9. Capable of working in extended temperature range conditions without service interruptions.

Outdoor Motion Sensor:

1. Pole or wall mountable
2. Capable of working with controller nodes or gateway
3. Capable of working in outdoor wet locations
4. Includes at least a 270-degree field of view for PIR detection

Parking Lot Light

Lithonia Lighting

Model No: D-Series Size 1 LED Area Luminaire (or equivalent)

Phone: 800.279.8041

Website: <http://www.lithonia.com>

Description:

- Round Tapered Pole Mounting
- Black powder coat finish
- Install per manufacturer's recommendations



D-Series Size 1 LED Area Luminaire



Specifications

- EPA: 1.01 ft² (0.09 m²)
- Length: 33" (83.8 cm)
- Width: 13" (33.0 cm)
- Height: 7-1/2" (19.0 cm)
- Weight (max): 27 lbs (12.2kg)

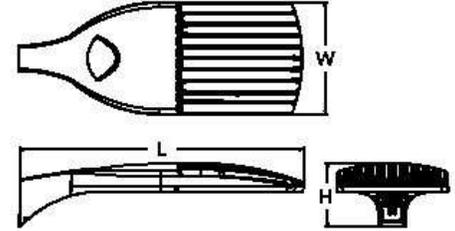

Capable Luminaire

This item is an A+ capable luminaire, which has been designed and tested to provide consistent color appearance and system-level interoperability.

- All configurations of this luminaire meet the Acuity Brands' specification for chromatic consistency
- This luminaire is A+ Certified when ordered with DTL[®] controls marked by a shaded background. DTL DLL equipped luminaires meet the A+ specification for luminaire to photocontrol interoperability¹
- This luminaire is part of an A+ Certified solution for ROAM[®] or XPoint[™] Wireless control networks, providing out-of-the-box control compatibility with simple commissioning, when ordered with drivers and control options marked by a shaded background¹

To learn more about A+, visit www.acuitybrands.com/aplus.

1. See ordering tree for details.
2. A+ Certified Solutions for ROAM require the order of one ROAM node per luminaire. Sold Separately: [Link to Roam](#); [Link to DTL DLL](#).

Ordering Information

EXAMPLE: DSX1 LED P7 40K T3M MVOLT SPA DDBXD

Series	LEDs	Color temperature	Distribution	Voltage	Mounting	
DSX1 LED	Forward optics P1 P4 P7 P2 P5 P8 P3 P6 P9 Rotated optics P10 ¹ P12 ¹ P11 ¹ P13 ¹	30K 3000 K 40K 4000 K 50K 5000 K AMBPC Amber phosphor converted ²	T1S Type I short T2S Type II short T2M Type II medium T3S Type III short T3M Type III medium T4M Type IV medium TFTM Forward throw medium TSVS Type V very short	T5S Type V short T5M Type V medium T5W Type V wide BLC Backlight control ^{2,5} ECCO Left corner cutoff ^{2,5} RCCO Right corner cutoff ^{2,5}	MVOLT ^{2,4} 120 ³ 208 ^{2,4} 240 ^{2,4} 277 ³ 347 ^{2,4,7} 480 ^{2,4,7}	Shipped included SPA Square pole mounting RPA Round pole mounting WBA Wall bracket SPUMBA Square pole universal mounting adaptor ² RPUMBA Round pole universal mounting adaptor ² Shipped separately KMA8 DDBXD U Mast arm mounting bracket adaptor (specify finish) ¹

Control options	Other options	Finish required
Shipped installed NITAIR2 nLight AIR generation 2 enabled ⁸ PER NEMA twist-lock receptacle only (controls ordered separate) ¹¹ PER5 five-wire receptacle only (controls ordered separate) ^{11,12} PER7 seven-wire receptacle only (controls ordered separate) ^{11,12} DMG 0-10V dimming extend out back of housing for external control (leads exit fixture) DS Dual switching ^{13,14} PIR Bi-level, motion/ambient sensor, 8-15' mounting height, ambient sensor enabled at 5ft ^{15,16} PIRH Bi-level, motion/ambient sensor, 15-30' mounting height, ambient sensor enabled at 5ft ^{15,16} PIRHN Network, Bi-level, motion/ambient sensor ¹⁶ PIR1FC3V Bi-level, motion/ambient sensor, 8-15' mounting height, ambient sensor enabled at 5ft ^{15,16}	PIRH1FC3V Bi-level, motion/ambient sensor, 15-30' mounting height, ambient sensor enabled at 5ft ^{15,16} BL30 Bi-level switched dimming, 30% ^{17,18} BL50 Bi-level switched dimming, 50% ^{17,18} PNM1TDD3 Part night, dim till dawn ¹⁹ PNM1TSD3 Part night, dim 5 hrs ¹⁹ PNM1T6D3 Part night, dim 6 hrs ¹⁹ PNM1T7D3 Part night, dim 7 hrs ¹⁹ FAO Field adjustable output ⁸ Shipped installed HS House-side shield ²¹ SF Single fuse (120, 277, 347V) ⁴ DF Double fuse (208, 240, 480V) ⁴ L90 Left rotated optics ¹ R90 Right rotated optics ¹ Shipped separately BS Bird spikes ²² EGS External glare shield ²³	DDBXD Dark bronze DBLXD Black DNAXD Natural aluminum DWHXD White DDBTXD Textured dark bronze DBLTXD Textured black DNATXD Textured natural aluminum DWHTXD Textured white

Ordering Information

Accessories

Ordered and shipped separately.

DLL127T L51V	Bracket - SS (west-lock 120-277V)**
DLL37T L5CULV	Bracket - SS (west-lock 347V)**
DL480T L5CULV	Bracket - SS (west-lock 480V)**
DSH0T514 V	Shoring cap**
DSX1 H5 30C V	Houseside held for 30 LED unit*
DSX1 H5 40C V	Houseside held for 40 LED unit*
DSX1 H5 60C V	Houseside held for 60 LED unit*
PWMBA D01X D V*	Square and round pole universal mounting bracket (specify finish)**
MA8 D01X D V	Rectangular mounting bracket adapter (specify finish)**

For more control options, visit [D-FIT](#) and [SDAM](#) online.

NOTES

- P10, P11, P12 or P13 and round poles (190, 190) only available together.
- AMBPC is not available with BIC, ICCO, ICCO or R, P7, P8, P9 or P13.
- Not available with HS.
- MWOIT does not operate on any line voltage from 120-277V (50/60 Hz).
- Any P16 with BL30, BL50 or PNM1, is not available with 208V, 347V, 480V or MWOIT. It is only available in 120V or 277V specified.
- Single phase SP requires 120V, 277V or 347V. Double phase (DP) requires 208V, 240V or 480V.
- Not available with P1 or P10. Not available with BL30, BL50 or PNM1 options.
- Existing drilled hole only. Available as a separate component accessory, for retrofit use only. P11MBA (finish) U, 1 S G w/ carbon load rating per ANSI C136.31.
- Must order fixture with SFA option. Must be ordered as a separate accessory, see Accessories information. For use with 2-3/8" max arm (not included).
- Must be ordered with PRRN.
- Precooled and shipped as a separate line item from Acuity Brackets Controls. See accessories. Not available with DS option. Skinning not included.
- If RCAMP code required, it must be ordered and shipped as a separate line item from Acuity Brackets Controls. Not available with DCR. Note with integral dimming. Skinning not included.
- Provides 50/50% line operation via (2) independent dimes. Not available with PER, PER7, PR or PRR. Not available with P1, P2, P3, P4 or P5.
- Requires (2) separately switched circuits.
- Reference Motor Sensor table on page 3.
- Reference PER table on page 3 to see functionality.
- Must be ordered with NITAR2. For more information on [night Au 2](#) visit [this link](#).
- Not available with 347V, 480V, PNM1, DS. For PER5 or PER7, see PER Table on page 3. Requires isolated neutral.
- Not available with 347V, 480V, DS, BL30, BL50. For PER5 or PER7, see PER Table on page 3. Separate Dist to Drive required.
- Not available with order dimming controls options.
- Not available with BIC, ICCO and ICCO distribution. Also available as a separate accessory, see Accessories information.
- Must be ordered with fixture for factory pre-drilling.
- Requires fixture to be specified with PER, PER5 or PER7 option. See PER Table on page 3.
- For retrofit use only.

External Glare Shield

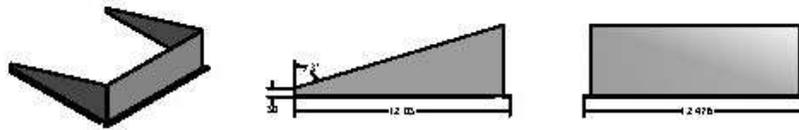

Drilling

HANDHOLE ORIENTATION

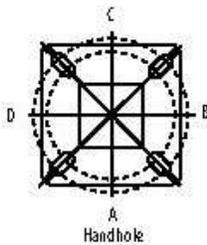

Tenon Mounting Slipfitter**

Tenon O.D.	Single Unit	2 at 180°	2 at 90°	3 at 120°	3 at 90°	4 at 90°
2-3/8"	AST20-190	AST20-280	AST20-290	AST20-320	AST20-390	AST20-490
2-7/8"	AST25-190	AST25-280	AST25-290	AST25-320	AST25-390	AST25-490
4"	AST35-190	AST35-280	AST35-290	AST35-320	AST35-390	AST35-490

Pole drilling nomenclature: # of heads at degree from handhole (default side A)						
DM19AS	DM28AS	DM29AS	DM32AS	DM39AS	DM49AS	
1 @ 90°	2 @ 280°	2 @ 90°	3 @ 120°	3 @ 90°	4 @ 90°	
Side B	Sides B & D	Sides B & C	Round pole only	Sides B, C, & D	Sides A, B, C, D	

Note: Review luminaire spec sheet for a specific nomenclature.

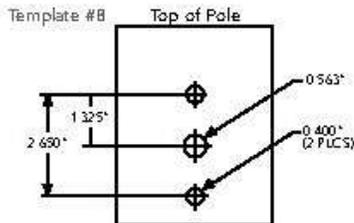

Pole top or tenon O.D.	1.5" @ 90°	4" @ 90°	3.5" @ 90°	7" @ 90°	4.5" @ 120°	4" @ 120°	1.5" @ 120°	7" @ 120°
DSX SPA	Y	Y	Y	N	-	-	-	-
DSX RPA	Y	Y	N	N	Y	Y	Y	Y
DSX PUMBA	Y	N	N	N	-	-	-	-
DSX RPU MBA	H	H	H	H	Y	Y	Y	H

33 fix (per @ 120) may use in individual application.

Photometric Diagrams

To see complete photometric reports or download .ies files for this product, visit [Lithonia Lighting's D-Series Area Size 1 homepage](#).

Isofootcandle plots for the DSX1 LED 60C 1000 40K. Distances are in units of mounting height (25')

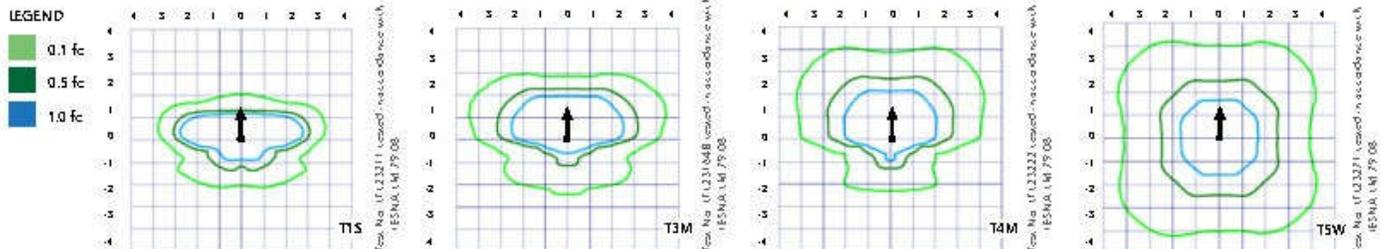

Performance Data

Lumen Ambient Temperature (LAT) Multipliers

Use these factors to determine relative lumen output for average ambient temperatures from 0-40°C (32-104°F).

Ambient	Lumen Multiplier
0°C	1.04
5°C	1.04
10°C	1.03
15°C	1.02
20°C	1.01
25°C	1.00
30°C	0.99
35°C	0.98
40°C	0.97

Projected LED Lumen Maintenance

Data references the extrapolated performance projections for the platforms noted in a 25°C ambient, based on 10,000 hours of LED testing (tested per IESNA LM-80-08 and projected per IESNA TM-21-11).

To calculate LLF, use the lumen maintenance factor that corresponds to the desired number of operating hours below. For other lumen maintenance values, contact factory.

Operating Hours	0	25000	50000	100000
Lumen Maintenance Factor	1.00	0.96	0.92	0.85

Electrical Load

Performance Package	LED Count	Drive Current	Voltage	Current (A)						
				120	208	240	277	347	480	
Forward Optics (Non-Rotated)	P1	30	530	54	0.45	0.26	0.23	0.19	0.10	0.12
	P2	30	700	70	0.59	0.34	0.30	0.25	0.20	0.16
	P3	30	1050	102	0.86	0.50	0.44	0.38	0.30	0.22
	P4	30	1250	125	1.06	0.60	0.52	0.46	0.37	0.27
	P5	30	1400	138	1.16	0.67	0.58	0.51	0.40	0.29
	P6	40	1250	163	1.36	0.78	0.68	0.59	0.47	0.34
	P7	40	1400	183	1.53	0.88	0.76	0.66	0.53	0.38
	P8	60	1050	207	1.74	0.98	0.87	0.76	0.64	0.49
	P9	60	1250	241	2.01	1.16	1.01	0.89	0.70	0.51
Rotated Optics (Requires 190 or 190)	P10	60	530	106	0.90	0.52	0.47	0.43	0.33	0.27
	P11	60	700	137	1.15	0.67	0.60	0.53	0.42	0.32
	P12	60	1050	207	1.74	0.99	0.87	0.76	0.60	0.46
	P13	60	1250	231	1.93	1.12	0.97	0.86	0.67	0.49

Motion Sensor Default Settings						
Option	Dimmed State	High Level (when triggered)	PhotoCell Operation	Dwell Time	Ramp-up Time	Ramp-down Time
PIR or PIRH	3v (37%) Output	10v (100%) Output	Enabled @ 5FC	5 min	3 sec	5 min
*PIR1FCV or PIRH1FCV	3v (37%) Output	10v (100%) Output	Enabled @ 1FC	5 min	3 sec	5 min

*For use with Inline Dial to Down or Timer.

Control	PER (3 wire)	PER5 (5 wire)		PER7 (7 wire)		
		Wire 4/Wire 5	Wire 4/Wire 5	Wire 6/Wire 7	Wire 6/Wire 7	
Photocontrol Only (On/Off)	✓	⚠	Wired to dimming leads on driver	⚠	Wired to dimming leads on driver	Wires Capped inside fixture
BOAM	✗	✓	Wired to dimming leads on driver	⚠	Wired to dimming leads on driver	Wires Capped inside fixture
BOAM with Motion BOAM on/off only	✗	⚠	Wires Capped inside fixture	⚠	Wires Capped inside fixture	Wires Capped inside fixture
Future-proof*	✗	⚠	Wired to dimming leads on driver	✓	Wired to dimming leads on driver	Wires Capped inside fixture
Future-proof* with Motion	✗	⚠	Wires Capped inside fixture	✓	Wires Capped inside fixture	Wires Capped inside fixture

- ✓ Recommended
- ✗ Not Allowed
- ⚠ Alternate

*Future-proof means Ability to change controls in the future.

FEATURES & SPECIFICATIONS

INTENDED USE

The sleek design of the D-Series Size 1 reflects the embedded high performance LED technology. It is ideal for many commercial and municipal applications, such as parking lots, plazas, campuses, and streetscaping.

CONSTRUCTION

Single-piece die-cast aluminum housing has integral heat sink fins to optimize thermal management through conductive and convective cooling. Modular design allows for ease of maintenance and future light engine upgrades. The LED drivers are mounted in direct contact with the casting to promote low operating temperature and long life. Housing is completely sealed against moisture and environmental contaminants (IP65). Low EFA (1.01 ft²) for optimized pole wind loading.

FINISH

Exterior parts are protected by a zinc-infused Super Durable TGIC thermoset powder coat finish that provides superior resistance to corrosion and weathering. A tightly controlled multi-stage process ensures a minimum 3 mils thickness for a finish that can withstand extreme climate changes without cracking or peeling. Available in both textured and non-textured finishes.

OPTICS

Precision-molded proprietary acrylic lenses are engineered for superior area lighting distribution, uniformity, and pole spacing. Light engines are available in standard 3000 K, 4000 K and 5000 K (70 CRI) configurations. The D-Series Size 1 has zero uplight and qualifies as a Nighttime Friendly™ product, meaning it is consistent with the LEED® and Green Globes™ criteria for eliminating wasteful uplight.

ELECTRICAL

Light engine configurations consist of high-efficacy LEDs mounted to metal-core circuit boards to maximize heat dissipation and promote long life (up to 185/100,000 hours at 25°C). Class 1

electronic drivers are designed to have a power factor >90%, THD <20%, and an expected life of 100,000 hours with <1% failure rate. Easily serviceable 10kV surge protection device meets a minimum Category C Low operation (per ANSI IEEE C62.41.2).

INSTALLATION

Included mounting block and integral arm facilitate quick and easy installation. Stainless steel bolts fasten the mounting block securely to poles and walls, enabling the D-Series Size 1 to withstand up to a 3.0 G vibration load (rating per ANSI C136.31). The D-Series Size 1 utilizes the AERIS™ series pole drilling pattern (template X8). Optional terminal block and NEMA photocontrol receptacle are also available.

LISTINGS

UL listed for wet locations. Light engines are IP66 rated, luminaires are IP65 rated. Rated for -40°C minimum ambient. U.S. Patent No. D672,492.5 International patent pending.

DesignLights Consortium® (DLC) Premium qualified product and DLC qualified product. Not all versions of this product may be DLC Premium qualified or DLC qualified. Please check the DLC Qualified Products list at www.designlights.org/QPL to confirm which versions are qualified.

International Dark-Sky Association (IDA) Fixture Seal of Approval (FSA) is available for all products on this page utilizing 3000K color temperature only.

WARRANTY

5-year limited warranty. Complete warranty terms located at www.aucitybrands.com/Customers/Resolutions/Terms_and_conditions.aspx.

Note: Actual performance may differ as a result of end-user environment and application. All values are design or typical values, measured under laboratory conditions at 25°C. Specifications subject to change without notice.

Performance Data

Lumen Output

Lumen values are from photometric tests performed in accordance with IESNA LM-79-08. Data is considered to be representative of the configurations shown, within the tolerances allowed by Lighting Facts. Contact factory for performance data on any configurations not shown here.

Forward Optics																								
LED Count	Drive Circuit	Power Package	System Watts	Dist. Type	30K (3,000 K, 70 CRI)					40K (4,000 K, 70 CRI)					50K (5,000 K, 70 CRI)					AMB PC (Number Photocell Converted)				
					Lumens	B	U	G	LPW	Lumens	B	U	G	LPW	Lumens	B	U	G	LPW	Lumens	B	U	G	LPW
30	530	P1	54W	T15	6,457	2	0	2	120	6,956	2	0	2	129	7,044	2	0	2	130	3,640	1	0	1	70
				T25	6,450	2	0	2	119	6,949	2	0	2	129	7,037	2	0	2	130	3,813	1	0	1	73
				T2M	6,483	1	0	1	120	6,984	2	0	2	129	7,073	2	0	2	131	3,689	1	0	1	71
				T35	6,279	2	0	2	116	6,764	2	0	2	125	6,850	2	0	2	127	3,770	1	0	1	73
				T3M	6,468	1	0	2	120	6,967	1	0	2	129	7,056	1	0	2	131	3,752	1	0	1	72
				T4M	6,327	1	0	2	117	6,816	1	0	2	126	6,902	1	0	2	128	3,758	1	0	1	72
				TFTM	6,464	1	0	2	120	6,963	1	0	2	129	7,051	1	0	2	131	3,701	1	0	1	71
				TSVS	6,722	2	0	0	124	7,242	3	0	0	134	7,334	3	0	0	136	3,928	2	0	0	76
				T55	6,728	2	0	1	125	7,248	2	0	1	134	7,340	2	0	1	136	3,881	2	0	0	75
				T5M	6,711	3	0	1	124	7,229	3	0	1	134	7,321	3	0	2	136	3,930	2	0	1	76
				TSW	6,667	3	0	2	123	7,182	3	0	2	133	7,273	3	0	2	135	3,820	3	0	1	73
				BIC	5,299	1	0	1	98	5,709	1	0	2	106	5,781	1	0	2	107					
				KCO	3,943	1	0	2	73	4,248	1	0	2	79	4,302	1	0	2	80					
				KCO	3,943	1	0	2	73	4,248	1	0	2	79	4,302	1	0	2	80					
30	700	P2	70W	T15	8,249	2	0	2	118	8,886	2	0	2	127	8,999	2	0	2	129	4,561	1	0	1	67
				T25	8,240	2	0	2	118	8,877	2	0	2	127	8,989	2	0	2	128	4,777	1	0	1	70
				T2M	8,283	2	0	2	118	8,923	2	0	2	127	9,036	2	0	2	129	4,622	1	0	2	68
				T35	8,021	2	0	2	115	8,641	2	0	2	123	8,751	2	0	2	125	4,724	1	0	1	69
				T3M	8,263	2	0	2	118	8,901	2	0	2	127	9,014	2	0	2	129	4,701	1	0	2	69
				T4M	8,083	2	0	2	115	8,708	2	0	2	124	8,818	2	0	2	126	4,709	1	0	2	69
				TFTM	8,257	2	0	2	118	8,896	2	0	2	127	9,008	2	0	2	129	4,638	1	0	2	68
				TSVS	8,588	3	0	0	123	9,252	3	0	0	132	9,369	3	0	0	134	4,922	2	0	0	72
				T55	8,595	3	0	1	123	9,259	3	0	1	132	9,376	3	0	1	134	4,863	2	0	0	72
				T5M	8,573	3	0	2	122	9,236	3	0	2	132	9,353	3	0	2	134	4,924	3	0	1	72
				TSW	8,517	3	0	2	122	9,175	4	0	2	131	9,291	4	0	2	133	4,787	3	0	1	70
				BIC	6,770	1	0	2	97	7,293	1	0	2	104	7,386	1	0	2	106					
				KCO	5,038	1	0	2	72	5,427	1	0	2	78	5,496	1	0	2	79					
				KCO	5,038	1	0	2	72	5,427	1	0	2	78	5,496	1	0	2	79					
30	1050	P3	102W	T15	11,661	2	0	2	114	12,562	3	0	3	123	12,721	3	0	3	125					
				T25	11,648	2	0	2	114	12,548	3	0	3	123	12,707	3	0	3	125					
				T2M	11,708	2	0	2	115	12,613	2	0	2	124	12,773	2	0	2	125					
				T35	11,339	2	0	2	111	12,215	3	0	3	120	12,370	3	0	3	121					
				T3M	11,680	2	0	2	115	12,582	2	0	2	123	12,742	2	0	2	125					
				T4M	11,426	2	0	3	112	12,309	2	0	3	121	12,465	2	0	3	122					
				TFTM	11,673	2	0	2	114	12,575	2	0	3	123	12,734	2	0	3	125					
				TSVS	12,140	3	0	1	119	13,078	3	0	1	128	13,244	3	0	1	130					
				T55	12,150	3	0	1	119	13,089	3	0	1	128	13,254	3	0	1	130					
				T5M	12,119	4	0	2	119	13,056	4	0	2	128	13,221	4	0	2	130					
				TSW	12,040	4	0	3	118	12,970	4	0	3	127	13,134	4	0	3	129					
				BIC	9,570	1	0	2	94	10,310	1	0	2	101	10,440	1	0	2	102					
				KCO	7,121	1	0	3	70	7,671	1	0	3	75	7,768	1	0	3	76					
				KCO	7,121	1	0	3	70	7,671	1	0	3	75	7,768	1	0	3	76					
30	1250	P4	125W	T15	13,435	3	0	3	107	14,473	3	0	3	116	14,657	3	0	3	117					
				T25	13,421	3	0	3	107	14,458	3	0	3	116	14,641	3	0	3	117					
				T2M	13,490	2	0	2	108	14,532	3	0	3	116	14,716	3	0	3	118					
				T35	13,064	3	0	3	105	14,074	3	0	3	113	14,352	3	0	3	114					
				T3M	13,457	2	0	2	108	14,497	2	0	2	116	14,681	2	0	2	117					
				T4M	13,165	2	0	3	105	14,182	2	0	3	113	14,362	2	0	3	115					
				TFTM	13,449	2	0	3	108	14,488	2	0	3	116	14,672	2	0	3	117					
				TSVS	13,987	4	0	1	112	15,068	4	0	1	121	15,259	4	0	1	122					
				T55	13,999	3	0	1	112	15,080	3	0	1	121	15,271	3	0	1	122					
				T5M	13,963	4	0	2	112	15,042	4	0	2	120	15,233	4	0	2	122					
				TSW	13,872	4	0	3	111	14,944	4	0	3	120	15,133	4	0	3	121					
				BIC	11,027	1	0	2	88	11,879	1	0	2	95	12,029	1	0	2	96					
				KCO	8,205	1	0	3	66	8,839	1	0	3	71	8,951	1	0	3	72					
				KCO	8,205	1	0	3	66	8,839	1	0	3	71	8,951	1	0	3	72					
30	1400	P5	138W	T15	14,679	3	0	3	106	15,814	3	0	3	115	16,014	3	0	3	116					
				T25	14,664	3	0	3	106	15,797	3	0	3	114	15,997	3	0	3	116					
				T2M	14,739	3	0	3	107	15,878	3	0	3	115	16,079	3	0	3	117					
				T35	14,274	3	0	3	103	15,377	3	0	3	111	15,572	3	0	3	113					
				T3M	14,704	2	0	3	107	15,840	3	0	3	115	16,040	3	0	3	116					
				T4M	14,384	2	0	3	104	15,496	3	0	3	112	15,692	3	0	3	114					
				TFTM	14,695	2	0	3	106	15,830	3	0	3	115	16,030	3	0	3	116					
				TSVS	15,283	4	0	1	111	16,464	4	0	1	119	16,672	4	0	1	121					
				T55	15,295	3	0	1	111	16,477	4	0	1	119	16,686	4	0	1	121					
				T5M	15,257	4	0	2	111	16,435	4	0	2	119	16,644	4	0	2	121					
				TSW	15,157	4	0	3	110	16,328	4	0	3	118	16,534	4	0	3	120					
				BIC	12,048	1	0	2	87	12,979	1	0	2	94	13,143	1	0	2	95					
				KCO	8,965	1	0	3	65	9,657	1	0	3	70	9,780	1	0	3	71					
				KCO	8,965	1	0	3	65	9,657	1	0	3	70	9,780	1	0	3	71					

Performance Data

Lumen Output

Lumen values are from photometric tests performed in accordance with IESNA LM-79-08. Data is considered to be representative of the configurations shown, within the tolerances allowed by lighting facts. Contact factory for performance data on any configurations not shown here.

Forward Optics																									
LED Count	Drive Current	Power Package	System Watts	Dist. Type	30K (3,000 K, 70 CRI)					40K (4,000 K, 70 CRI)					50K (5,000 K, 70 CRI)					AMBPC (Amber Phosphor Converted)					
					Lumens	B	U	G	LPW	Lumens	B	U	G	LPW	Lumens	B	U	G	LPW	Lumens	B	U	G	LPW	
40	1250	P6	163W	T15	17,654	3	0	3	108	19,018	3	0	3	117	19,259	3	0	3	118						
				T25	17,635	3	0	3	108	18,998	3	0	3	117	19,238	3	0	3	118						
				T2M	17,726	3	0	3	109	19,096	3	0	3	117	19,337	3	0	3	119						
				T35	17,167	3	0	3	105	18,493	3	0	3	113	18,727	3	0	3	115						
				T3M	17,683	3	0	3	108	19,049	3	0	3	117	19,290	3	0	3	118						
				T4M	17,299	3	0	3	106	18,635	3	0	4	114	18,871	3	0	4	116						
				TTM	17,672	3	0	3	108	19,038	3	0	4	117	19,279	3	0	4	118						
				TSVS	18,379	4	0	1	113	19,800	4	0	1	121	20,050	4	0	1	123						
				TS5	18,394	4	0	2	113	19,816	4	0	2	122	20,066	4	0	2	123						
				TSM	18,348	4	0	2	113	19,766	4	0	2	121	20,016	4	0	2	123						
				TSW	18,228	5	0	3	112	19,636	5	0	3	120	19,885	5	0	3	122						
				BIC	14,489	2	0	2	89	15,609	2	0	3	96	15,806	2	0	3	97						
				KCO	10,781	1	0	3	66	11,614	1	0	3	71	11,761	2	0	3	72						
				KCO	10,781	1	0	3	66	11,614	1	0	3	71	11,761	2	0	3	72						
				40	1400	P7	183W	T15	19,227	3	0	3	105	20,712	3	0	3	113	20,975	3	0	3	115		
T25	19,206	3	0					3	105	20,690	3	0	3	113	20,952	3	0	3	114						
T2M	19,305	3	0					3	105	20,797	3	0	3	114	21,060	3	0	3	115						
T35	18,696	3	0					3	102	20,141	3	0	3	110	20,396	3	0	4	111						
T3M	19,258	3	0					3	105	20,746	3	0	3	113	21,009	3	0	3	115						
T4M	18,840	3	0					4	103	20,296	3	0	4	111	20,553	3	0	4	112						
TTM	19,246	3	0					4	105	20,734	3	0	4	113	20,996	3	0	4	115						
TSVS	20,017	4	0					1	109	21,564	4	0	1	118	21,837	4	0	1	119						
TS5	20,033	4	0					2	109	21,581	4	0	2	118	21,854	4	0	2	119						
TSM	19,983	4	0					2	109	21,527	5	0	3	118	21,799	5	0	3	119						
TSW	19,852	5	0					3	108	21,386	5	0	3	117	21,656	5	0	3	118						
BIC	15,780	2	0					3	86	16,999	2	0	3	93	17,214	2	0	3	94						
KCO	11,742	2	0					3	64	12,649	2	0	3	69	12,809	2	0	3	70						
KCO	11,742	2	0					3	64	12,649	2	0	3	69	12,809	2	0	3	70						
60	1050	P8	207W					T15	22,490	3	0	3	109	24,228	3	0	3	117	24,535	3	0	3	119		
				T25	22,466	3	0	4	109	24,202	3	0	4	117	24,509	3	0	4	118						
				T2M	22,582	3	0	3	109	24,327	3	0	3	118	24,635	3	0	3	119						
				T35	21,870	3	0	4	106	23,560	3	0	4	114	23,858	3	0	4	115						
				T3M	22,527	3	0	4	109	24,268	3	0	4	117	24,575	3	0	4	119						
				T4M	22,038	3	0	4	106	23,741	3	0	4	115	24,041	3	0	4	116						
				TTM	22,513	3	0	4	109	24,253	3	0	4	117	24,560	3	0	4	119						
				TSVS	23,415	5	0	1	113	25,224	5	0	1	122	25,543	5	0	1	123						
				TS5	23,434	4	0	2	113	25,244	4	0	2	122	25,564	4	0	2	123						
				TSM	23,374	5	0	3	113	25,181	5	0	3	122	25,499	5	0	3	123						
				TSW	23,221	5	0	4	112	25,016	5	0	4	121	25,332	5	0	4	122						
				BIC	18,458	2	0	3	89	19,885	2	0	3	96	20,136	2	0	3	97						
				KCO	13,735	2	0	3	66	14,796	2	0	4	71	14,983	2	0	4	72						
				KCO	13,735	2	0	3	66	14,796	2	0	4	71	14,983	2	0	4	72						
				60	1250	P9	241W	T15	25,575	3	0	3	106	27,551	3	0	3	114	27,900	3	0	3	116		
T25	25,548	3	0					4	106	27,522	3	0	4	114	27,871	3	0	4	116						
T2M	25,680	3	0					3	107	27,664	3	0	3	115	28,014	3	0	3	116						
T35	24,870	3	0					4	103	26,791	3	0	4	111	27,130	3	0	4	113						
T3M	25,617	3	0					4	106	27,597	3	0	4	115	27,946	3	0	4	116						
T4M	25,061	3	0					4	104	26,997	3	0	4	112	27,339	3	0	4	113						
TTM	25,602	3	0					4	106	27,580	3	0	4	114	27,929	3	0	4	116						
TSVS	26,626	5	0					1	110	28,684	5	0	1	119	29,047	5	0	1	121						
TS5	26,648	4	0					2	111	28,707	5	0	2	119	29,070	5	0	2	121						
TSM	26,581	5	0					3	110	28,635	5	0	3	119	28,997	5	0	3	120						
TSW	26,406	5	0					4	110	28,447	5	0	4	118	28,807	5	0	4	120						
BIC	20,990	2	0					3	87	22,612	2	0	3	94	22,898	2	0	3	95						
KCO	15,619	2	0					4	65	16,825	2	0	4	70	17,038	2	0	4	71						
KCO	15,619	2	0					4	65	16,825	2	0	4	70	17,038	2	0	4	71						

Performance Data

Lumen Output

Lumen values are from photometric tests performed in accordance with IESNA LM-79-08. Data is considered to be representative of the configurations shown, within the tolerances allowed by Lighting Facts. Contact factory for performance data on any configurations not shown here.

Rotated Optics																														
LED Count	Drive Variant	Power Package	System Watts	Dist. Type	30K (3000 K, 70 CRI)					40K (4000 K, 70 CRI)					50K (5000 K, 70 CRI)					AAMPIC (Amber Phosphor Converted)										
					lumens	B	U	G	LPW	lumens	B	U	G	LPW	lumens	B	U	G	LPW	lumens	B	U	G	LPW						
60	530	P10	106W		T15	13,042	3	0	3	123	14,050	3	0	3	133	14,228	3	0	3	134	7,167	2	0	2	72					
					T25	12,967	4	0	4	122	13,969	4	0	4	132	14,146	4	0	4	133	7,507	2	0	2	76					
					T2M	13,201	3	0	3	125	14,211	3	0	3	134	14,401	3	0	3	136	7,263	2	0	2	73					
					T35	12,766	4	0	4	120	13,752	4	0	4	130	13,926	4	0	4	131	7,424	2	0	2	75					
					T3M	13,193	4	0	4	124	14,213	4	0	4	134	14,393	4	0	4	136	7,387	2	0	2	75					
					T4M	12,944	4	0	4	122	13,945	4	0	4	132	14,121	4	0	4	133	7,400	2	0	2	75					
					TFTM	13,279	4	0	4	125	14,305	4	0	4	135	14,486	4	0	4	137	7,388	1	0	1	74					
					TSVS	13,372	3	0	1	126	14,405	4	0	1	136	14,588	4	0	1	138	7,734	3	0	1	78					
					T55	13,260	3	0	1	125	14,284	3	0	1	135	14,465	3	0	1	136	7,641	3	0	0	77					
					T3M	13,256	4	0	2	125	14,281	4	0	2	135	14,462	4	0	2	136	7,737	3	0	2	78					
					T3W	13,137	4	0	3	124	14,153	4	0	3	134	14,322	4	0	3	135	7,522	3	0	2	76					
					BIC	10,906	3	0	3	103	11,749	3	0	3	111	11,898	3	0	3	112										
					KCO	7,789	1	0	3	73	8,391	1	0	3	79	8,497	1	0	3	80										
					KCO	7,779	4	0	4	73	8,380	4	0	4	79	8,486	4	0	4	80										
					60	700	P11	137W		T15	16,556	3	0	3	121	17,835	3	0	3	130	18,061	4	0	4	131	8,952	2	0	2	68
										T25	16,461	4	0	4	120	17,733	4	0	4	129	17,957	4	0	4	131	9,377	2	0	2	72
T2M	16,758	4	0	4						122	18,053	4	0	4	132	18,281	4	0	4	133	9,072	2	0	2	69					
T35	16,205	4	0	4						118	17,457	4	0	4	127	17,678	4	0	4	129	9,273	2	0	2	71					
T3M	16,748	4	0	4						122	18,042	4	0	4	132	18,271	4	0	4	133	9,227	2	0	2	70					
T4M	16,432	4	0	4						120	17,702	4	0	4	129	17,926	4	0	4	131	9,243	2	0	2	71					
TFTM	16,857	4	0	4						123	18,159	4	0	4	133	18,389	4	0	4	134	9,103	2	0	2	69					
TSVS	16,975	4	0	1						124	18,287	4	0	1	133	18,518	4	0	1	135	9,661	3	0	1	74					
T55	16,832	4	0	1						123	18,133	4	0	1	132	18,362	4	0	1	134	9,544	3	0	1	73					
T3M	16,828	4	0	2						123	18,128	4	0	2	132	18,358	4	0	2	134	9,665	3	0	2	74					
T3W	16,677	4	0	3						122	17,966	5	0	3	131	18,193	5	0	3	133	9,395	4	0	2	72					
BIC	13,845	3	0	3						101	14,915	3	0	3	109	15,103	3	0	3	110										
KCO	9,888	1	0	3						72	10,652	2	0	3	78	10,787	2	0	3	79										
KCO	9,875	4	0	4						72	10,638	4	0	4	78	10,773	4	0	4	79										
60	1050	P12	207W							T15	22,996	4	0	4	111	24,773	4	0	4	120	25,087	4	0	4	121					
										T25	22,864	4	0	4	110	24,631	5	0	5	119	24,943	5	0	5	120					
					T2M	23,277	4	0	4	112	25,075	4	0	4	121	25,393	4	0	4	123										
					T35	22,509	4	0	4	109	24,248	5	0	5	117	24,555	5	0	5	119										
					T3M	23,263	4	0	4	112	25,061	4	0	4	121	25,378	4	0	4	123										
					T4M	22,824	5	0	5	110	24,588	5	0	5	119	24,899	5	0	5	120										
					TFTM	23,414	5	0	5	113	25,223	5	0	5	122	25,543	5	0	5	123										
					TSVS	23,579	5	0	1	114	25,401	5	0	1	123	25,722	5	0	1	124										
					T55	23,380	4	0	2	113	25,187	4	0	2	122	25,506	4	0	2	123										
					T3M	23,374	5	0	3	113	25,181	5	0	3	122	25,499	5	0	3	123										
					T3W	23,165	5	0	4	112	24,955	5	0	4	121	25,271	5	0	4	122										
					BIC	19,231	4	0	4	93	20,717	4	0	4	100	20,979	4	0	4	101										
					KCO	13,734	2	0	3	66	14,796	2	0	4	71	14,983	2	0	4	72										
					KCO	13,716	4	0	4	66	14,776	4	0	4	71	14,963	4	0	4	72										
					60	1250	P13	231W		T15	25,400	4	0	4	110	27,363	4	0	4	118	27,709	4	0	4	120					
										T25	25,254	5	0	5	109	27,205	5	0	5	118	27,550	5	0	5	119					
T2M	25,710	4	0	4						111	27,696	4	0	4	120	28,047	4	0	4	121										
T35	24,862	5	0	5						108	26,783	5	0	5	116	27,122	5	0	5	117										
T3M	25,695	5	0	5						111	27,680	5	0	5	120	28,031	5	0	5	121										
T4M	25,210	5	0	5						109	27,158	5	0	5	118	27,502	5	0	5	119										
TFTM	25,861	5	0	5						112	27,860	5	0	5	121	28,212	5	0	5	122										
TSVS	26,043	5	0	1						113	28,056	5	0	1	121	28,411	5	0	1	123										
T55	25,824	4	0	2						112	27,819	5	0	2	120	28,172	5	0	2	122										
T3M	25,818	5	0	3						112	27,813	5	0	3	120	28,165	5	0	3	122										
T3W	25,586	5	0	4						111	27,563	5	0	4	119	27,912	5	0	4	121										
BIC	21,241	4	0	4						92	22,882	4	0	4	99	23,172	4	0	4	100										
KCO	15,170	2	0	4						66	16,342	2	0	4	71	16,549	2	0	4	72										
										15,150	5	0	5	66	16,321	5	0	5	71	16,527	5	0	5	72						

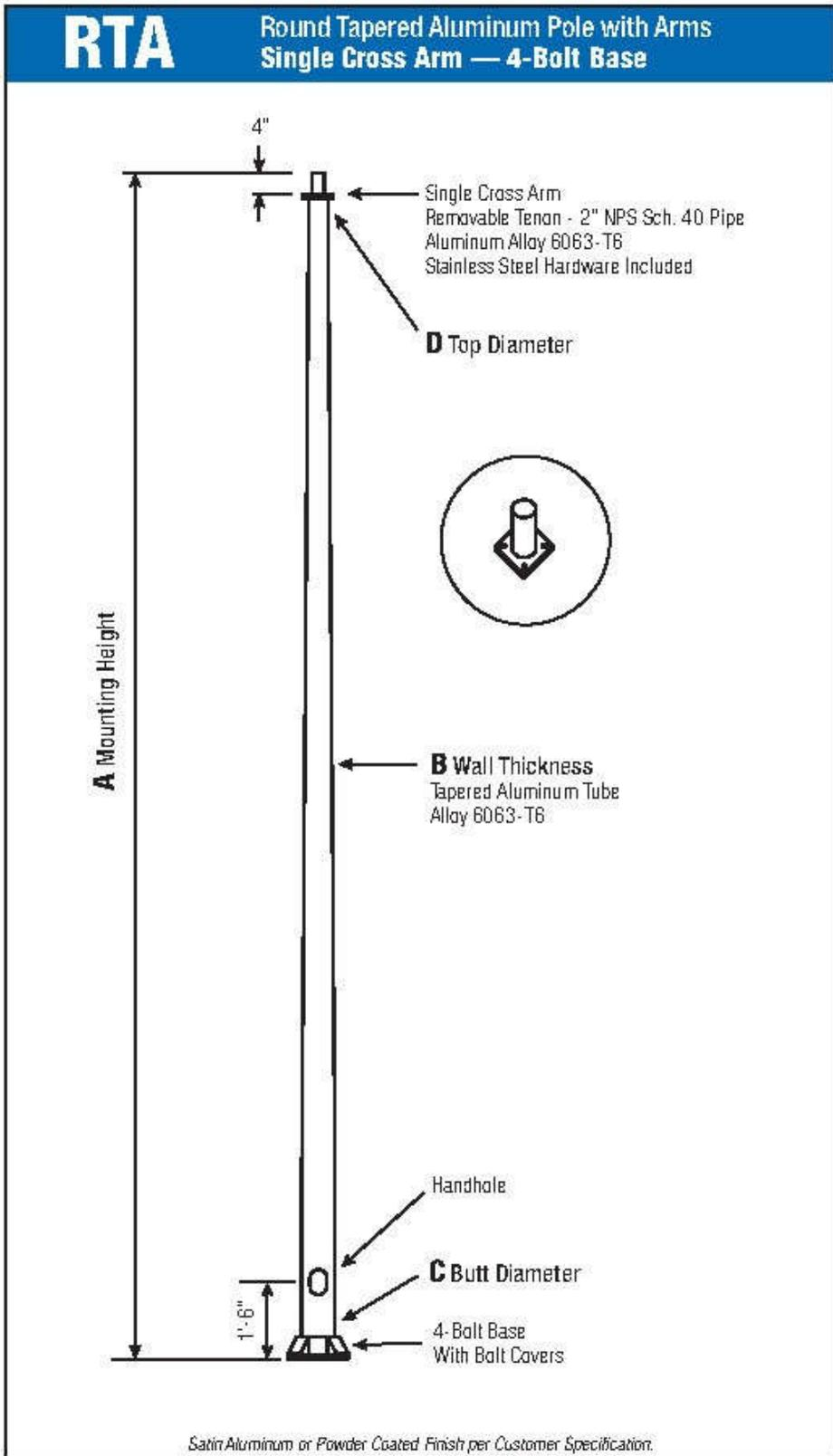

C Butt Dia.	D Top Dia.	F Bolt Cir. Dia.	G Base Sq.	H Bolt Proj.	I Bolt Size
6	4.5	9 - 10	9.75	2.75	1 x 36 x 4
7	4.5	10 - 11	10.5	2.75	1 x 36 x 4
8	4.5	11 - 12	11.25	2.75	1 x 36 x 4
10 Up To 290*	6	14 - 15	14	3.25	1 x 48 x 4
10 312* +	6	14 - 15	14	3.25	1.25 x 48 x 6
12*	6	16 - 18	17	3.75	1.25 x 48 x 6

*Two-Place Pole Design

Dimensions in Inches

Pole

Shaft and arm will be constructed of seamless extruded tube of 6063 Aluminum Alloy per the requirements of ASTM B221. The shaft assembly shall be full-length heat treated after base weld to produce a T6 temper.

Base Style

4-Bolt Cast Aluminum Base Flange of Alloy 356-T6 with Aluminum Bolt Covers (Alloy 356-F) and Stainless Steel Hex Head Attaching Screws.



Handhole

6" Butt Diameter - Reinforced, 3" x 5" curved Cast Aluminum Frame (Alloy 356-T6) with Aluminum Door and two (2) SS Hex Head Screws. A Grounding Provision incorporating a 3/8" diameter hole is provided opposite the Handhole.

7"+ Butt Diameters - Reinforced, 4" x 6" curved Cast Aluminum Frame (Alloy 356-T6) with Aluminum Door and two (2) SS Hex Head Screws. Reinforced Frame will contain a tapped 3/8"-16NC Grounding Provision.



Anchorage

Anchorage Kit will include four (4) L-shaped Steel Anchor Bolts conforming to AASHTO M314-90 Grade 55. Ten inches (10") of threaded end will be galvanized per ASTM A153. Kits will contain four (4) Hex Nuts, four (4) Lock Washers, and four (4) Flat Washers (all components Galvanized Steel). A bolt circle template will be provided.

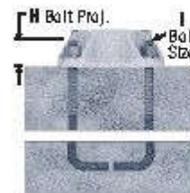
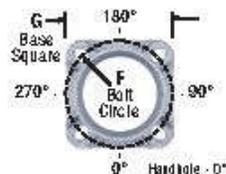

Vibration Damper

When determined necessary by Hapco, a Vibration Damper will be factory-installed inside the pole shaft. Customer specification of the damper is available.

A Mtg. Hgt.	B Wall Thickness	C Butt Diameter	Lum. Weight	MAXIMUM EPA					CATALOG NUMBER
				90	100	110	120	130	
20	0.156"	6	100	12.6	9.6	8.8	7.0	5.8	RTA20C6B4F10-**-
20	0.188"	6	100	15.8	12.2	11.2	9.2	7.6	RTA20D6B4F10-**-
20	0.156"	7	100	19.0	14.8	13.8	11.2	9.4	RTA20C7B4F10-**-
20	0.188"	7	100	23.6	18.4	17.0	14.0	11.8	RTA20D7B4F10-**-
20	0.188"	8	100	32.4	25.8	24.0	19.8	16.8	RTA20D8B4F10-**-
25	0.188"	6	85	10.0	7.4	6.6	5.2	4.2	RTA25D6B4F10-**-
25	0.156"	7	100	12.6	9.4	8.6	6.8	5.6	RTA25C7B4F10-**-
25	0.188"	7	100	16.0	12.2	11.2	9.0	7.4	RTA25D7B4F10-**-
25	0.156"	8	100	18.2	14.2	13.0	10.6	8.8	RTA25C8B4F10-**-
25	0.188"	8	100	22.8	17.8	16.4	13.4	11.2	RTA25D8B4F10-**-
25	0.219"	8	100	27.2	21.4	19.8	16.2	13.6	FTA25E8B4F10-**-
25	0.250"	8	100	31.4	24.8	23.0	19.0	15.8	FTA25F8B4F10-**-
30	0.188"	7	85	10.8	7.8	7.0	5.4	4.4	RTA30D7B4F10-**-
30	0.156"	8	100	12.4	9.2	8.4	6.6	5.4	RTA30C8B4F10-**-
30	0.188"	8	100	16.2	12.2	11.2	9.0	7.4	RTA30D8B4F10-**-
30	0.219"	8	100	19.6	15.0	13.8	11.2	9.4	FTA30E8B4F10-**-
30	0.250"	8	100	23.0	17.8	16.4	13.4	11.2	FTA30F8B4F10-**-
30	0.188"	10	100	29.6	23.6	22.0	18.2	15.2	RTA30D1C4F10-**-
30	0.219"	10	100	35.2	28.0	26.2	21.6	18.2	FTA30E1C4F10-**-
30	0.250"	10	100	40.8	32.6	30.4	25.2	21.2	FTA30F1C4F10-**-
30	0.312"	10	100	41.9	33.5	31.2	25.9	21.8	RTA30G1C4F10-**-
35	0.188"	8	90	11.2	8.2	7.4	5.6	4.6	RTA35D8B4F10-**-
35	0.219"	8	100	14.0	10.4	9.4	7.4	6.0	FTA35E8B4F10-**-
35	0.250"	8	100	16.8	12.6	11.6	9.2	7.6	FTA35F8B4F10-**-
35	0.188"	10	100	22.2	17.6	16.4	13.4	11.0	RTA35D1C4F10-**-
35	0.219"	10	100	27.0	21.4	19.8	16.4	13.6	FTA35E1C4F10-**-
35	0.250"	10	100	31.6	25.0	23.2	19.2	16.0	FTA35F1C4F10-**-
40	0.188"	8	40	7.6	5.2	4.4	3.2	2.4	RTA40D8B4F10-**-
40	0.219"	8	65	10.0	7.0	6.2	4.6	3.6	FTA40E8B4F10-**-
40	0.250"	8	90	12.2	8.6	7.8	6.0	4.8	FTA40F8B4F10-**-
40	0.188"	10	100	16.6	13.0	12.0	9.6	7.8	RTA40D1C4F10-**-
40	0.219"	10	100	20.6	16.2	15.0	12.2	10.0	FTA40E1C4F10-**-
40	0.250"	10	100	24.6	19.2	17.8	14.6	12.0	FTA40F1C4F10-**-
40	0.312"	10	100	32.0	25.4	23.6	19.4	16.2	RTA40G1C4F10-**-
45	0.188"	10	100	12.0	9.2	8.4	6.6	5.2	RTA45D1C4F10-**-
45	0.219"	10	100	15.4	12.0	11.0	8.8	7.0	FTA45E1C4F10-**-
45	0.250"	10	100	18.8	14.6	13.6	11.0	8.8	FTA45F1C4F10-**-
45	0.312"	10	100	25.4	20.0	18.4	15.0	12.4	RTA45G1C4F10-**-
45	0.250"	12	100	32.6	25.6	23.8	19.4	16.0	FTA45F2C4F10-**-
45	0.312"	12	100	41.8	33.4	31.0	25.6	21.2	RTA45G2C4F10-**-
45	0.375"	12	100	45.3	36.0	33.5	27.5	22.9	RTA45H2C4F10-**-

Catalog Number System

The catalog number for Hapco poles utilizes the following identification system.



Catalog Number Example -

RTA 30 D 8 B 4 F 1 0 - 01

Round Tapered Aluminum, 30' Mounting Height, .188" Wall Thickness, 8" Butt Diameter, 4.5" Top Diameter, 4-Bolt Base, Cross Arm, Single, No Arm Length, Satin Aluminum Finish.

Wall Thickness

- C = .156"
- D = .188"
- E = .219"
- F = .250"
- G = .312"
- H = .375"

Butt Diameter

- 6 = 6"
- 7 = 7"
- 8 = 8"
- 1 = 10"
- 2 = 12"

Top Diameter

- B = 4.5"
- C = 6"

Base Style

- 4 = 4-Bolt Base

Arm Style

- F = Cross Arm

Arm Quantity

- 1 = Single

Arm Length

- 0 = Standard Removable Tenon

Finish

- 01 = Satin Aluminum
- BA = Black Powder Coat
- BH = White Powder Coat
- BM = Dark Bronze Powder Coat
- BV = Dark Green Powder Coat
- GC = Gray Powder Coat
- ** = Specify Finish

EPA Notes:

Effective Projected Area (EPA) in square feet. EPA's calculated using wind velocity (mph) indicated in accordance with 2009 AASHTO L15-5 using a 25 year design life. Maximum EPA is based on the luminaire weight shown. Increased luminaire weight may reduce the maximum EPA. If weight is exceeded, or if other design life or code is required, please consult the factory.



WHY ROAM®?

ROAM is a wireless outdoor lighting management system that delivers flexible control strategies for minimizing maintenance costs, optimizing energy use and providing a safe nighttime environment. The comprehensive product portfolio is unlimited in scale and can be centrally or locally hosted. With numerous deployments across the U.S. and Canada, ROAM is the proven leader in wireless control solutions.

Customers significantly reduce operating costs and optimize the performance of outdoor lighting systems when using ROAM's award-winning technology. Through a robust mesh network, ROAM devices wirelessly communicate with a data center to deliver state-of-the-art monitoring, control and measurement.

ROAM also offers the flexibility customers need to fit a wide range of applications – from individual parking lots to large municipalities, new construction or retrofit. With a complete portfolio of solutions, ROAM has the right platform for every outdoor lighting need.

How ROAM Works

ROAM consists of a mesh network of intelligent photocontrols, or *nodes*, used to control 70-1000W, 120-480VAC LED, HID and other fixtures. Nodes monitor fixture performance and operating conditions, and execute commands based on inputs such as schedules and daylight levels. Information collected about fixture performance is wirelessly transmitted to a gateway and passed on to a server, where it is graphically displayed at a customer's workstation.

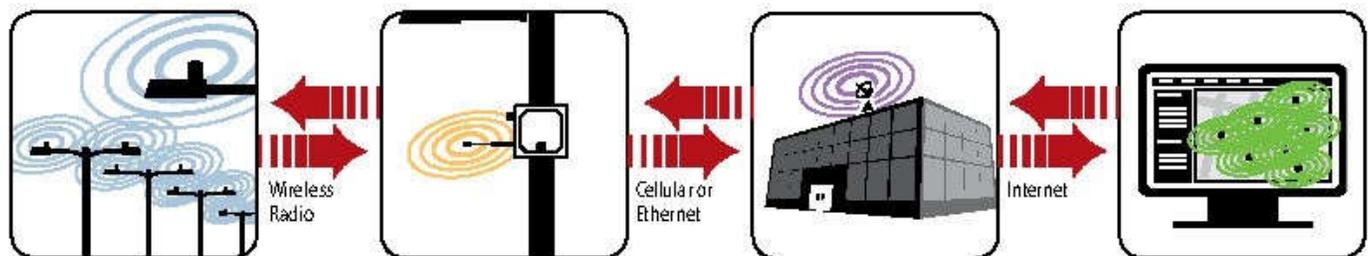

Smart Photocontrols

- Commands onboard dimming control modules
- Operates with any outdoor LED, HID or other fixtures
- Spacing can be up to 1,000 feet apart
- Provides increased surge protection for durability
- Up to 0.5% energy measurement accuracy

Gateway

- Receives data and transmits commands to nodes
- Communicates with up to 2,000 devices, reducing installed cost
- Uplinks via cellular or Ethernet communication
- Mounts on pole or building

Centrally or Locally Hosted Network Operation Center

- Receives and stores all data from Gateways
- Analyzes and stores fixture data on secure data servers
- Uses encryption scheme approved by NSA
- Operates without requiring customer-hosted hardware, software or IT support

Customer Portal

- Provides secure web-based user GIS map or dashboard graphic interface
- Displays operating conditions and performance data
- Controls and schedules ON/OFF/TRIM/DIM for individual fixtures or groups
- Manages lighting at one or multiple sites

FEATURES

ROAM DIAGNOSTICS OVERVIEW

- Fixture malfunction (lamp, ballast or starter failure)
- Cycling
- Dayburner
- No report (communication, power or equipment failure)
- Unspecified malfunction
- Power (power factor, KWH, voltage or power quality alerts)

SPECIFICATIONS

WIRELESS ENABLED COMMUNICATION

- 2.4GHz - IEEE 802.15.4 compatible
- FCC part 15 approved
- Range - 1,000 foot clear line of sight

WIRELESS CONTROL

- Remote on/off/dim control
- Grouped scheduling (energy savings)
- Silicon light sensor, 1.5ft turn-on, 2.25ft turn-off
- 25-1,000 watt fixtures; Voltage 70-305VAC 50/60Hz
- 1060JMOV - 10KA amp surge protection
- Zero cross relay switching for superior inrush protection
- Average Power consumption 1.6 watts
- Maximum Power consumption: 2.2 watts
- Complies with ANSI C136.10, ANSI C136.41, and FCC part 15
- -40 to +70°C ambient
- ANSI Standard 2 to 5 second turn off delay
- Automatically determines and reports fixture voltage and wattage
- Automatically determines lamp type (HID vs LED)
- Automatically determines if fixture is dimming enabled including low/high fixture wattage limits

REVENUE GRADE ENERGY MEASUREMENT

- Accuracy class of 0.5% per ANSI C12.20
- Dedicated energy computation processor
- Dedicated non-volatile memory
- Revenue grade energy measurement (0.5%) and reporting

INTEGRAL DIMMING (OPTIONAL)

- ANSI C136.41 compliant dimming interface
- 0-10 Volt Dimming
- Eliminates need for RDAM DCM module inside fixture
- Supports up to 5 drivers (2 mA per driver) sink or source operation

ON-BOARD GPS (OPTIONAL)

- Activation free installation
- Automatically determines and reports GPS location. Sub 2 meter accuracy typical

Warranty

Three-year limited warranty. Complete warranty terms located at: www.acuitybrands.com/CustomerResources/Terms_and_conditions.aspx

Note: Actual performance may differ as a result of end-user environment and application.

Specifications subject to change without notice.



ROAM.

REN127/347/480 DV

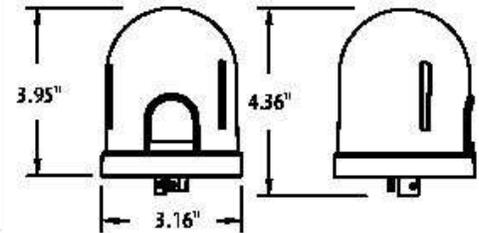

ORDERING INFORMATION

REN127 DV		Example: REN127 DV1 0 J50*			
Model & Voltage	Color	Certifications	Dimming Options	GPS	Job Packs ⁴
REN127 120/240/277V (70-305)	DVX ANSI STD ¹ (by voltage)	A CUL-US ²	D 0-10V Dimming	G GPS Enabled ⁶	[blank] 1 Unit
REN347 ⁶ 347V	DV1 Black ²	[blank] No Listing Required	[blank] No Dimming	[blank] No on-board GPS	J50 50 Count Pack
REN480 480V					M50 50 Master Pack

*For use with ROAM and ROAMview Systems.

1. 120-277 - Blue, 347 - Green, 480 - Yellow, All UL versions will conform to ANSI color.
2. Black cover cannot be provided with any agency listings.
3. Cover color will conform to ANSI color std (by voltage).

4. Must order 50 Master Pack (M50). Functionality not available with ROAMview.
5. Job Pack only determines packaging type. In order to receive 50 units, order line must include quantity 50.
6. 347 volt models only available with agency listings. See note 1.

Stocked Model Numbers

Model #	Description
REN127 DV1 0 J50	Multi-volt, Black Cover, Non-CULUS Listed, 0-10V Dimming
REN127 DV1 0 G M50	Multi-volt, Black Cover, Non-CULUS Listed, 0-10V Dimming, GPS Enabled
REN127 DVXA 0 J50	Multi-volt, Blue Cover, CULUS Listed, 0-10V Dimming
REN480 DV1 0 J50	480V, Black Cover, Non-CULUS Listed, 0-10V Dimming
REN480 DVXA 0 J50	480V, Yellow Cover, CULUS Listed, 0-10V Dimming

Models not listed above are subject to standard lead-time.

OVERVIEW

- 320J MOV - 9,500 amp surge protection
- Voltage 100-305 VAC
- -40 to +65°C ambient
- Wall or Mast arm mounting (1-3 inch pipe)
- Power indicator
- Powered through standard locking type receptacle on fixture
- -3 foot cable and locking type plug included
- Average power consumption: 5.5 watts
- Maximum power consumption: 12 watts
- Maximum EPA is 1.87 sq. ft.
- The unit weight is 7 lbs.
- Cast aluminum housing
- Cast aluminum articulating mounting bracket
- Fiberglass radio antenna
- Enclosure is IP66 rated

SPECIFICATIONS

**WIRELESS ENABLED BACKBONE AND DATA BACKHAUL DEVICE
WIRELESS ENABLED COMMUNICATION**

- 2.4 GHz- IEEE 802.15.4 compatible
- Cellular network uplink through GSM/GPRS
- Ethernet link for optional WAN connection via internet
- FCC part 15 approved
- CSA approved
- 1,000 foot clear line of site
- Supports up to 2,000 devices

Warranty

Three-year limited warranty. Complete warranty terms located at:
www.acuitybrands.com/CustomerResources/Terms_and_conditions.aspx

Note: Actual performance may differ as a result of end-user environment and application.

Specifications subject to change without notice.



REG127
Gateway

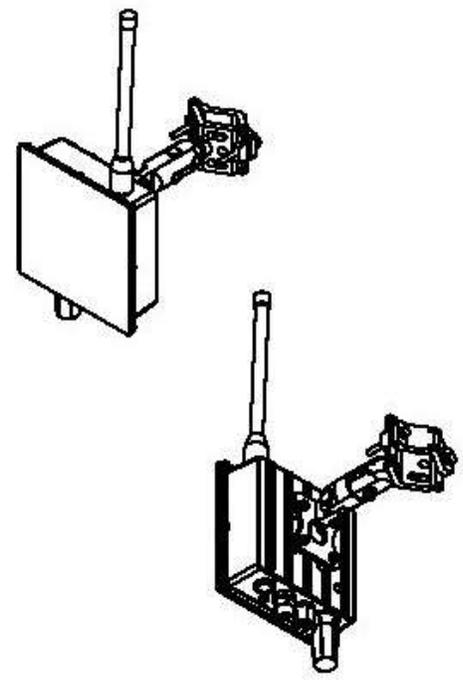

ORDERING INFORMATION

REG127		Example: REG127 WX5*	
Model & Voltage	Model	Color	System
REG127 120/240/277V (100-305)	EX Compact Mast Arm Mount - Ethernet WX* Compact Mast Arm Mount - Wireless	5 Gray	[blank] ROAM V ROAMview E Enterprise

*Not available with ROAMview

DIMENSIONS

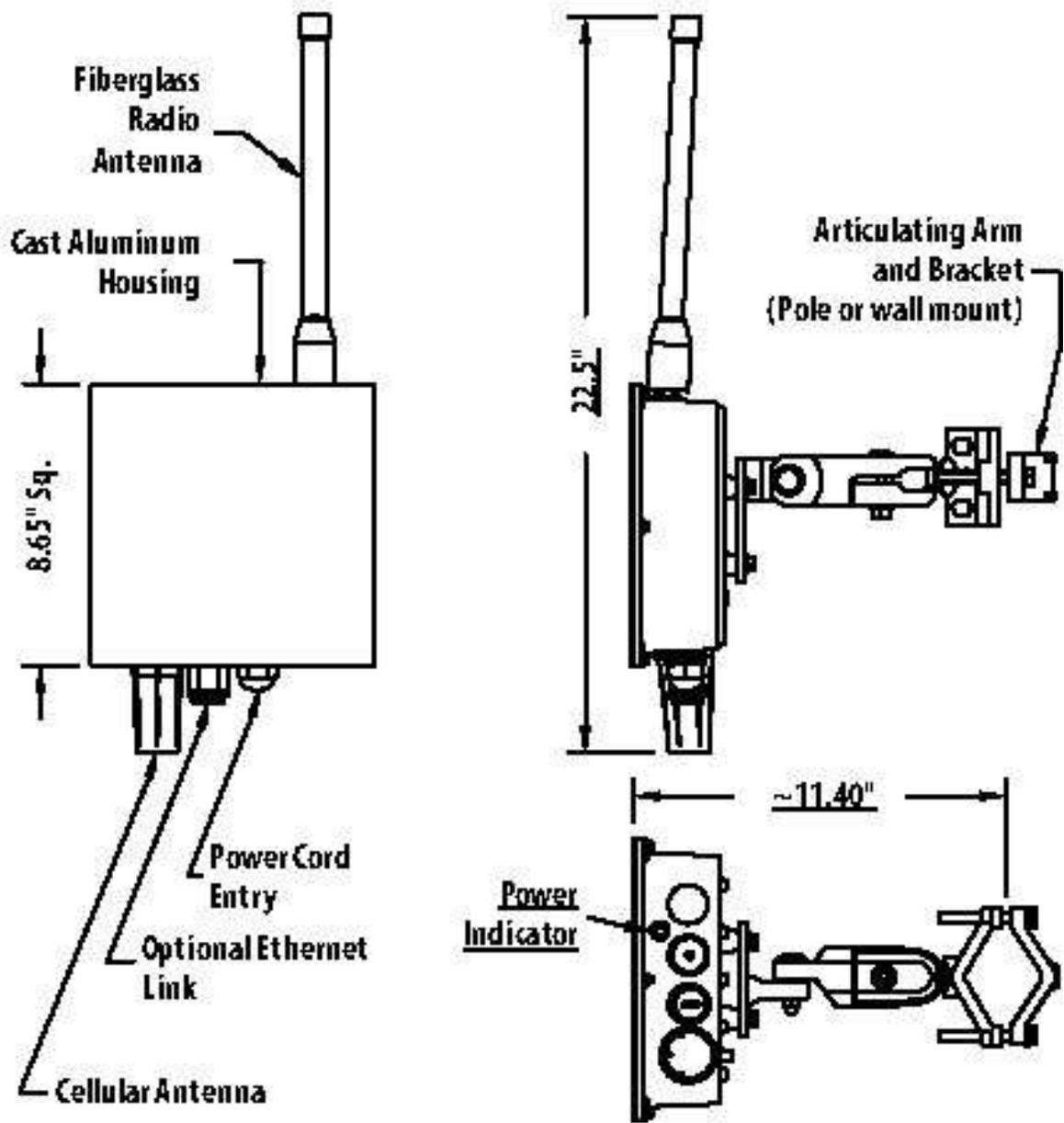

11.3. Emergency Call Box

A minimum of (1) one Emergency Phone and Call Box shall be provided at each transit/park & ride site. The emergency call box is proposed to be located near the bus plaza drop off area and be ADA compliant and designed, for reliability and ease of use. The emergency telephone is to provide reliable emergency communication without complicated dialing procedures. The proposed emergency phone shall be suitable for outdoor use and shall be programmed to automatically dial 911 or any other designated emergency number. Users need only to simply depress the push to talk button to place a call for help. The call box handset shall be covered by a protective outer door, mounted so that it helps shield environmental sound while the call box is in use. Power for all call box functions shall be provided.

The proposed Cellular Call Box System shall operate in one of three functional modes: the quiescent mode, the active mode, or the standby mode. The call box shall be in the quiescent mode for the majority of each 24-hour day. In the quiescent mode, the call box controller powers down all but the essential electronics. This reduces the overall power requirement of the call box significantly. The call box shall be capable of operating for approximately 27 days on a fully charged battery if operating in the quiescent mode. In the quiescent mode, the call box monitors internal and external sensors continuously. If the status of any of these sensors requires action, the call box controllers will wake up the necessary electronic circuits and transition into the active mode

All call box electronics, including the cellular transceiver, are powered up when in the active mode. In this mode, the cellular transceiver can transmit and receive voice and data, allowing the call box to make one of the following phone calls, depending on the condition causing it to enter the active mode:

1. Program Call
2. Motorist Call
3. Report Call
4. Alarm Call
5. Electronic Access Call

The call box shall meet the following performance requirements: Report calls shall be made by the call box at intervals that have been programmed by the maintenance computer. At the report call time, the call box controller transitions the call box into the active state and places a telephone call to the maintenance computer. When the telephone link is established, the maintenance computer will poll the call box for status.

The call box will respond with the status of the following items:

1. Outer Door Open or Closed
2. Lamp Pass or Fail
3. Handset Good or Bad
4. Battery Voltage Acceptable or Unacceptable
5. Microprocessor Initialization Pass or Fail
6. AC/DC Module Disconnected
7. No DC Power Detected for 24 Hours
8. Inner Door Open or Closed
9. Call Box Standing or Tilted
10. Excessive Cellular Call Attempts
11. Incomplete Maintenance Programming
12. Radio Frequency Signal Strength
13. Recent Account of Call Usage to the Answer Center

The call box shall come with a minimum 10-year warranty period commencing from the date of final acceptance. The Contractor shall furnish and install all equipment necessary in accordance with the manufacturer's specifications for the full operation of the Emergency Call Box system. This includes but is not limited to the transceiver, AC/DC power supply, call box, battery, antenna, pole, foundation and foundation bolts, signage, and strobe assembly.



EMERGENCY PHONE MOUNTS

ETP-MT/R OP PCS – Wireless/Switched Power Emergency Phone Tower

Description

Talk-A-Phone's ETP-MT/R OP PCS Emergency Phone Tower is an ideal security solution for remote and high-risk areas. Standing over nine feet tall, this vandal-resistant tower serves as a great deterrent to crime. An always-lit LED Blue Light mounted atop the tower provides high visibility and gives passers-by a sense of security. Emergency call can be placed with a simple push of a button. At the same time, the LED Blue Light begins to flash, attracting attention to the location. The Emergency Phone faceplate is illuminated at all times for clear visibility during the night.

Talk-A-Phone's ETP-MT/R OP PCS Emergency Phone Tower accommodates a Power Charging System (purchased separately) for switched power and/or a wireless interface for greater deployment flexibility. They are often used at university and college campuses, parking facilities, shopping malls, medical centers, industrial campuses, transit facilities and remote areas with access to switching power.

Features

- Internal shelf and removable mounting plate facilitate the storage and organization of power and wireless components. Built-in louvers allow for ventilation.
- Attention-getting LED Blue Light is included and mounted atop the unit. The LED Blue Light is continuously lit and flashes for duration of a call when "EMERGENCY" button is pressed to draw attention to the unit.
- LED Blue Light is housed in a protective polycarbonate housing (except OP4, OP5)
- Emergency Phone faceplate is illuminated at all times by an LED Panel Light
- Vandal-resistant structure and coating designed to resist extreme weather conditions
- A variety of signage, graphics and color choices are available
- ADA-compliant

Specifications

Dimensions (W x D x H):	12.0 x 10.0 x 108.0 in. (305 x 254 x 2743 mm) with 2 in. radius corners
Weight:	350 lbs. (159 kg)
Construction:	0.25 in. steel
Coating:	High-gloss, multi-layer, corrosion-inhibitive system with resistance to UV-fade and graffiti protection
Colors:	Safety Blue is standard. Available in custom colors.
Signage:	3.25 in. high reflective white "EMERGENCY" lettering with wide-angle visibility is standard. Available in custom colors, lettering and graphics.
Lighting:	<p>LED Blue Light: 209 lumens peak, 78 flashes per minute, 70% of initial lumens after 50,000 hours of operation</p> <p>LED Panel Light: Ultra bright LEDs, 50,000 hour lifetime</p>
Power:	<p>LED Blue Light: 7.8 watts, 120VAC 7.8 watts, 12-24VDC/24VAC</p> <p>LED Panel Light: 1.2 watts, 12-120VAC/DC</p>
Compliance:	CSA Certified to UL Standard 60950 
Mounting:	Mounts into concrete foundation using included hardware (shipped in advance). Mounting options available for pre-poured parking decks.
Warranty:	5-year warranty on tower (2-year warranty on electronics)



ETP-MT/R OP PCS – Wireless/Switched Power Emergency Phone Tower

Options

ETP-MT/R-OP-PCS Configuration	Emergency Phone Options	Tower Options
Analog Connectivity	ETP-400 Series Phone	ETP-MT/R-OP-PCS-W1 includes a $\varnothing 3/4"$ opening with a plug and a gasket for mounting your own antenna.
		ETP-MT/R-OP-PCS-W2 includes a $\varnothing 2.5"$, 18" L pole above the tower for mounting your own pole-mounted wireless adapter.
IP Connectivity	VOIP-500 Series Phone	ETP-MT/R-OP-PCS-W3 for custom wireless deployments.
		ETP-MT/R-OP-PCS-OP2 includes a housing for mounting your own fixed CCTV camera inside the tower at average face height.
		ETP-MT/R-OP-PCS-OP3 includes a Honeywell fixed day/night CCTV camera inside the tower at average face height.
		ETP-MT/R-OP-PCS-OP4 includes an arm for mounting your own CCTV dome camera above the tower.
		ETP-MT/R-OP-PCS-OP5 includes an arm for mounting an AD Speed-Dome Ultra camera above the tower.

ETP-MT/R-OP-PCS tower includes a LED Blue Light, a LED Panel Light and an Anchor Bolt Kit. Emergency Phone is purchased separately.

Accessories

Parking Deck Mounting Kit:

Order model **ETP-PDMK-4** to mount on pre-poured parking deck.

Cellular Interface Kit:

Order model **ETP-CI** to create a stand-alone cellular communications tower when used in conjunction with an ETP-400 series emergency phone (for use with ETP-MT/R-OP-PCS-W1 tower only).

Power Charging System:

Order **PCS** series power charging system to include the battery backup when used with switched power sources.

Dimensional Diagram

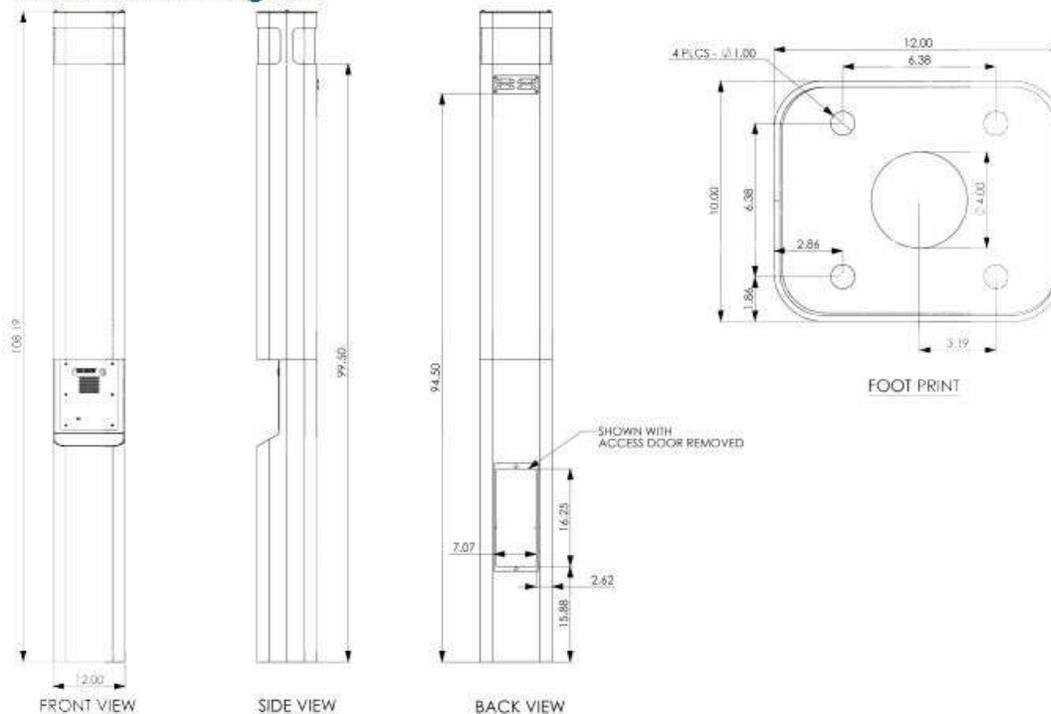

All dimensions are in inches and are provided for reference only.

Rev. 10/26/11

Copyright 2011 Talk-A-Phone Co. • 7530 North Natchez Avenue • Niles, Illinois 60714 • Phone 773.539.1100 • info@talkaphone.com • www.talkaphone.com.
All prices and specifications are subject to change without notice. Talk-A-Phone is a registered trademark of Talk-A-Phone Co. All rights reserved.



TALKAPHONE



ETP-500 SERIES CALL STATION

CALL STATIONS

11

ETP-500 SERIES OUTDOOR-RATED, ADA-COMPLIANT HANDS-FREE CALL STATIONS GO BEYOND EMERGENCY COMMUNICATIONS WITH A CLEAN AND SIMPLE INTERFACE, 316 MARINE GRADE STAINLESS STEEL AND ARE IP66 WATER RATED FOR HARSH ENVIRONMENTS

FEATURES

- Vandal resistant 316 marine grade stainless steel faceplate
- IP66 water resistant construction
- Raised letter and braille signage for ADA compliance
- Stainless steel metal button designed for long lasting usage and weather erosion
- Two LED indicators for hearing impaired (calling, answered)
- Uses regular phone lines for communications and function: no power supply or battery back-up needed
- Built-in auto-dialer can dial two numbers: if first number doesn't answer or is busy, dials next number
- Auto-answer allows security to monitor and initiate calls with the unit
- Ability to automatically identify attendant of location of calling phone by recorded message and digital display
- Auxiliary input and outputs to integrate with CCTV, Blue Light, Scream Alert™ and other devices

GENERAL SPECIFICATIONS	ETP-500 Series
Construction:	0.086 in (2.13mm) #4 brushed 316 stainless steel faceplate
Dimensions (W x H x D):	Front Panel: 8.5 x 11.5 in. (216 x 292 mm) Back Box: 6.38 x 9.79 x 2.83 in. (162 x 249 x 72 mm)
Weight:	5 lbs. (3.6 kg)
Storage Temperature:	-40° F to +149° F (-40° C to +65° C)
Operating Temperature:	-40° F to +131° F (-40° C to +55° C)
Relative Humidity:	Up to 95% non-condensing
Protection:	IP66, Circuit board conformal coated
Mounting:	Flush mount (kit sold separately) Surface mount options available
Communication:	2-way hands-free communication
Digit Capacity:	Up to 18 digits, including pauses, for each of two phone numbers
Dialing Speed:	Approximately 10 tones per second
Power Source:	Phone line powered (requires 20mA at 24 V off-hook)
Connection:	Parallel tip and ring connected to RJ11 connector for quick installation
Circuit Protection:	Varistor lightning suppressed and full wave polarity guarded
Programming:	Non-volatile EEPROM programming can be done from any telephone No battery back up is needed
"On Time":	Programmable from 1-4270 minutes in 1-minute increments
Recommended Wiring:	1 twisted-shielded pair
Approvals:	ETL Listed -- Conforms to ANSI/UL Standards 60950-1 and 60950-22. Certified to CAN/CSA Standard C22.2 Nos. 60950-1 and 60950-22. 



ETP-500C



ETP-500ECK

TALK-A-PHONE CO. LIMITED WARRANTY

Talk-A-Phone Co. warrants Talk-A-Phone Emergency Phone, Wide-Area Emergency Broadcast System (WEBS®), and Area of Rescue equipment against any defects in material and workmanship, under normal use, for a period of twenty-four (24) months from date of installation, provided that Talk-A-Phone receives a completed "Installation Certification" certifying the date on which the system has been installed. An "Installation Certification" card is enclosed with every unit. In the event that no "Installation Certification" is received by Talk-A-Phone, the twenty-four (24) months will commence on the date of shipment by Talk-A-Phone. Warranty period for Models ETP-MT Tower, ETP-MT/R Radius Tower, WEBS-MT/R Radius Tower, WEBS-PM Pedestal Mount, and ETP-PM Pedestal Mount is five (5) years, under the same terms and conditions. Warranty period for Intercommunication Products is three (3) months, under the same terms and conditions. In the event this product is found by Talk-A-Phone to be defective within the warranty period, Talk-A-Phone's only obligation and your exclusive remedy, shall be the repair and/or replacement of any defective parts, provided the equipment is returned to Talk-A-Phone Co., 7530 N. Natchez Ave., Niles, IL 60714. It is expressly understood that Talk-A-Phone shall have no obligation to furnish labor, nor pay for the labor of any third parties, nor bear the expense of shipping defective products for repair. This warranty shall not apply if Talk-A-Phone determines that the defect was caused by improper use or installation, or damage caused to the equipment by others.

THIS WARRANTY GIVES YOU SPECIFIC LEGAL RIGHTS AND YOU MAY ALSO HAVE OTHER RIGHTS WHICH VARY FROM STATE TO STATE.

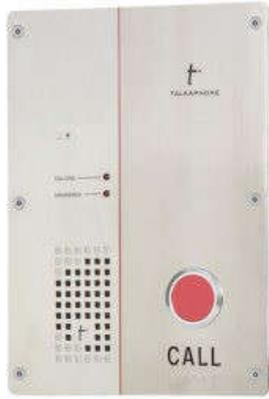
	ETP-500E- Single Button Emergency Call Station	ETP-500C- Single Button Call Station
		
Model:	ETP-500E: Emergency Call Station	ETP-500C: Single Button Call Station
Dimensions (W x H x D):	Front Panel: 8.5 x 11.5 in. (216 x 292 mm) Back Box: 6.38 x 9.79 x 2.83 in. (162 x 249 x 72 mm)	Front Panel: 8.5 x 11.5 in. (216 x 292 mm) Back Box: 6.38 x 9.79 x 2.83 in. (162 x 249 x 72 mm)
Weight:	5 lbs. (3.6 kg)	5 lbs. (3.6 kg)
	ETP-500EI- Dual Button Emergency Call Station	ETP-500ECK- Keypad Call Station
		
Model:	ETP-500EI: Dual Button Emergency Call Station	ETP-500ECK: Keypad Call Station
Dimensions (W x H x D):	Front Panel: 8.5 x 11.5 in. (216 x 292 mm) Back Box: 6.38 x 9.79 x 2.83 in. (162 x 249 x 72 mm)	Front Panel: 8.5 x 11.5 in. (216 x 292 mm) Back Box: 6.38 x 9.79 x 2.83 in. (162 x 249 x 72 mm)
Weight:	5 lbs. (3.6 kg)	5 lbs. (3.6 kg)

All specifications are subject to change without notice.

DIMENSIONAL DRAWING

All dimensions are in inches and are provided for reference only.

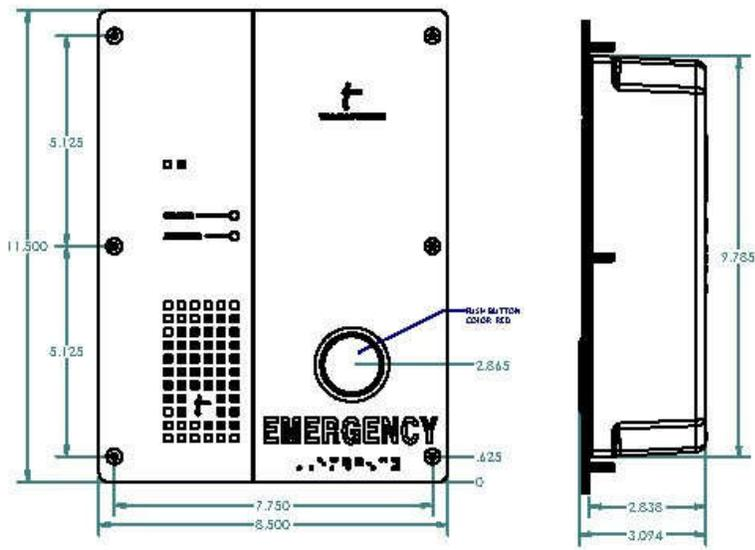

FRONT VIEW

SIDE VIEW

BOTTOM VIEW

Retrofit Alternative Manufacturer Towers:

Add to Model:	Description:
-GA	Faceplate fits Gai-tronics towers with adapter bracket (ADAPT-56-GA) (e.g. ETP-500E-GA)
-RH	Faceplate fits Rath Microtech towers (e.g. ETP-500E-RH)
-RM	Faceplate fits Ramtel towers with adapter bracket (ADAPT-56-RM) (e.g. ETP-500E-RM)

NOTE: Retrofit models may differ in size, style, and appearance in order to fit existing housing

Options

Add to Model:	Description:
E	Emergency (e.g. ETP-500E)
C	Call (e.g. ETP-500C)
EI	Two button-Emergency & Info (e.g. ETP-500EI)
K	Keypad (e.g. ETP-500K)
G	Handset (e.g. ETP-500G)

Custom Signage:

Custom signage is available, including Braille and silkscreen, in a variety of languages.



TALKAPHONE

THE LEADERS IN SECURITY AND LIFE SAFETY COMMUNICATIONS

7530 North Natchez Avenue
Niles, Illinois 60714

Tel: 773-539-1100
Email: info@talkaphone.com
Web: www.talkaphone.com

Rev. 07.15.2016



ETP-GSM – Cellular Interface Installation Instructions

I. Introduction

The **ETP-GSM** is used in conjunction with an ETP-400 Series ADA-compliant, hands-free Emergency Phone.

II. Contents

Before beginning installation, make sure you have all the included components. The **ETP-GSM** includes:

Qty.	Part Number	Description
1		GSM Cellular Interface
1	68416GSM	Remote-mounting Omni-directional Antenna
1	19679	Antenna Mount with Cable Assembly
1	42929	Torx T10 L-Key
2	4247	8-32 x 1/2 BH Screw
2	4248	8-32 x 5/16 Hex Nut
2	42767	#10 External Lock Washer

III. Installing the Antenna

The **ETP-GSM** Cellular Interface includes a remote-mounting omni-directional antenna. The remote-mounting antenna should be attached to the Talk-A-Phone enclosure (e.g. ETP-MT/R-OP-SOLAR tower) via the built-in antenna mounting hole. To install the remote-mounting antenna, please follow the separate antenna mount instructions included with the remote-mounting omni-directional antenna.

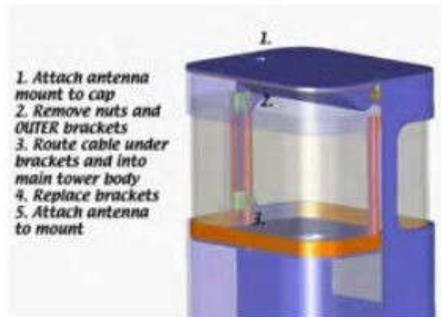

Figure 1. An example of mounting the remote-mounting antenna onto the cap of an ETP-MT/R-OP-PCS tower.

The remote-mounting antenna will be connected to the **ETP-GSM** Cellular Interface.



ETP-GSM – Cellular Interface Installation Instructions

IV. Installing the Cellular Interface

1. The front panel of the **ETP-GSM** Cellular Interface provides the following:
 - (1) Cellular signal strength indicator;
 - (2) LED indicators for **POWER**, **CELLULAR**, and **STATUS**;
 - (3) **PHONE-FXS** port for connecting to an ETP-400 Series Phone.



Figure 2. Front panel of the ETP-GSM Cellular Interface.



ETP-GSM – Cellular Interface Installation Instructions

2. The rear panel of the **ETP-GSM** Cellular Interface provides the following:
 - (1) Input terminal for 12VDC;
 - (2) Connector for remote-mounting omni-directional antenna;
 - (3) A serial port (for Talk-A-Phone Technical Support purposes only).

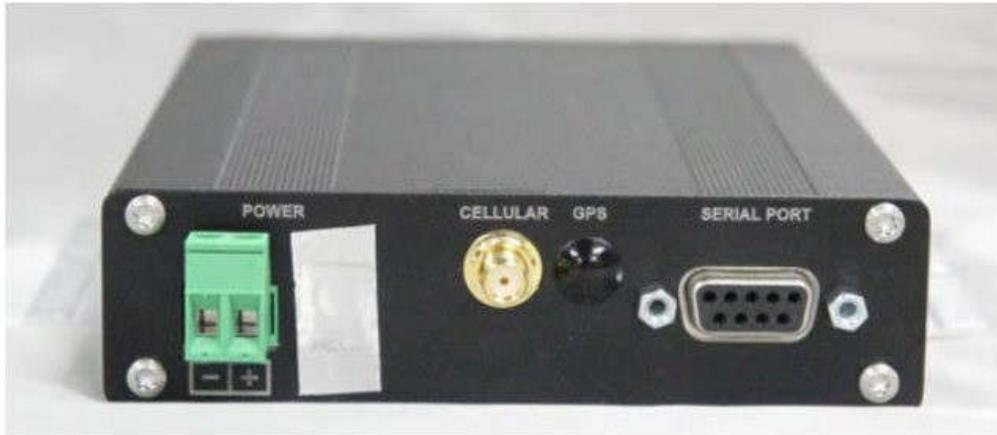

Figure 3. Rear panel of the ETP-GSM Cellular Interface.

3. Using the supplied Torx T10 L-Key, remove the Torx T10 screws from the rear panel (i.e. the panel with the 12VDC, antenna, and FXS connectors).
4. Carefully slide out the electronic board from the **ETP-GSM** Cellular Interface chassis.



ETP-GSM – Cellular Interface Installation Instructions

5. Locate the SIM card holder (see *Figure 4*).



Figure 4. Location of the SIM card holder.



ETP-GSM – Cellular Interface Installation Instructions

6. Unlock the SIM card holder and flip open the tray.



Figure 5. The SIM card holder unlocked and flipped open.



ETP-GSM – Cellular Interface Installation Instructions

7. **IMPORTANT:** Note the orientation of the angled notch on both the SIM card and the SIM card holder.

Insert the SIM card into the SIM card holder according to the location of the angled notch and gold contacts (see *Figure 6*).



Figure 5. The tray of the SIM card holder in the open position. Note the SIM card that has been installed into the tray.



ETP-GSM – Cellular Interface Installation Instructions

8. Flip the tray back to the closed position. Lock the SIM card holder by sliding the tray in the direction of the arrow located on the tray. *Figure 7* illustrates a SIM card locked into the SIM card holder.



Figure 7. SIM card installed and locked into the SIM card holder.

9. Carefully slide the electronic board back into the **ETP-GSM Cellular Interface** chassis.
10. Using the supplied Torx T10 L-Key, reinstall the Torx T10 screws.
11. Connect the cable assembly from the remote-mounting omni-directional antenna to the **CELLULAR** connector.
12. Connect the ETP-400 Series Phone to the **PHONE-FXS** port.
13. If a **SOLAR KIT** is used, connect the 12VDC battery according to the polarity markings on the 12VDC input terminal. Otherwise, connect a 12VDC power source appropriately with respect to polarity.



ETP-GSM – Cellular Interface Installation Instructions

14. Using the built-in mounting flanges, attach the **ETP-GSM** Cellular Interface onto the internal mounting panel of the Talk-A-Phone enclosure (e.g. ETP-MT/R-OP-SOLAR). The **ETP-GSM** Cellular Interface should be mounted so that the 12VDC input terminal is on the lower right corner (i.e. toward the Earth).

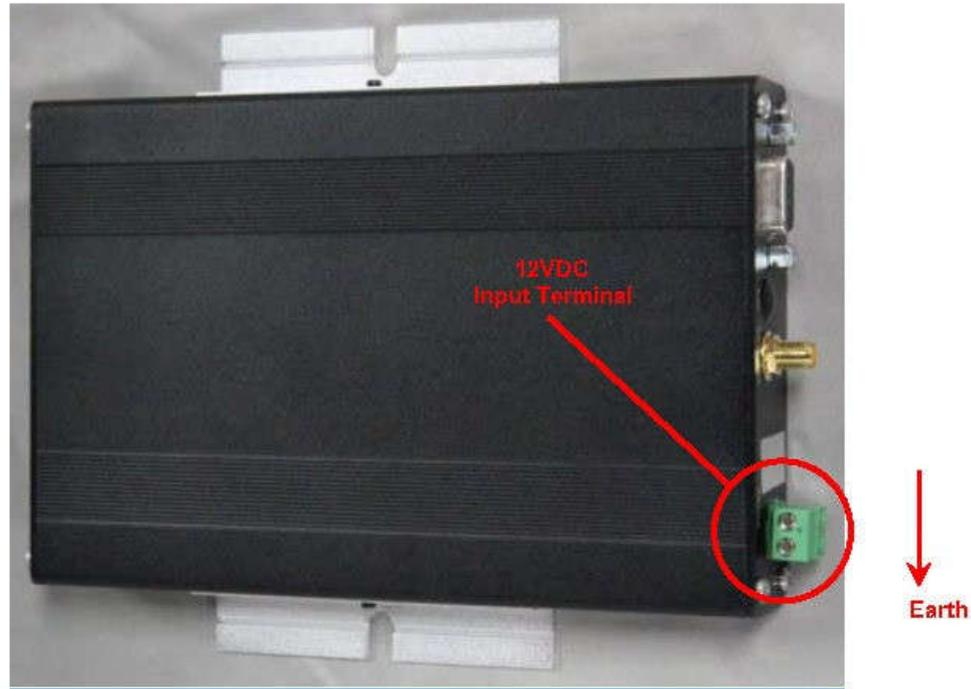

Figure 8. This photo illustrates the appropriate mounting position and orientation for the ETP-GSM Cellular Interface.



ETP-GSM – Cellular Interface Installation Instructions

V. Activation of Cellular Service

Select a local cellular service provider that supports GSM (e.g. AT&T, T-Mobile). Per the aforementioned installation instructions, install an activated SIM card provided by the local cellular service provider into the **ETP-GSM Cellular Interface**.

VI. Programming the ETP-400 Series Phone

The ETP-400 Series Phone requires specific programming for operation with the **ETP-GSM Cellular Interface**. At minimum, the ETP-400 Series Phone should be programmed with the following codes:

```
* 13 * <Phone_Number> # *
* 14 * 3 *
* 18 * 5 *
* 24 * 0 *
* 27 * 0 *
* 55 *
* 56 *
* 58 * <Speak_to_Record_Voice_Message>
* 72 *
* 103 *
```

For a full comprehensive list of programming codes, reference the Installation & Operation Manual for Emergency/Information Phones.

NOTE: The hash or # appended after the <Phone_Number> (i.e. for the * 13 * <Phone_Number> # * code) is only required if the Intelli-Voice option (V-Chip) is used on the ETP-400 Series Phone.

THIS PAGE IS INTENTIONALLY LEFT BLANK

THIS PAGE IS INTENTIONALLY LEFT BLANK

12

CCTV

Requirements



THIS SECTION IS TO BE PROVIDED AT A LATER DATE

THIS SECTION IS TO BE PROVIDED AT A LATER DATE

THIS SECTION IS TO BE PROVIDED AT A LATER DATE

THIS SECTION IS TO BE PROVIDED AT A LATER DATE

THIS PAGE IS INTENTIONALLY LEFT BLANK

13

Signage and Graphics



13. Signage, Graphics and Approved Color Palette

13.1. Introduction

Signage and graphic design should be developed to establish a visually distinctive and functional system to attract and communicate with those who commute and utilize the park & ride facility. It should create a lasting identity and provide way finding clarity. The intent is to provide flexibility while keeping with community standards. All sign square footages shall be calculated per face and are exclusive of the entry sign monument. Signage shall be reviewed and approved by SRTA and local governing codes and ordinances.

13.2. General Signage Criteria

Appropriate Permitted Sign Attributes

1. Minor Information and Directional signs shall have a maximum sign face of 35 square feet
2. Regulatory signs could be installed on a separate post or attached to an existing structure. The signs will include ornamental backing and frames.
3. Contrast is important for the legibility of signs. Light letters on a dark background or dark letters on a light background are most legible.
4. Limit the total number of colors used in any one sign. Small accents of several colors may make a sign unique and attractive, but the competition between large areas of many different colors decreases readability.
5. Limit the number of lettering styles in order to increase legibility. A general rule to follow is to limit the number of different letter types to no more than two (2) for small signs and three (3) for large signs.
6. Sign colors shall complement the colors used on the structures and the project as a whole.
7. Freestanding or monument signs shall be placed in logical locations near the project's entrance drive.

Sign Illumination

1. Signs shall be illuminated by an indirect source of light; this is usually the best arrangement because the sign will appear to be better integrated with the building's architecture. Light fixtures attached to the front of the structure cast light on the sign and the face of the structure as well.
2. Individually illuminated letters shall be backlit.
3. All illuminated signs shall be designed to provide a high-quality appearance in both natural light during the day and in artificial light at night.

Internally Illuminated Signs

1. Internally illuminated signs are signs in which illumination is provided by an artificial source of light contained within the sign itself and the light is transmitted through the sign panel, letters, or logo.
2. Internally illuminated signs shall be designed to minimize the amount of light that is transmitted through the sign panel. The display of white light should be limited to the sign copy. If lighting the sign copy only is not an option, the display of internal illumination through the background can be controlled by limiting its size to a small percentage of the sign area, changing the shape of the sign to reduce the lighted surface area, using a dark color, using an opaque screen, or a combination of these features.
3. Electrical transformer boxes and raceways are required to be concealed from public view. If a raceway cannot be mounted internally behind the finished exterior wall, the exposed metal surfaces of the raceway shall be finished to match the background wall or integrated into the overall design of the sign.
4. If raceways are necessary, they shall be as thin and narrow as possible and shall never extend in width or height beyond the area of the sign's lettering or graphics.

Prohibited Attributes of Sign Illumination

1. Sign lighting shall be concentrated and focused on the sign area and not diffused over the building or property. Glare and undesirable illumination on adjacent properties or streets must be managed with the proper light fixtures and shields.
2. Bare bulb light fixtures such as flood and spotlights shall not be used for sign lighting. This type of light fixture has a low-quality appearance, creates glare and hot spots, and the bulb cannot be adequately screened.
3. Flashing signs are prohibited.
4. All electrical wiring required for the lighting shall be hidden or located in as unobtrusive a location as possible. Any visible conduit or wires shall be painted out to blend with the background.

Prohibited Attributes for All Signs

1. Paper and cloth signs are appropriate for interior temporary use only.
2. Location of directional signs shall not encroach on the public right-of-way.

City/County Signage

1. Sign poles within city limits shall be consolidated wherever possible to reduce visual clutter. For example, 'No Parking' signs shall be incorporated on pole-mounted street lights rather than on separate poles. Free-standing vehicular wayfinding signs will continue to be installed on the previously adopted standard poles.
2. Future pedestrian wayfinding signs shall either be added to the vehicular wayfinding poles or attached to street lights to reduce the total number of required poles.
3. Wherever separate sign poles are necessary, these sign poles (excluding those for vehicular wayfinding signs) shall be of steel construction with a black, powder coat finish. Only galvanized (inside and out) schedule 40 steel posts (2.375" O.D.) shall be used, and such posts must include a galvanized flat cap (color to match) welded to the post's top surface.
4. All signage shall follow GDOT regulations and wooden sign posts are unacceptable in all public streetscape areas. Signage shall conform to MUTCD and GDOT standard specifications for sheeting and poles.

Signage Materials

1. Metal (formed, etched, cast, engraved, and properly primed and painted or factory coated to protect against corrosion).
2. High-density pre-formed foam or similar material. New materials may be very appropriate if properly designed in a manner consistent with these standards and painted or otherwise finished to complement the architecture.
3. Sign materials shall be compatible with the design of the bus shelter and maintenance building facade.

13.3. Entry Monument Sign

The main entrance of each park & ride facility shall have one (1) monument sign. The sign shall include the Xpress logo, shall conform to standard dimensions, finishes, and colors for the user to have a sense of arrival to the facility and a recognizable branding logo. The sign shall approximately 8' in height and 12' wide and 2' thick. It shall be made of cast concrete wrapped in brushed aluminum. The Xpress logo and letters shall be CNC cut out of the brushed aluminum panel. Applied brushed aluminum letters identifying the name of the park & ride facility shall be firmly attached to the metal panel.

The sign shall be up lit and back lit internally behind the logo/letters on the brushed aluminum panel. The monument sign shall not be installed within sight triangles or clear zones to keep visibility clear as motorists enter and exit the property. Monument Signs shall follow the requirements outlined in the GDOT design manual for sight triangles, sight distances, and clear zones. Low plantings in front of and around the Monument sign shall be required to high light the sign without restricting the view to the sign. Refer to entry monument sign detail below for general sign dimensions and requirements. Entry monument sign footings shall be signed and sealed by a registered licensed structural engineer in the state of Georgia. Figure 13.31.

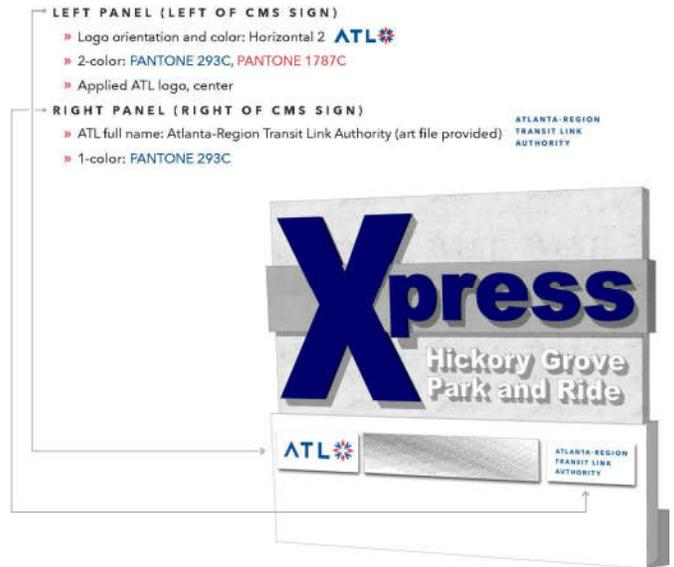

13



Figure 13.31 - Entry monument signage

Decorative Wayfinding / Regulatory Signage

Brandon Industries or approved equivalent
Phone: 800.247.1274
Website: <http://www.brandonindustries.com>

Description:

- Decorative breakaway pole and base.
- Black powder coat finish.
- Graphic/sign panel.
- Hardware (stainless steel).
- Color and finish: color shall be approved by SRTA.
- Regulatory signage shall conform to MUTCD and GDOT standards, requirements, and specifications.
- Install per manufacturer's recommendations.

Alternate Wayfinding/Regulatory Signage Manufacturer:

- Special Lite Products Company, Inc., 800.365.0511, same as specified above
- Capital Streetscapes, 855.339.7800, same as specified above

SP3X10 - 3" X 10" FLUTED POLE EXTRUDED ALUMINUM .125 WALL THICKNESS	
2PC-3 - BASE (BREAKAWAY) FOR 3" POLE CAST ALUMINUM	
FIN-B3 - BALL FINIAL FOR 3" POLE CAST ALUMINUM	
TS1218 - TRIM FOR 12"X18" TRAFFIC SIGN CAST ALUMINUM	
TS1206 - TRIM FOR 12"X6" TRAFFIC SIGN CAST ALUMINUM	
R7-8/12 RESERVED PARKING SIGN HI-INTENSITY, REFLECTIVE VINYL 12"X18" .080 ALUMINUM BLACK BACK	
R7-8A VAN ACCESSIBLE SIGN HI-INTENSITY, REFLECTIVE VINYL 12"X6" .080 ALUMINUM BLACK BACK	



REGULATORY SIGNAGE

MANUFACTURER:
 Brandon Industries
 1601 Wilmeth Road
 McKinney, TX 75069

MODEL NO.:
 SP3x12 - 3" x12" Fluted pole
 SB-33 - Slipover base
 FIN-B3 - Ball finial for HC post
 FIN-A3 - Acorn finial
 TS1218 - Trim
 TSTOP30 - Trim
 R7 - 8/12 - Reflective 12"x18"
 reserved parking sign
 R1-1/30 - Reflective 30" stop sign

DESCRIPTION:
 Pole and sign trim components to be aluminum, stainless steel fasteners, and black finish. Sign panel to be reflective with vinyl type.

THIS SIGN MADE FROM THE PARTS BELOW:

SP3X12 - 3" X 12" Fluted pole Extruded Aluminum .0125 Wall Thickness	
SB-33 - Slipover Base For 3" Pole Cast Aluminum	
FIN-A3 - Acorn Finial For 3" Pole Cast Aluminum	
TSTOP30 - Trim For 30" Stop Sign Cast Aluminum	
R1-1/30 Reflective 30" Stop Sign Specify Vinyl Type	

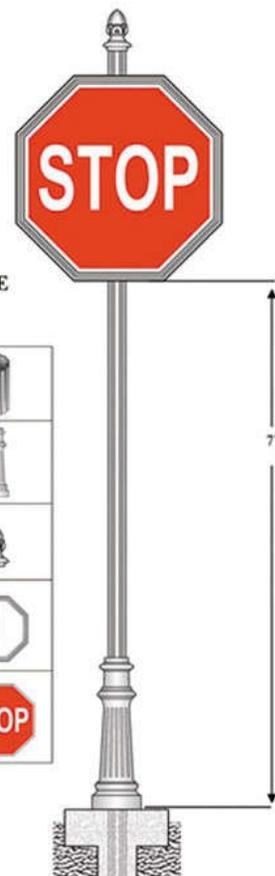

13.4. Approved Color Palette

Blue is an essential part of the SRTA visual identity. It's synonymous with being trustworthy, dependable, and secure. Combined with shades of gray and white, the palette provides a welcoming feeling that's easy to read, clean, and simple. When developing the design for future facilities the standard SRTA color palette shall be used and coordinated with site elements. The use of accent colors to add individual station identity and draw attention to priority elements will be considered. The use of accent colors shall be done sparingly. A color palette graphic shall be generated for each facility indicating all colors and materials proposed. This graphic shall be reviewed and approved by the owner prior to the completion of the design process. Color samples and material samples shall also be submitted to the owner or their representative by the contractor for final approval prior to purchase and installation of any on-site materials.

	SILVER METALLIC
	DARK BLUE METALLIC
	LIGHT BLUE METALLIC

Figure 13.41 - SRTA Express standard color palette

Typically, site furnishings will have a silver metallic or stainless steel color finish or a gloss black powder-coated finish.

Pavers or colored concrete shall be medium to dark gray/silver color tones or as a mix. Refer to figure 13.42.



Charcoal
(Pavestone)



Chicago Blend
(Pavestone)



Pewter
(Pavestone)

Figure 13.42 - Concrete paver approved colors

14

Specifications

(All other specifications and special provisions that are not in this section shall conform to Georgia Department of Transportation (GDOT) Standard Specifications Construction of Transportation Systems, 2013 Edition)



State Road and Tollway Authority (SRTA), State of Georgia

SPECIAL PROVISION

Section 763 – Bus Pavilion and/or Section 999 – Architectural Construction Maintenance Building

Section 033000 – Cast-In-Place Concrete

PART 1 - GENERAL

1.01 SUMMARY

- A. Section includes cast-in-place concrete, including formwork, vapor barrier, reinforcement, concrete materials, mixture design, placement procedures, and finishes.

1.02 DEFINITIONS

- A. Cementitious Materials: Portland cement alone or in combination with one or more of the following: blended hydraulic cement, fly ash, slag cement, other pozzolans, and silica fume; materials subject to compliance with requirements.
- B. W/C Ratio: The ratio by weight of water to cementitious materials.

1.03 ACTION SUBMITTALS

- A. Product Data: For each type of product.
- B. Sustainable Design Submittals: Refer to Section 018113 - Sustainable Design Requirements for requirements to attain LEED Certification required by this Section.
- C. Design Mixtures: For each concrete mixture. Submit alternate design mixtures when characteristics of materials, Project conditions, weather, test results, or other circumstances warrant adjustments.
 1. Indicate amounts of mixing water to be withheld for later addition at Project site.
- D. Steel Reinforcement Shop Drawings: Placing Drawings that detail fabrication, bending, and placement. Include bar sizes, lengths, material, grade, bar schedules, stirrup spacing, bent bar diagrams, bar arrangement, splices and laps, mechanical connections, tie spacing, hoop spacing, and supports for concrete reinforcement.
- E. Construction Joint Layout: Indicate proposed construction joints required to construct the structure.
 1. Location of construction joints is subject to approval of the Architect/Engineer.

- F. Samples: For vapor retarder.

1.04 INFORMATIONAL SUBMITTALS

- A. Welding certificates.
- B. Material Certificates: For each of the following, signed by manufacturers:
 1. Cementitious materials.
 2. Admixtures.
 3. Form materials and form-release agents.
 4. Steel reinforcement and accessories.
 5. Fiber reinforcement.
 6. Curing compounds.
 7. Floor and slab treatments.
 8. Bonding agents.
 9. Adhesives.
 10. Vapor retarders.
 11. Semirigid joint filler.
 12. Joint-filler strips.
 13. Repair materials.
- C. Material Test Reports: For the following, from a qualified testing agency:
 1. Aggregates: Include service record data indicating absence of deleterious expansion of concrete due to alkali aggregate reactivity.
- D. Floor surface flatness and levelness measurements indicating compliance with specified tolerances.
- E. Field quality-control reports.
- F. Minutes of preinstallation conference.

1.05 QUALITY ASSURANCE

- A. Manufacturer Qualifications: A firm experienced in manufacturing ready-mixed concrete products and that complies with ASTM C 94/C 94M requirements for production facilities and equipment.
 1. Manufacturer certified according to NRMCA's "Certification of Ready Mixed Concrete Production Facilities."
- B. Testing Agency Qualifications: An independent agency, acceptable to authorities having jurisdiction, qualified according to ASTM C 1077 and ASTM E 329 for testing indicated.
- C. Welding Qualifications: Qualify procedures and personnel according to AWS D1.4/D 1.4M.

1.06 FIELD CONDITIONS

- A. **Cold-Weather Placement:** Comply with ACI 306.1 and as follows. Protect concrete work from physical damage or reduced strength that could be caused by frost, freezing actions, or low temperatures.
1. When average high and low temperature is expected to fall below 40 deg F (4.4 deg C) for three successive days, maintain delivered concrete mixture temperature within the temperature range required by ACI 301 (ACI 301M).
 2. Do not use frozen materials or materials containing ice or snow. Do not place concrete on frozen subgrade or on subgrade containing frozen materials.
 3. Do not use calcium chloride, salt, or other materials containing antifreeze agents or chemical accelerators unless otherwise specified and approved in mixture designs.
- B. **Hot-Weather Placement:** Comply with ACI 301 (ACI 301M) and as follows:
1. Maintain concrete temperature below 90 deg F (32 deg C) at time of placement. Chilled mixing water or chopped ice may be used to control temperature, provided water equivalent of ice is calculated to total amount of mixing water. Using liquid nitrogen to cool concrete is Contractor's option.
 2. Fog-spray forms, steel reinforcement, and subgrade just before placing concrete. Keep subgrade uniformly moist without standing water, soft spots, or dry areas.

PART 2 - PRODUCTS

2.01 CONCRETE, GENERAL

- A. **ACI Publications:** Comply with the following unless modified by requirements in the Contract Documents:
1. ACI 301 (ACI 301M).
 2. ACI 117 (ACI 117M).

2.02 FORM-FACING MATERIALS

- A. **Smooth-Formed Finished Concrete:** Form-facing panels that provide continuous, true, and smooth concrete surfaces. Furnish in largest practicable sizes to minimize number of joints.
1. Plywood, metal, or other approved panel materials.
 2. Exterior-grade plywood panels, suitable for concrete forms, complying with DOC PS 1, and as follows:
 - a. High-density overlay, Class 1 or better.
 - b. Medium-density overlay, Class 1 or better; mill-release agent treated and edge sealed.
 - c. Structural 1, B-B or better; mill oiled and edge sealed.
 - d. B-B (Concrete Form), Class 1 or better; mill oiled and edge sealed.
 3. Overlaid Finnish birch plywood.
- B. **Rough-Formed Finished Concrete:** Plywood, lumber, metal, or another approved material. Provide lumber dressed on at least two edges and one side for tight fit.

- C. Chamfer Strips: Wood, metal, PVC, or rubber strips, 3/4 by 3/4 inch (19 by 19 mm), minimum.
- D. Form-Release Agent: Commercially formulated form-release agent that does not bond with, stain, or adversely affect concrete surfaces and does not impair subsequent treatments of concrete surfaces.
 - 1. Formulate form-release agent with rust inhibitor for steel form-facing materials.
- E. Form Ties: Factory-fabricated, removable or snap-off glass-fiber-reinforced plastic or metal form ties designed to resist lateral pressure of fresh concrete on forms and to prevent spalling of concrete on removal.
 - 1. Furnish units that leave no corrodible metal closer than 1 inch (25 mm) to the plane of exposed concrete surface.
 - 2. Furnish ties that, when removed, leave holes no larger than 1 inch (25 mm) in diameter in concrete surface.
 - 3. Furnish ties with integral water-barrier plates to walls indicated to receive dampproofing or waterproofing.

2.03 STEEL REINFORCEMENT

- A. Reinforcing Bars: ASTM A 615/A 615M, Grade 60 (Grade 420), deformed.
- B. Plain-Steel Wire: ASTM A 1064/A 1064M, galvanized.
- C. Deformed-Steel Wire: ASTM A 1064/A 1064M.
- D. Plain-Steel Welded-Wire Reinforcement: ASTM A 1064/A 1064M, plain, fabricated from as-drawn steel wire into flat sheets.
- E. Deformed-Steel Welded-Wire Reinforcement: ASTM A 1064/A 1064M, flat sheet.

2.04 REINFORCEMENT ACCESSORIES

- A. Joint Dowel Bars: ASTM A 615/A 615M, Grade 60 (Grade 420), plain-steel bars, cut true to length with ends square and free of burrs.
- B. Bar Supports: Bolsters, chairs, spacers, and other devices for spacing, supporting, and fastening reinforcing bars and welded-wire reinforcement in place. Manufacture bar supports from steel wire, plastic, or precast concrete according to CRSI's "Manual of Standard Practice," of greater compressive strength than concrete and as follows:
 - 1. For concrete surfaces exposed to view, where legs of wire bar supports contact forms, use CRSI Class 1 plastic-protected steel wire or CRSI Class 2 stainless-steel bar supports.
 - 2. For epoxy-coated reinforcement, use epoxy-coated or other dielectric-polymer-coated wire bar supports.
 - 3. For zinc-coated reinforcement, use galvanized wire or dielectric-polymer-coated wire bar supports.

2.05 CONCRETE MATERIALS

- A. Source Limitations: Obtain each type or class of cementitious material of the same brand from the same manufacturer's plant, obtain aggregate from single source, and obtain admixtures from single source from single manufacturer.
- B. Cementitious Materials:
1. Portland Cement: ASTM C 150/C 150M, Type III, gray.
 2. Fly Ash: ASTM C 618, Class F or C.
 3. Slag Cement: ASTM C 989/C 989M, Grade 100 or 120.
 4. Blended Hydraulic Cement: ASTM C 595/C 595M, Type IS, portland blast-furnace slag cement.
 5. Silica Fume: ASTM C 1240, amorphous silica.
- C. Normal-Weight Aggregates: ASTM C 33/C 33M, coarse aggregate or better, graded. Provide aggregates from a single source with documented service record data of at least 10 years' satisfactory service in similar applications and service conditions using similar aggregates and cementitious materials.
1. Maximum Coarse-Aggregate Size: 1-1/2 inches (38 mm) nominal.
 2. Fine Aggregate: Free of materials with deleterious reactivity to alkali in cement.
- D. Lightweight Aggregate: ASTM C 330/C 330M, 3/4-inch (19-mm) nominal maximum aggregate size.
- E. Air-Entraining Admixture: ASTM C 260/C 260M.
- F. Chemical Admixtures: Certified by manufacturer to be compatible with other admixtures and that do not contribute water-soluble chloride ions exceeding those permitted in hardened concrete. Do not use calcium chloride or admixtures containing calcium chloride.
1. Water-Reducing Admixture: ASTM C 494/C 494M, Type A.
 2. Retarding Admixture: ASTM C 494/C 494M, Type B.
 3. Water-Reducing and Retarding Admixture: ASTM C 494/C 494M, Type D.
 4. High-Range, Water-Reducing Admixture: ASTM C 494/C 494M, Type F.
 5. High-Range, Water-Reducing and Retarding Admixture: ASTM C 494/C 494M, Type G.
 6. Plasticizing and Retarding Admixture: ASTM C 1017/C 1017M, Type II.
- G. Set-Accelerating Corrosion-Inhibiting Admixture: Commercially formulated, anodic inhibitor or mixed cathodic and anodic inhibitor; capable of forming a protective barrier and minimizing chloride reactions with steel reinforcement in concrete and complying with ASTM C 494/C 494M, Type C.
- H. Non-Set-Accelerating Corrosion-Inhibiting Admixture: Commercially formulated, non-set-accelerating, anodic inhibitor or mixed cathodic and anodic inhibitor; capable of forming a protective barrier and minimizing chloride reactions with steel reinforcement in concrete.
- I. Color Pigment: ASTM C 979/C 979M, synthetic mineral-oxide pigments or colored water-reducing admixtures; color stable,[free of carbon black,] nonfading, and resistant to lime and other alkalis.
1. Color: As selected by Architect from manufacturer's full range.
- J. Water: ASTM C 94/C 94M.

2.06 VAPOR RETARDER

- A. Sheet Vapor Retarder: Petroleum vapor resistant, ASTM E 1745, Class A. Include manufacturer's recommended adhesive or pressure-sensitive tape.

2.07 CURING MATERIALS

- 2.08 Clear, Waterborne, Membrane-Forming Curing and Sealing Compound: ASTM C 1315, Type 1, Class A, certified by curing compound manufacturer to not interfere with bonding of floor covering and not exceeding 100g/L VOC content.

2.09 RELATED MATERIALS

- A. Expansion- and Isolation-Joint-Filler Strips: ASTM D 1751, asphalt-saturated cellulosic fiber for exterior joints, ASTM D 1752, cork or self-expanding cork for interior joints.
- B. Semirigid Joint Filler: Two-component, semirigid, 100 percent solids, epoxy resin with a Type A shore durometer hardness of 80 according to ASTM D 2240.
- C. Bonding Agent: ASTM C 1059/C 1059M, Type II, nonredispersible, acrylic emulsion or styrene butadiene.
- D. Epoxy Bonding Adhesive: ASTM C 881, two-component epoxy resin, capable of humid curing and bonding to damp surfaces, of class suitable for application temperature and of grade to suit requirements, and as follows:
 1. Types IV and V, load bearing, for bonding hardened or freshly mixed concrete to hardened concrete.

2.010 REPAIR MATERIALS

- A. Repair Underlayment: Cement-based, polymer-modified, self-leveling product that can be applied in thicknesses from 1/8 inch (3.2 mm) and that can be feathered at edges to match adjacent floor elevations.
 1. Cement Binder: ASTM C 150/C 150M, portland cement or hydraulic or blended hydraulic cement as defined in ASTM C 219.
 2. Primer: Product of underlayment manufacturer recommended for substrate, conditions, and application.
 3. Aggregate: Well-graded, washed gravel, 1/8 to 1/4 inch (3.2 to 6 mm) or coarse sand as recommended by underlayment manufacturer.
 4. Compressive Strength: Not less than 4100 psi (29 MPa) at 28 days when tested according to ASTM C 109/C 109M.
- B. Repair Overlayment: Cement-based, polymer-modified, self-leveling product that can be applied in thicknesses from 1/4 inch (6.4 mm) and that can be filled in over a scarified surface to match adjacent floor elevations.
 1. Cement Binder: ASTM C 150/C 150M, portland cement or hydraulic or blended hydraulic cement as defined in ASTM C 219.

2. **Primer:** Product of topping manufacturer recommended for substrate, conditions, and application.
3. **Aggregate:** Well-graded, washed gravel, 1/8 to 1/4 inch (3.2 to 6 mm) or coarse sand as recommended by topping manufacturer.
4. **Compressive Strength:** Not less than 4000 psi (34.5 MPa) at 28 days when tested according to ASTM C 109/C 109M.

2.011 CONCRETE MIXTURES, GENERAL

- A. **Prepare design mixtures for each type and strength of concrete, proportioned on the basis of laboratory trial mixture or field test data, or both, according to ACI 301 (ACI 301M).**
 1. Use a qualified independent testing agency for preparing and reporting proposed mixture designs based on laboratory trial mixtures.
- B. **Cementitious Materials: Limit percentage, by weight, of cementitious materials other than portland cement in concrete as follows:**
 1. Fly Ash: 25 percent.
 2. Combined Fly Ash and Pozzolan: 25 percent.
 3. Slag Cement: 50 percent.
 4. Combined Fly Ash or Pozzolan and Slag Cement: 50 percent portland cement minimum, with fly ash or pozzolan not exceeding 25 percent.
 5. Silica Fume: 10 percent.
 6. Combined Fly Ash, Pozzolan, and Silica Fume: 35 percent with fly ash or pozzolans not exceeding 25 percent and silica fume not exceeding 10 percent.
 7. Combined Fly Ash or Pozzolans, Slag Cement, and Silica Fume: 50 percent with fly ash or pozzolans not exceeding 25 percent and silica fume not exceeding 10 percent.
- C. **Limit water-soluble, chloride-ion content in hardened concrete to 0.30 percent by weight of cement;**
- D. **Admixtures: Use admixtures according to manufacturer's written instructions.**
 1. Use high-range water-reducing or plasticizing admixture in concrete, as required, for placement and workability.
 2. Use water-reducing and -retarding admixture when required by high temperatures, low humidity, or other adverse placement conditions.
 3. Use water-reducing admixture in pumped concrete, concrete for heavy-use industrial slabs and parking structure slabs, concrete required to be watertight, and concrete with a w/c ratio below 0.50.
 4. Use corrosion-inhibiting admixture in concrete mixtures where indicated.
- E. **Color Pigment: Add color pigment to concrete mixture according to manufacturer's written instructions and to result in hardened concrete color consistent with approved mockup.**

2.012 CONCRETE MIXTURES FOR BUILDING ELEMENTS

- A. **Footings & Foundation Walls:** Normal-weight concrete.
 1. Minimum Compressive Strength: 4000 psi (27.6 MPa) at 28 days.
 2. Maximum W/C Ratio: 0.45.

3. Slump Limit: 8 inches (200 mm) for concrete with verified slump of 2 to 4 inches (50 to 100 mm) before adding high-range water-reducing admixture or plasticizing admixture, plus or minus 1 inch (25 mm).
4. Air Content: 5.5 percent, plus or minus 1.5 percent at point of delivery for 1-1/2-inch (38-mm) nominal maximum aggregate size.
5. Air Content: 6 percent, plus or minus 1.5 percent at point of delivery for 3/4-inch (19-mm) nominal maximum aggregate size.

2.013

A. Slabs-on-Grade: Normal-weight concrete.

1. Minimum Compressive Strength: 4000 psi (27.6 MPa) at 28 days.
2. Maximum W/C Ratio: 0.45.
3. Minimum Cementitious Materials Content: 520 lb/cu. yd. (309 kg/cu. m).
4. Slump Limit: 4 inches (100 mm), plus or minus 1 inch (25 mm).
5. Air Content: 5.5 percent, plus or minus 1.5 percent at point of delivery for 1-1/2-inch (38-mm) nominal maximum aggregate size.
6. Air Content: 6 percent, plus or minus 1.5 percent at point of delivery for 3/4-inch (19-mm) nominal maximum aggregate size.
7. Air Content: Do not allow air content of trowel-finished floors to exceed 3 percent.

B. Concrete Toppings: Normal-weight concrete.

1. Minimum Compressive Strength: 3000 psi (20.7 MPa) at 28 days.
2. Minimum Cementitious Materials Content: 520 lb/cu. yd. (309 kg/cu. m).
3. Slump Limit: 4 inches (100 mm), plus or minus 1 inch (25 mm).
4. Air Content: 5.5 percent, plus or minus 1.5 percent at point of delivery for 1-1/2-inch (38-mm) nominal maximum aggregate size.
5. Air Content: 6 percent, plus or minus 1.5 percent at point of delivery for 3/4-inch (19-mm) nominal maximum aggregate size.
6. Air Content: Do not allow air content of trowel-finished toppings to exceed 3 percent.

2.014 FABRICATING REINFORCEMENT

A. Fabricate steel reinforcement according to CRSI's "Manual of Standard Practice."

2.015 CONCRETE MIXING

A. Ready-Mixed Concrete: Measure, batch, mix, and deliver concrete according to ASTM C 94/C 94M and ASTM C 1116/C 1116M, and furnish batch ticket information.

1. When air temperature is between 85 and 90 deg F (30 and 32 deg C), reduce mixing and delivery time from 1-1/2 hours to 75 minutes; when air temperature is above 90 deg F (32 deg C), reduce mixing and delivery time to 60 minutes.

B. Project-Site Mixing: Measure, batch, and mix concrete materials and concrete according to ASTM C 94/C 94M. Mix concrete materials in appropriate drum-type batch machine mixer.

1. For mixer capacity of 1 cu. yd. (0.76 cu. m) or smaller, continue mixing at least 1-1/2 minutes, but not more than 5 minutes after ingredients are in mixer, before any part of batch is released.

2. For mixer capacity larger than 1 cu. yd. (0.76 cu. m), increase mixing time by 15 seconds for each additional 1 cu. yd. (0.76 cu. m).
3. Provide batch ticket for each batch discharged and used in the Work, indicating Project identification name and number, date, mixture type, mixture time, quantity, and amount of water added. Record approximate location of final deposit in structure.

PART 3 - EXECUTION

3.01 FORMWORK INSTALLATION

- A. Design, erect, shore, brace, and maintain formwork, according to ACI 301 (ACI 301M), to support vertical, lateral, static, and dynamic loads, and construction loads that might be applied, until structure can support such loads.
- B. Construct formwork so concrete members and structures are of size, shape, alignment, elevation, and position indicated, within tolerance limits of ACI 117 (ACI 117M).
- C. Limit concrete surface irregularities, designated by ACI 347 as abrupt or gradual, as follows:
 1. Class A, 1/8 inch (3.2 mm) for smooth-formed finished surfaces.
 2. Class B, 1/4 inch (6 mm) for rough-formed finished surfaces.
- D. Construct forms tight enough to prevent loss of concrete mortar.
- E. Construct forms for easy removal without hammering or prying against concrete surfaces. Provide crush or wrecking plates where stripping may damage cast-concrete surfaces. Provide top forms for inclined surfaces steeper than 1.5 horizontal to 1 vertical.
 1. Install keyways, recesses, and the like, for easy removal.
 2. Do not use rust-stained steel form-facing material.
- F. Set edge forms, bulkheads, and intermediate screed strips for slabs to achieve required elevations and slopes in finished concrete surfaces. Provide and secure units to support screed strips; use strike-off templates or compacting-type screeds.
- G. Provide temporary openings for cleanouts and inspection ports where interior area of formwork is inaccessible. Close openings with panels tightly fitted to forms and securely braced to prevent loss of concrete mortar. Locate temporary openings in forms at inconspicuous locations.
- H. Chamfer exterior corners and edges of permanently exposed concrete.
- I. Form openings, chases, offsets, sinkages, keyways, blocking, screeds, and bulkheads required in the Work. Determine sizes and locations from trades providing such items.
- J. Clean forms and adjacent surfaces to receive concrete. Remove chips, wood, sawdust, dirt, and other debris just before placing concrete.
- K. Retighten forms and bracing before placing concrete, as required, to prevent mortar leaks and maintain proper alignment.
- L. Coat contact surfaces of forms with form-release agent, according to manufacturer's written instructions, before placing reinforcement.

3.02 EMBEDDED ITEM INSTALLATION

- A. Place and secure anchorage devices and other embedded items required for adjoining work that is attached to or supported by cast-in-place concrete. Use setting drawings, templates, diagrams, instructions, and directions furnished with items to be embedded.
 1. Install anchor rods, accurately located, to elevations required and complying with tolerances in Section 7.5 of AISC 303.

3.03 REMOVING AND REUSING FORMS

- A. General: Formwork for sides of the Work that does not support weight of concrete may be removed after cumulatively curing at not less than 50 deg F (10 deg C) for 24 hours after placing concrete. Concrete has to be hard enough to not be damaged by form-removal operations, and curing and protection operations need to be maintained.
 1. Leave formwork for that support weight of concrete in place until concrete has achieved at least 80 percent of its 28-day design compressive strength.
 2. Remove forms only if shores have been arranged to permit removal of forms without loosening or disturbing shores.
- B. Clean and repair surfaces of forms to be reused in the Work. Split, frayed, delaminated, or otherwise damaged form-facing material are not acceptable for exposed surfaces. Apply new form-release agent.
- C. When forms are reused, clean surfaces, remove fins and laitance, and tighten to close joints. Align and secure joints to avoid offsets. Do not use patched forms for exposed concrete surfaces unless approved by Architect.

3.04 SHORING AND RESHORING INSTALLATION

- A. Comply with ACI 318 (ACI 318M) and ACI 301 (ACI 301M) for design, installation, and removal of shoring and reshoring.
 1. Do not remove shoring or reshoring until measurement of slab tolerances is complete.

3.05 VAPOR-RETARDER INSTALLATION

- A. Sheet Vapor Retarders: Place, protect, and repair sheet vapor retarder according to ASTM E 1643 and manufacturer's written instructions.
 1. Lap joints 6 inches (150 mm) and seal with manufacturer's recommended tape.

3.06 STEEL REINFORCEMENT INSTALLATION

- A. General: Comply with CRSI's "Manual of Standard Practice" for fabricating, placing, and supporting reinforcement.
 1. Do not cut or puncture vapor retarder. Repair damage and reseal vapor retarder before placing concrete.

- B. Clean reinforcement of loose rust and mill scale, earth, ice, and other foreign materials that reduce bond to concrete.
- C. Accurately position, support, and secure reinforcement against displacement. Locate and support reinforcement with bar supports to maintain minimum concrete cover. Do not tack weld crossing reinforcing bars.
 - 1. Weld reinforcing bars according to AWS D1.4/D 1.4M, where indicated.
- D. Set wire ties with ends directed into concrete, not toward exposed concrete surfaces.
- E. Install welded-wire reinforcement in longest practicable lengths on bar supports spaced to minimize sagging. Lap edges and ends of adjoining sheets at least one mesh spacing. Offset laps of adjoining sheet widths to prevent continuous laps in either direction. Lace overlaps with wire.
- F. Tape punctures through vapor barrier vapor tight.

3.07 JOINTS

- A. General: Construct joints true to line with faces perpendicular to surface plane of concrete.
- B. Construction Joints: Install so strength and appearance of concrete are not impaired, at locations indicated or as approved by *Architect/Engineer*.
 - 1. Place joints perpendicular to main reinforcement. Continue reinforcement across construction joints unless otherwise indicated. Do not continue reinforcement through sides of strip placements of floors and slabs.
 - 2. Form keyed joints as indicated. Embed keys at least 1-1/2 inches (38 mm) into concrete.
 - 3. Locate joints for beams, slabs, joists, and girders in the middle third of spans. Offset joints in girders a minimum distance of twice the beam width from a beam-girder intersection.
 - 4. Locate horizontal joints in walls and columns at underside of floors, slabs, beams, and girders and at the top of footings or floor slabs.
 - 5. Space vertical joints in walls as indicated. Locate joints beside piers integral with walls, near corners, and in concealed locations where possible.
 - 6. Use a bonding agent at locations where fresh concrete is placed against hardened or partially hardened concrete surfaces.
 - 7. Use epoxy-bonding adhesive at locations where fresh concrete is placed against hardened or partially hardened concrete surfaces.
- C. Contraction Joints in Slabs-on-Grade: Form weakened-plane contraction joints, sectioning concrete into areas as indicated. Construct contraction joints for a depth equal to at least one-fourth of concrete thickness as follows:
 - 1. Grooved Joints: Form contraction joints after initial floating by grooving and finishing each edge of joint to a radius of 1/8 inch (3.2 mm). Repeat grooving of contraction joints after applying surface finishes. Eliminate groover tool marks on concrete surfaces.
 - 2. Sawed Joints: Form contraction joints with power saws equipped with shatterproof abrasive or diamond-rimmed blades. Cut 1/8-inch- (3.2-mm-) wide joints into concrete when cutting action does not tear, abrade, or otherwise damage surface and before concrete develops random contraction cracks.

- D. **Isolation Joints in Slabs-on-Grade:** After removing formwork, install joint-filler strips at slab junctions with vertical surfaces, such as column pedestals, foundation walls, grade beams, and other locations, as indicated.
1. Extend joint-filler strips full width and depth of joint, terminating flush with finished concrete surface unless otherwise indicated.
 2. Terminate full-width joint-filler strips not less than 1/2 inch (13 mm) or more than 1 inch (25 mm) below finished concrete surface where joint sealants, specified in Section 079200 "Joint Sealants," are indicated.
 3. Install joint-filler strips in lengths as long as practicable. Where more than one length is required, lace or clip sections together.
- E. **Doweled Joints:** Install dowel bars and support assemblies at joints where indicated. Lubricate or asphalt coat one-half of dowel length to prevent concrete bonding to one side of joint.

3.08 CONCRETE PLACEMENT

- A. Before placing concrete, verify that installation of formwork, reinforcement, and embedded items is complete and that required inspections are completed.
- B. Before test sampling and placing concrete, water may be added at Project site, subject to limitations of ACI 301 (ACI 301M).
1. Do not add water to concrete after adding high-range water-reducing admixtures to mixture.
- C. Deposit concrete continuously in one layer or in horizontal layers of such thickness that no new concrete is placed on concrete that has hardened enough to cause seams or planes of weakness. If a section cannot be placed continuously, provide construction joints as indicated. Deposit concrete to avoid segregation.
1. Deposit concrete in horizontal layers of depth not to exceed formwork design pressures and in a manner to avoid inclined construction joints.
 2. Consolidate placed concrete with mechanical vibrating equipment according to ACI 301 (ACI 301M).
 3. Do not use vibrators to transport concrete inside forms. Insert and withdraw vibrators vertically at uniformly spaced locations to rapidly penetrate placed layer and at least 6 inches (150 mm) into preceding layer. Do not insert vibrators into lower layers of concrete that have begun to lose plasticity. At each insertion, limit duration of vibration to time necessary to consolidate concrete and complete embedment of reinforcement and other embedded items without causing mixture constituents to segregate.
- D. Deposit and consolidate concrete for floors and slabs in a continuous operation, within limits of construction joints, until placement of a panel or section is complete.
1. Consolidate concrete during placement operations, so concrete is thoroughly worked around reinforcement and other embedded items and into corners.
 2. Maintain reinforcement in position on chairs during concrete placement.
 3. Screed slab surfaces with a straightedge and strike off to correct elevations.
 4. Slope surfaces uniformly to drains where required.
 5. Begin initial floating using bull floats or darbies to form a uniform and open-textured surface plane, before excess bleedwater appears on the surface. Do not further disturb slab surfaces before starting finishing operations.

3.09 FINISHING FORMED SURFACES

- A. **Rough-Formed Finish:** As-cast concrete texture imparted by form-facing material with tie holes and defects repaired and patched. Remove fins and other projections that exceed specified limits on formed-surface irregularities.
 - 1. Apply to concrete surfaces not exposed to public view.
- B. **Smooth-Formed Finish:** As-cast concrete texture imparted by form-facing material, arranged in an orderly and symmetrical manner with a minimum of seams. Repair and patch tie holes and defects. Remove fins and other projections that exceed specified limits on formed-surface irregularities.
 - 1. Apply to concrete surfaces exposed to public view,
- C. **Rubbed Finish:** Apply the following to smooth-formed-finished as-cast concrete where indicated:
 - 1. **Smooth-Rubbed Finish:** Not later than one day after form removal, moisten concrete surfaces and rub with carborundum brick or another abrasive until producing a uniform color and texture. Do not apply cement grout other than that created by the rubbing process.
- D. **Related Unformed Surfaces:** At tops of walls, horizontal offsets, and similar unformed surfaces adjacent to formed surfaces, strike off smooth and finish with a texture matching adjacent formed surfaces. Continue final surface treatment of formed surfaces uniformly across adjacent unformed surfaces unless otherwise indicated.

3.010 FINISHING FLOORS AND SLABS

- A. **General:** Comply with ACI 302.1R recommendations for screeding, restraighening, and finishing operations for concrete surfaces. Do not wet concrete surfaces.
- B. **Scratch Finish:** While still plastic, texture concrete surface that has been screeded and bull-floated or darbied. Use stiff brushes, brooms, or rakes to produce a profile amplitude of 1/4 inch (6 mm) in one direction.
 - 1. Apply scratch finish to surfaces to receive concrete floor toppings.
- C. **Float Finish:** Consolidate surface with power-driven floats or by hand floating if area is small or inaccessible to power-driven floats. Restraighten, cut down high spots, and fill low spots. Repeat float passes and restraighening until surface is left with a uniform, smooth, granular texture.
 - 1. Apply float finish to surfaces to receive trowel finish and to be covered with fluid-applied or sheet waterproofing, built-up or membrane roofing, or sand-bed terrazzo.
- D. **Trowel Finish:** After applying float finish, apply first troweling and consolidate concrete by hand or power-driven trowel. Continue troweling passes and restraighten until surface is free of trowel marks and uniform in texture and appearance. Grind smooth any surface defects that would telegraph through applied coatings or floor coverings.
 - 1. Apply a trowel finish to surfaces indicated.
 - 2. Finish surfaces to the following tolerances, according to ASTM E 1155 (ASTM E 1155M), for a randomly trafficked floor surface:

- a. Specified overall values of flatness, $F(F)$ 25; and of levelness, $F(L)$ 20; with minimum local values of flatness, $F(F)$ 17; and of levelness, $F(L)$ 15.
 - b. Specified overall values of flatness, $F(F)$ 35; and of levelness, $F(L)$ 25; with minimum local values of flatness, $F(F)$ 24; and of levelness, $F(L)$ 17; for slabs-on-grade.
3. Finish and measure surface, so gap at any point between concrete surface and an unlevelled, freestanding, 10-ft.- (3.05-m-) long straightedge resting on two high spots and placed anywhere on the surface does not exceed 1/8 inch (6 mm).
- E. Trowel and Fine-Broom Finish: Apply a first trowel finish to surfaces indicated. While concrete is still plastic, slightly scarify surface with a fine broom.
- 1. Comply with flatness and levelness tolerances for trowel-finished floor surfaces.
- F. Broom Finish: Apply a broom finish to exterior concrete slabs, platforms, steps, slopes, and elsewhere as indicated.
- 1. Immediately after float finishing, slightly roughen trafficked slab surface by brooming with fiber-bristle broom parallel to direction of drainage, and slightly roughen ramp and steps trafficked surface by brooming with fiber-bristle broom perpendicular to direction of traffic. Coordinate required final finish with Architect before application.

3.011 MISCELLANEOUS CONCRETE ITEM INSTALLATION

- A. Filling In: Fill in holes and openings left in concrete structures after work of other trades is in place unless otherwise indicated. Mix, place, and cure concrete, as specified, to blend with in-place construction. Provide other miscellaneous concrete filling indicated or required to complete the Work.
- B. Curbs: Provide monolithic finish to interior curbs by stripping forms while concrete is still green and by steel-troweling surfaces to a hard, dense finish with corners, intersections, and terminations slightly rounded.

3.012 CONCRETE PROTECTING AND CURING

- A. General: Protect freshly placed concrete from premature drying and excessive cold or hot temperatures. Comply with ACI 306.1 for cold-weather protection and ACI 301 (ACI 301M) for hot-weather protection during curing.
- B. Evaporation Retarder: Apply evaporation retarder to unformed concrete surfaces if hot, dry, or windy conditions cause moisture loss approaching 0.2 lb/sq. ft. x h (1 kg/sq. m x h) before and during finishing operations. Apply according to manufacturer's written instructions after placing, screeding, and bull floating or darbying concrete, but before float finishing.
- C. Formed Surfaces: Cure formed concrete surfaces. If forms remain during curing period, moist cure after loosening forms. If removing forms before end of curing period, continue curing for remainder of curing period.
- D. Unformed Surfaces: Begin curing immediately after finishing concrete. Cure unformed surfaces, including floors and slabs, concrete floor toppings, and other surfaces.
- E. Cure concrete according to ACI 308.1, by one or a combination of the following methods *below*.

1. **Moisture Curing:** Keep surfaces continuously moist for not less than seven days with the following materials:
 - a. Water.
 - b. Continuous water-fog spray.
 - c. Absorptive cover, water saturated, and kept continuously wet. Cover concrete surfaces and edges with 12-inch (300-mm) lap over adjacent absorptive covers.
2. **Moisture-Retaining-Cover Curing:** Cover concrete surfaces with moisture-retaining cover for curing concrete, placed in widest practicable width, with sides and ends lapped at least 12 inches (300 mm), and sealed by waterproof tape or adhesive. Cure for not less than seven days. Immediately repair any holes or tears during curing period, using cover material and waterproof tape.
 - a. Moisture cure or use moisture-retaining covers to cure concrete surfaces to receive floor coverings.
 - b. Moisture cure or use moisture-retaining covers to cure concrete surfaces to receive penetrating liquid floor treatments.
 - c. Cure concrete surfaces to receive floor coverings with either a moisture-retaining cover or a curing compound that the manufacturer certifies does not interfere with bonding of floor covering used on Project.
3. **Curing Compound:** Apply uniformly in continuous operation by power spray or roller according to manufacturer's written instructions. Recoat areas subjected to heavy rainfall within three hours after initial application. Maintain continuity of coating and repair damage during curing period.
 - a. **Removal:** After curing period has elapsed, remove curing compound without damaging concrete surfaces by method recommended by curing compound manufacturer unless manufacturer certifies curing compound does not interfere with bonding of floor covering used on Project.
4. **Curing and Sealing Compound:** For slabs not covered with resinous flooring, apply uniformly to floors and slabs indicated in a continuous operation by power spray or roller according to manufacturer's written instructions. Recoat areas subjected to heavy rainfall within three hours after initial application. Repeat process 24 hours later and apply a second coat. Maintain continuity of coating and repair damage during curing period.

3.013 CONCRETE SURFACE REPAIRS

- A. **Defective Concrete:** Repair and patch defective areas when approved by Architect. Remove and replace concrete that cannot be repaired and patched to Architect's approval.
- B. **Patching Mortar:** Mix dry-pack patching mortar, consisting of 1 part portland cement to 2-1/2 parts fine aggregate passing a No. 16 (1.18-mm) sieve, using only enough water for handling and placing.
- C. **Repairing Formed Surfaces:** Surface defects include color and texture irregularities, cracks, spalls, air bubbles, honeycombs, rock pockets, fins and other projections on the surface, and stains and other discolorations that cannot be removed by cleaning.
 1. Immediately after form removal, cut out honeycombs, rock pockets, and voids more than 1/2 inch (13 mm) in any dimension to solid concrete. Limit cut depth to 3/4 inch (19 mm). Make edges of cuts perpendicular to concrete surface. Clean, dampen with water, and

- brush-coat holes and voids with bonding agent. Fill and compact with patching mortar before bonding agent has dried. Fill form-tie voids with patching mortar or cone plugs secured in place with bonding agent.
2. Repair defects on surfaces exposed to view by blending white portland cement and standard portland cement so that, when dry, patching mortar matches surrounding color. Patch a test area at inconspicuous locations to verify mixture and color match before proceeding with patching. Compact mortar in place and strike off slightly higher than surrounding surface.
 3. Repair defects on concealed formed surfaces that affect concrete's durability and structural performance as determined by Architect.
- D. **Repairing Unformed Surfaces:** Test unformed surfaces, such as floors and slabs, for finish and verify surface tolerances specified for each surface. Correct low and high areas. Test surfaces sloped to drain for trueness of slope and smoothness; use a sloped template.
1. Repair finished surfaces containing defects. Surface defects include spalls, popouts, honeycombs, rock pockets, crazing and cracks in excess of 0.01 inch (0.25 mm) wide or that penetrate to reinforcement or completely through unreinforced sections regardless of width, and other objectionable conditions.
 2. After concrete has cured at least 14 days, correct high areas by grinding.
 3. Correct localized low areas during or immediately after completing surface finishing operations by cutting out low areas and replacing with patching mortar. Finish repaired areas to blend into adjacent concrete.
 4. Correct other low areas scheduled to receive floor coverings with a repair underlayment. Prepare, mix, and apply repair underlayment and primer according to manufacturer's written instructions to produce a smooth, uniform, plane, and level surface. Feather edges to match adjacent floor elevations.
 5. Correct other low areas scheduled to remain exposed with a repair topping. Cut out low areas to ensure a minimum repair topping depth of 1/4 inch (6 mm) to match adjacent floor elevations. Prepare, mix, and apply repair topping and primer according to manufacturer's written instructions to produce a smooth, uniform, plane, and level surface.
 6. Repair defective areas, except random cracks and single holes 1 inch (25 mm) or less in diameter, by cutting out and replacing with fresh concrete. Remove defective areas with clean, square cuts and expose steel reinforcement with at least a 3/4-inch (19-mm) clearance all around. Dampen concrete surfaces in contact with patching concrete and apply bonding agent. Mix patching concrete of same materials and mixture as original concrete, except without coarse aggregate. Place, compact, and finish to blend with adjacent finished concrete. Cure in same manner as adjacent concrete.
 7. Repair random cracks and single holes 1 inch (25 mm) or less in diameter with patching mortar. Groove top of cracks and cut out holes to sound concrete and clean off dust, dirt, and loose particles. Dampen cleaned concrete surfaces and apply bonding agent. Place patching mortar before bonding agent has dried. Compact patching mortar and finish to match adjacent concrete. Keep patched area continuously moist for at least 72 hours.
- E. Perform structural repairs of concrete, subject to Architect's approval, using epoxy adhesive and patching mortar.
- F. Repair materials and installation not specified above may be used, subject to Architect's approval.

3.014 FIELD QUALITY CONTROL

- A. **Special Inspections:** Owner will engage a [special inspector] [and] [qualified testing and inspecting agency] to perform field tests and inspections and prepare test reports.

- B. **Testing Agency:** Engage a qualified testing and inspecting agency to perform tests and inspections and to submit reports.
- C. **Inspections:**
1. Steel reinforcement placement.
 2. Steel reinforcement welding.
 3. Headed bolts and studs.
 4. Verification of use of required design mixture.
 5. Concrete placement, including conveying and depositing.
 6. Curing procedures and maintenance of curing temperature.
 7. Verification of concrete strength before removal of shores and forms from beams and slabs.
- D. **Concrete Tests:** Testing of composite samples of fresh concrete obtained according to ASTM C 172/C 172M shall be performed at the point of the pouring according to the following requirements:
1. **Testing Frequency:** Obtain one composite sample for each day's pour of each concrete mixture exceeding 5 cu. yd. (4 cu. m), but less than 25 cu. yd. (19 cu. m), plus one set for each additional 50 cu. yd. (38 cu. m) or fraction thereof.
 2. **Testing Frequency:** Obtain at least one composite sample for each 100 cu. yd. (76 cu. m) or fraction thereof of each concrete mixture placed each day.
 - a. When frequency of testing provides fewer than five compressive-strength tests for each concrete mixture, testing shall be conducted from at least five randomly selected batches or from each batch if fewer than five are used.
 3. **Slump:** ASTM C 143/C 143M; one test at point of placement for each composite sample, but not less than one test for each day's pour of each concrete mixture. Perform additional tests when concrete consistency appears to change.
 4. **Air Content:** ASTM C 231/C 231M, pressure method, for normal-weight concrete; ASTM C 173/C 173M, volumetric method, for structural lightweight concrete; one test for each composite sample, but not less than one test for each day's pour of each concrete mixture.
 5. **Concrete Temperature:** ASTM C 1064/C 1064M; one test hourly when air temperature is 40 deg F (4.4 deg C) and below or 80 deg F (27 deg C) and above, and one test for each composite sample.
 6. **Unit Weight:** ASTM C 567/C 567M, fresh unit weight of structural lightweight concrete; one test for each composite sample, but not less than one test for each day's pour of each concrete mixture.
 7. **Compression Test Specimens:** ASTM C 31/C 31M.
 - a. Cast and laboratory cure two sets of two standard cylinder specimens for each composite sample.
 - b. Cast and field cure two sets of two standard cylinder specimens for each composite sample.
 8. **Compressive-Strength Tests:** ASTM C 39/C 39M; test one set of two laboratory-cured specimens at 7 days and one set of two specimens at 28 days.
 - a. Test one set of two field-cured specimens at 7 days and one set of two specimens at 28 days.
 - b. A compressive-strength test shall be the average compressive strength from a set of two specimens obtained from same composite sample and tested at age indicated.

9. When strength of field-cured cylinders is less than 85 percent of companion laboratory-cured cylinders, Contractor shall evaluate operations and provide corrective procedures for protecting and curing in-place concrete.
 10. Strength of each concrete mixture will be satisfactory if every average of any three consecutive compressive-strength tests equals or exceeds specified compressive strength and no compressive-strength test value falls below specified compressive strength by more than 500 psi (3.4 MPa).
 11. Test results shall be reported in writing to Architect, concrete manufacturer, and Contractor within 48 hours of testing. Reports of compressive-strength tests shall contain Project identification name and number, date of concrete placement, name of concrete testing and inspecting agency, location of concrete batch in Work, design compressive strength at 28 days, concrete mixture proportions and materials, compressive breaking strength, and type of break for both 7- and 28-day tests.
 12. Nondestructive Testing: Impact hammer, sonoscope, or other nondestructive device may be permitted by Architect but will not be used as sole basis for approval or rejection of concrete.
 13. Additional Tests: Testing and inspecting agency shall make additional tests of concrete when test results indicate that slump, air entrainment, compressive strengths, or other requirements have not been met, as directed by Architect. Testing and inspecting agency may conduct tests to determine adequacy of concrete by cored cylinders complying with ASTM C 42/C 42M or by other methods as directed by Architect.
 14. Additional testing and inspecting, at Contractor's expense, will be performed to determine compliance of replaced or additional work with specified requirements.
 15. Correct deficiencies in the Work that test reports and inspections indicate do not comply with the Contract Documents.
- E. Measure floor and slab flatness and levelness according to ASTM E 1155 (ASTM E 1155M) within 24 to 48 hours of finishing.

3.015 PROTECTION OF RESINOUS COATED FLOORS

- A. Protect floors schedule to receive resinous coating from damage and wear during the remainder of construction period. Use protective methods and materials, including temporary hard covering, as recommended in writing by resinous flooring installer.

3.016 PAYMENT

- A. Lump sum price for Bus Pavilion and Architectural Construction Maintenance Building covers all items of work in this Special Provision including furnishing labor, materials, tools, equipment, and incidentals required to complete the work.

END OF SECTION

State Road and Tollway Authority (SRTA), State of Georgia

SPECIAL PROVISION

Section 999 – Architectural Construction Maintenance Building

Section 042200 – Concrete Unit Masonry

PART 1 - GENERAL

1.01 SUMMARY

A. Section Includes:

1. Concrete masonry units.
2. Decorative polished and ground faced concrete masonry units.
3. Pre-faced glazed concrete masonry units.
4. White exterior and grey interior exposed to view mortars.
5. Grout.
6. Steel reinforcing bars.
7. Masonry-joint reinforcement.
8. Embedded flashing.
9. Installation of cavity insulation.
10. Miscellaneous masonry accessories.

B. Products Installed but not Furnished under This Section:

1. Cast-stone trim in concrete unit masonry.
2. Conduit for electrical devices.

C. Related Requirements:

1. Section 051200 "Structural Steel Framing" for installing anchor sections of adjustable masonry anchors for connecting to structural steel frame.
2. Section 055000 "Metal Fabrications" for loose steel lintels.
3. Section 072100 "Thermal Insulation" for masonry wall insulation.
4. Section 076200 "Sheet Metal Flashing and Trim" for exposed sheet metal flashing and for furnishing manufactured reglets installed in masonry joints.

1.02 DEFINITIONS

- A. CMU(s): Concrete masonry unit(s).
- B. Reinforced Masonry: Masonry containing reinforcing steel in grouted cells.

1.03 PREINSTALLATION MEETINGS

- A. Preinstallation Conference: Conduct conference at Project site.

1.04 ACTION SUBMITTALS

- A. **Product Data:** For each type of product.
- B. **Sustainable Design Submittals:** Refer to Section 018113 - Sustainable Design Requirements for requirements to attain LEED Certification required by the Section.
- C. **Samples for Verification:** For each type and color of the following:
 - 1. Exposed Decorative CMUs.
 - 2. Pre-faced glazed CMUs.
 - 3. White and grey mortar samples.

1.05 INFORMATIONAL SUBMITTALS

- A. **Qualification Data:** For testing agency.
- B. **Material Certificates:** For each type and size of the following:
 - 1. Masonry units.
 - a. Include data on material properties and material test reports substantiating compliance with requirements.
 - b. For masonry units used in structural masonry] include data and calculations establishing average net-area compressive strength of units.
 - 2. Preblended, dry mortar mixes. Include description of type and proportions of ingredients.
 - 3. Grout mixes. Include description of type and proportions of ingredients.
 - 4. Reinforcing bars.
 - 5. Joint reinforcement.
 - 6. Anchors, ties, and metal accessories.
- C. **Mix Designs:** For each type of mortar and grout. Include description of type and proportions of ingredients.
 - 1. Include test reports for mortar mixes required to comply with property specification. Test according to ASTM C 109/C 109M for compressive strength, ASTM C 1506 for water retention, and ASTM C 91/C 91M for air content.
 - 2. Include test reports, according to ASTM C 1019, for grout mixes required to comply with compressive strength requirement.
- D. **Statement of Compressive Strength of Masonry:** For each combination of masonry unit type and mortar type, provide statement of average net-area compressive strength of masonry units, mortar type, and resulting net-area compressive strength of masonry determined according to TMS 602/ACI 530.1/ASCE 6.
- E. **Cold-Weather and Hot-Weather Procedures:** Detailed description of methods, materials, and equipment to be used to comply with requirements.

1.06 QUALITY ASSURANCE

- A. **Testing Agency Qualifications:** Qualified according to ASTM C 1093 for testing indicated.

- B. Mockup: Build mockup to verify selections made under Sample submittals, to demonstrate aesthetic effects, and to set quality standards for materials and execution. Coordinate with mockup of air barrier, storefront system and insulated metal wall panels.**
1. Build mockup of typical wall area as directed by Owner.
 2. Build mockups for each type of unit masonry construction in sizes approximately 60 inches (1500 mm) long by 72 inches (1800 mm) high by full thickness, including face and backup wythes and accessories.
 - a. Include a sealant-filled joint at least 16 inches (400 mm) long in exterior wall mockup.
 - b. Include lower corner of window opening at upper corner of exterior wall mockup. Make opening approximately 12 inches (300 mm) wide by 16 inches (400 mm) high.
 - c. Include through-wall flashing installed for a 24-inch (600-mm) length in corner of exterior wall mockup approximately 16 inches (400 mm) down from top of mockup, with a 12-inch (300-mm) length of flashing left exposed to view (omit masonry above half of flashing).
 3. Protect accepted mockups from the elements with weather-resistant membrane.
 4. Approval of mockups is for color, texture, and blending of masonry units; relationship of mortar and sealant colors to masonry unit colors; tooling of joints; and aesthetic qualities of workmanship.
 - a. Approval of mockups is also for other material and construction qualities specifically approved by Owner in writing.
 - b. Approval of mockups does not constitute approval of deviations from the Contract Documents contained in mockups unless Owner specifically approves such deviations in writing.
 5. Subject to compliance with requirements, approved mockups may become part of the completed Work if undisturbed at time of Substantial Completion.

1.07 DELIVERY, STORAGE, AND HANDLING

- A. Store masonry units on elevated platforms in a dry location. If units are not stored in an enclosed location, cover tops and sides of stacks with waterproof sheeting, securely tied. If units become wet, do not install until they are dry.
- B. Deliver preblended, dry mortar mix in moisture-resistant containers. Store preblended, dry mortar mix in delivery containers on elevated platforms in a dry location or in covered weatherproof dispensing silos.
- C. Store masonry accessories, including metal items, to prevent corrosion and accumulation of dirt and oil.

1.08 FIELD CONDITIONS

- A. Protection of Masonry: During construction, cover tops of walls, projections, and sills with waterproof sheeting at end of each day's work. Cover partially completed masonry when construction is not in progress.
 1. Extend cover a minimum of 24 inches (600 mm) down both sides of walls, and hold cover securely in place.

- B. Do not apply uniform floor or roof loads for at least 12 hours and concentrated loads for at least three days after building masonry walls or columns.
- C. Stain Prevention: Prevent grout, mortar, and soil from staining the face of masonry to be left exposed or painted. Immediately remove grout, mortar, and soil that come in contact with such masonry.
 - 1. Protect base of walls from rain-splashed mud and from mortar splatter by spreading coverings on ground and over wall surface.
 - 2. Protect sills, ledges, and projections from mortar droppings.
 - 3. Protect surfaces of window and door frames, as well as similar products with painted and integral finishes, from mortar droppings.
 - 4. Turn scaffold boards near the wall on edge at the end of each day to prevent rain from splashing mortar and dirt onto completed masonry.
- D. Cold-Weather Requirements: Do not use frozen materials or materials mixed or coated with ice or frost. Do not build on frozen substrates. Remove and replace unit masonry damaged by frost or by freezing conditions. Comply with cold-weather construction requirements contained in TMS 602/ACI 530.1/ASCE 6.
 - 1. Cold-Weather Cleaning: Use liquid cleaning methods only when air temperature is 40 deg F (4 deg C) and higher and will remain so until masonry has dried, but not less than seven days after completing cleaning.
- E. Hot-Weather Requirements: Comply with hot-weather construction requirements contained in TMS 602/ACI 530.1/ASCE 6.

PART 2 - PRODUCTS

2.01 MANUFACTURERS

- A. Source Limitations for Masonry Units: Obtain exposed masonry units of a uniform texture and color, or a uniform blend within the ranges accepted for these characteristics, from single source from single manufacturer for each product required.
- B. Source Limitations for Mortar Materials: Obtain mortar ingredients of a uniform quality, including color for exposed masonry, from single manufacturer.

2.02 PERFORMANCE REQUIREMENTS

- A. Provide structural unit masonry that develops indicated net-area compressive strengths at 28 days.
 - 1. Determine net-area compressive strength of masonry from average net-area compressive strengths of masonry units and mortar types (unit-strength method) according to TMS 602/ACI 530.1/ASCE 6.
 - 2. Determine net-area compressive strength of masonry by testing masonry prisms according to ASTM C 1314.

2.03 UNIT MASONRY, GENERAL

- A. Masonry Standard: Comply with TMS 602/ACI 530.1/ASCE 6 except as modified by requirements in the Contract Documents.
- B. Provide units fabricated with integral water repellent admixture.
- C. Defective Units: Referenced masonry unit standards may allow a certain percentage of units to contain chips, cracks, or other defects exceeding limits stated. Do not use units where such defects are exposed in the completed Work.

2.04 CONCRETE MASONRY UNITS

- A. Shapes: Provide shapes indicated and as follows, with exposed surfaces matching exposed faces of adjacent units unless otherwise indicated.
 - 1. Provide special shapes with double finished faces as required for lintels, corners, jambs, sashes, movement joints, headers, bonding, and other special conditions.
 - 2. Provide square-edged units for outside corners unless otherwise indicated.
- B. CMUs: ASTM C 90.
 - 1. Unit Compressive Strength: Provide units with minimum average net-area compressive strength of 3050 psi (21.0 MPa).
 - 2. Density Classification: Normal weight unless otherwise indicated.
 - 3. Size (Width): Manufactured to dimensions 1/8 inch (3 mm) less-than-nominal dimensions.
 - 4. Exposed Faces: Provide color and texture matching the range represented by Architect's sample.
 - 5. Faces to Receive Plaster: Where units are indicated to receive a direct application of plaster, provide textured-face units made with gap-graded aggregates.
- C. Decorative Polished/Ground CMUs: ASTM C 90.
 - 1. **Basis of Design Manufacturer: Trenwyth**
 - a. Polished concrete masonry units: Trendstone Plus, complying with ASTM C744-08
 - 2. Unit Compressive Strength: Provide units with minimum average net-area compressive strength of 3050 psi (21.0 MPa).
 - 3. Density Classification: Normal weight.
 - 4. Size (Width): Manufactured to dimensions specified in "CMUs" Paragraph.
 - 5. Pattern and Texture:
 - a. Standard pattern, ground and polished face finish.
 - 1) Provide ground faced units at interior locations as indicated on Drawings
 - 2) Provide polished units at all exterior locations
 - b. Scored units as indicated on Drawings
 - 1) Provide mid-scored units for all exterior units.
 - 2) Provide non-scored units for interiors where indicated on Drawings
 - c. Provide factory finished edges.
 - 6. Colors:
 - a. Exterior Units: "As selected by Owner from manufacturer's standard range".
 - b. Interior Units: "Alamo"
 - 7. Special Aggregate: Provide units made with aggregate matching aggregate in Architect's sample.

- D. **Pre-faced Glazed CMUs:** Lightweight or medium weight hollow concrete units complying with ASTM C 90, with manufacturer's standard smooth resinous facing complying with ASTM C 744.
1. **Basis of Design Manufacturer: Trenwyth**
 - a. Glazed concrete masonry units: Astra-Glaze-SW
 2. **Unit Compressive Strength:** Provide units with minimum average net-area compressive strength of 3050 psi (21.0 MPa).
 3. **Size:** Manufactured to dimensions specified in "CMUs" Paragraph but with pre-faced surfaces having 1/16-inch- (1.5-mm-) wide returns of facing to create 1 mortar joints with modular coursing. Provide factory finished edges.
 4. **Colors and Patterns:** Scored and patterned units with colors as indicated on Drawings.

2.05 MASONRY LINTELS

- A. **Masonry Lintels:** Prefabricated or built-in-place masonry lintels made from bond beam CMUs matching adjacent CMUs in color, texture, and density classification, with reinforcing bars placed as indicated and filled with coarse grout. Cure precast lintels before handling and installing. Temporarily support built-in-place lintels until grout is fully cured. Provide CMU with finished face at both side and bottom where exposed to view.

2.06 MORTAR AND GROUT MATERIALS

- A. **Portland Cement:** ASTM C 150/C 150M, Type I or II, except Type III may be used for cold-weather construction. Provide natural color and white cement as required to produce mortar color indicated.
1. Alkali content shall not be more than 0.1 percent when tested according to ASTM C 114.
- B. **Hydrated Lime:** ASTM C 207, Type S.
- C. **Portland Cement-Lime Mix:** Packaged blend of portland cement and hydrated lime containing no other ingredients.
- D. **Colored Cement Products:** Do not use coloring admixtures. Color to be derived from actual color of cement.
- E. **Aggregate for Mortar:** ASTM C 144.
1. For mortar that is exposed to view, use washed aggregate consisting of natural sand or crushed stone.
 2. For joints less than 1/4 inch (6 mm) thick, use aggregate graded with 100 percent passing the No. 16 (1.18-mm) sieve.
 3. **White-Mortar Aggregates:** Natural white sand or crushed white stone.
 4. **Grey-Mortar Aggregates:** Natural sand or crushed stone of color necessary to produce grey mortar color.
- F. **Aggregate for Grout:** ASTM C 404.
- G. **Water-Repellent Admixture:** Liquid water-repellent mortar admixture intended for use with CMUs containing integral water repellent from same manufacturer.
- H. **Water:** Drinkable.

2.07 REINFORCEMENT

- A. **Uncoated Steel Reinforcing Bars:** ASTM A 615/A 615M or ASTM A 996/A 996M, Grade 60 (Grade 420).
- B. **Reinforcing Bar Positioners:** Wire units designed to fit into mortar bed joints spanning masonry unit cells and to hold reinforcing bars in center of cells. Units are formed from 0.148-inch (3.77-mm) steel wire, hot-dip galvanized after fabrication. Provide units designed for number of bars indicated.
- C. **Masonry-Joint Reinforcement, General:** Ladder type complying with ASTM A 951/A 951M.
 - 1. **Walls:** Hot-dip galvanized carbon steel.
 - 2. **Wire Size for Side Rods** 0.187-inch (4.76-mm) diameter.
 - 3. **Wire Size for Cross Rods** 0.187-inch (4.76-mm) diameter.
 - 4. **Spacing of Cross Rods:** Not more than 16 inches (407 mm) o.c.
 - 5. Provide in lengths of not less than 10 feet (3 m), with prefabricated corner and tee units.

2.08 TIES AND ANCHORS

- A. **General:** Ties and anchors shall extend at least 1-1/2 inches (38 mm) into masonry but with at least a 5/8-inch (16-mm) cover on outside face. Provide ties sufficient to meet criteria specified on drawings. Secure backplates directly to masonry wall at maximum 16 inch x 16 inch centers.
- B. **Materials:** Provide ties and anchors specified in this article that are made from materials that comply with the following unless otherwise indicated:
 - 1. **Hot-Dip Galvanized, Carbon-Steel Wire:** ASTM A 82/A 82M, with ASTM A 153/A 153M, Class B-2 coating.
 - 2. **Galvanized-Steel Sheet:** ASTM A 653/A 653M, Commercial Steel, G60 (Z180) zinc coating.
 - 3. **Steel Sheet, Galvanized after Fabrication:** ASTM A 1008/A 1008M, Commercial Steel, with ASTM A 153/A 153M, Class B coating.
 - 4. **Steel Plates, Shapes, and Bars:** ASTM A 36/A 36M.
- C. **Adjustable Anchors for Connecting to Structural Steel Framing:** Provide anchors that allow vertical or horizontal adjustment but resist tension and compression forces perpendicular to plane of wall.
 - 1. **Anchor Section for Welding to Steel Frame:** Crimped 1/4-inch- (6.35-mm-) diameter, hot-dip galvanized steel wire.
 - 2. **Tie Section:** Triangular-shaped wire tie made from 0.187-inch- (4.76-mm-) diameter, hot-dip galvanized steel wire.
- D. **Partition Top Anchors:** 0.105-inch- (2.66-mm-) thick metal plate with a 3/8-inch- (9.5-mm-) diameter metal rod 6 inches (152 mm) long welded to plate and with closed-end plastic tube fitted over rod that allows rod to move in and out of tube. Fabricate from steel.

2.09 EMBEDDED FLASHING MATERIALS

- A. **Metal Flashing:** Provide metal flashing complying with SMACNA's "Architectural Sheet Metal Manual" and as follows:
 - 1. **Stainless Steel Fabric:** ASTM A 240/A 240M or ASTM A 666, Type 304, flexible 2 mil sheet of permanently bonded on one side to a layer of polymeric fabric, equal to York Multi-Flash SS.

2. **Stainless Steel Self Adhering Fabric:** ASTM A 240/A 240M or ASTM A 666, Type 304, flexible 2 mil sheet of permanently bonded to minimum 8 mils of butyl adhesive and a siliconized release liner, equal to York 304 flexible self-adhering stainless steel flashing.
3. **Fabricate continuous flashings** in sections 96 inches (2400 mm) long minimum, but not exceeding 12 feet (3.7 m). Provide splice plates at joints of formed, smooth metal flashing.
4. **Fabricate through-wall metal flashing** embedded in masonry from .016 inch thick stainless steel, with ribs at 3-inch (76-mm) intervals along length of flashing to provide an integral mortar bond.
5. **Fabricate through-wall flashing** with snaplock receiver on exterior face where indicated to receive counterflashing.
6. **Fabricate through-wall flashing** with drip edge. Fabricate by extending flashing 1/2 inch (13 mm) out from wall, with outer edge bent down 30 degrees and hemmed.
7. **Fabricate metal drip edges** for ribbed metal flashing from plain metal flashing of same metal as ribbed flashing and extending at least 3 inches (76 mm) into wall with hemmed inner edge to receive ribbed flashing and form a hooked seam. Form hem on upper surface of metal so that completed seam sheds water.

B. Application: Unless otherwise indicated, use the following:

1. Where flashing is indicated to receive counterflashing, use metal fabric flashing.
2. Where flashing is indicated to be turned down at or beyond the wall face, use metal fabric flashing.
3. Where flashing is partly exposed and is indicated to terminate at the wall face, use metal fabric flashing.
4. Where flashing is fully concealed, use metal fabric and metal self-adhering fabric flashings as detailed.
5. Use metal self-adhering fabric flashing over joints in and termination of metal fabric flashings.

C. Adhesives, Primers, and Seam Tapes for Flashings: Flashing manufacturer's standard products or products recommended by flashing manufacturer for bonding flashing sheets to each other and to substrates.

2.010 MISCELLANEOUS MASONRY ACCESSORIES

- A. **Compressible Filler:** Premolded filler strips complying with ASTM D 1056, Grade 2A1; compressible up to 35 percent; of width and thickness indicated; formulated from neoprene.
- B. **Bond-Breaker Strips:** Asphalt-saturated felt complying with ASTM D 226/D 226M, Type I (No. 15 asphalt felt).

2.011 MORTAR AND GROUT MIXES

- A. **General:** Do not use admixtures, including pigments, air-entraining agents, accelerators, retarders, water-repellent agents, antifreeze compounds, or other admixtures unless otherwise indicated.
 1. Do not use calcium chloride in mortar or grout.

- B. **Preblended, Dry Mortar Mix:** Furnish dry mortar ingredients in form of a preblended mix. Measure quantities by weight to ensure accurate proportions, and thoroughly blend ingredients before delivering to Project site.
- C. **Mortar for Interior and Unexposed Unit Masonry:** Comply with ASTM C 270, Property Specification, natural grey color. Provide the Type N mortar for applications stated unless another type is indicated.
- D. **Mortar for Exposed Exterior Masonry:** White colored-aggregate mortar, produced by using white aggregates and white cement as necessary to produce required white mortar color to match Architect's sample.
- E. **Grout for Unit Masonry:** Comply with ASTM C 476.
 - 1. Use grout of type indicated or, if not otherwise indicated, of type (fine or coarse) that will comply with TMS 602/ACI 530.1/ASCE 6 for dimensions of grout spaces and pour height.
 - 2. Proportion grout in accordance with ASTM C 476, paragraph 4.2.2 for specified 28-day compressive strength indicated, but not less than 2000 psi (14 MPa)].
 - 3. Provide grout with a slump of 10 to 11 inches (250 to 280 mm)] as measured according to ASTM C 143/C 143M.

PART 3 - EXECUTION

3.01 EXAMINATION

- A. **Examine conditions, with Installer present, for compliance with requirements for installation tolerances and other conditions affecting performance of the Work.**
 - 1. For the record, prepare written report, endorsed by Installer, listing conditions detrimental to performance of the Work.
 - 2. Verify that foundations are within tolerances specified.
 - 3. Verify that reinforcing dowels are properly placed.
 - 4. Verify that substrates are free of substances that would impair mortar bond.
- B. **Before installation, examine rough-in and built-in construction for piping systems to verify actual locations of piping.**
- C. **Proceed with installation only after unsatisfactory conditions have been corrected.**

3.02 INSTALLATION, GENERAL

- A. **Build chases and recesses, and install conduits and anchorages to accommodate items specified in this and other Sections.**
- B. **Leave openings for equipment to be installed before completing masonry. After installing equipment, complete masonry to match construction immediately adjacent to opening.**
- C. **Use full-size units without cutting if possible. If cutting is required to provide a continuous pattern or to fit adjoining construction, cut units with motor-driven saws; provide clean, sharp, unchipped edges. Allow units to dry before laying unless wetting of units is specified. Install cut units with cut surfaces and, where possible, cut edges concealed. Do not horizontally cut glazed masonry units unless approved in writing by Architect.**

3.03 TOLERANCES

A. Dimensions and Locations of Elements:

1. For dimensions in cross section or elevation, do not vary by more than plus 1/4 inch (6 mm) or minus 1/8 inch (3 mm).
2. For location of elements in plan, do not vary from that indicated by more than plus or minus 1/4 inch (6 mm).
3. For location of elements in elevation, do not vary from that indicated by more than plus or minus 1/4 inch (6 mm) total.

B. Lines and Levels:

1. For bed joints and top surfaces of bearing walls, do not vary from level by more than 1/4 inch in 10 feet (6 mm in 3 m), or 1/2-inch (12-mm) maximum.
2. For conspicuous horizontal lines, such as lintels, sills, parapets, and reveals, do not vary from level by more than 1/8 inch in 10 feet (3 mm in 3 m), 1/4 inch in 20 feet (6 mm in 6 m), or 1/2-inch (12-mm) maximum.
3. For vertical lines and surfaces do not vary from plumb by more than 1/4 inch in 10 feet (6 mm in 3 m), 3/8 inch in 20 feet (9 mm in 6 m), or 1/2-inch (12-mm) maximum.
4. For conspicuous vertical lines, such as external corners, door jambs, reveals, and expansion and control joints, do not vary from plumb by more than 1/8 inch in 10 feet (3 mm in 3 m), 1/4 inch in 20 feet (6 mm in 6 m), or 1/2-inch (12-mm) maximum.
5. For lines and surfaces, do not vary from straight by more than 1/4 inch in 10 feet (6 mm in 3 m), 3/8 inch in 20 feet (9 mm in 6 m), or 1/2-inch (12-mm) maximum.
6. For vertical alignment of exposed head joints, do not vary from plumb by more than 1/4 inch in 10 feet (6 mm in 3 m), or 1/2-inch (12-mm) maximum.
7. For faces of adjacent exposed masonry units, do not vary from flush alignment by more than 1/16 inch (1.5 mm).

C. Joints:

1. For bed joints, do not vary from thickness indicated by more than plus or minus 1/8 inch (3 mm), with a maximum thickness limited to 1/2 inch (12 mm).
2. For exposed bed joints, do not vary from bed-joint thickness of adjacent courses by more than 1/8 inch (3 mm).
3. For head and collar joints, do not vary from thickness indicated by more than plus 3/8 inch (9 mm) or minus 1/4 inch (6 mm).
4. For exposed head joints, do not vary from thickness indicated by more than plus or minus 1/8 inch (3 mm).

3.04 LAYING MASONRY WALLS

- A. Lay out walls in advance for accurate spacing of surface bond patterns with uniform joint thicknesses and for accurate location of openings, movement-type joints, returns, and offsets. Avoid using less-than-half-size units, particularly at corners, jambs, and, where possible, at other locations.
- B. **Bond Pattern for Exposed Masonry:** Unless otherwise indicated, lay exposed masonry in stack bond pattern indicated on Drawings; do not use units with less-than-nominal 4-inch (100-mm) horizontal face dimensions at corners or jambs.
- C. Lay concealed masonry with all units in a wythe in running bond or bonded by lapping not less than 4 inches (100 mm). Bond and interlock each course of each wythe at corners. Do not use units with less-than-nominal 4-inch (100-mm) horizontal face dimensions at corners or jambs.

- D. **Stopping and Resuming Work:** Stop work by stepping back units in each course from those in course below; do not tooth. When resuming work, clean masonry surfaces that are to receive mortar, remove loose masonry units and mortar, and wet brick if required before laying fresh masonry.
- E. **Built-in Work:** As construction progresses, build in items specified in this and other Sections. Fill in solidly with masonry around built-in items.
- F. **Fill space between steel frames and masonry solidly with mortar unless otherwise indicated.**
- G. **Where built-in items are to be embedded in cores of hollow masonry units, place a layer of metal lath, wire mesh, or plastic mesh in the joint below, and rod mortar or grout into core.**
- H. **Fill cores in hollow CMUs with grout 24 inches (600 mm) under bearing plates, beams, lintels, posts, and similar items unless otherwise indicated.**
- I. **Build nonload-bearing interior partitions full height of story to underside of roof structure above unless otherwise indicated.**
 - 1. **Install compressible filler in joint between top of partition and underside of structure above. Fill and seal with expanding foam sealant.**

3.05 MORTAR BEDDING AND JOINTING

- A. **Lay hollow CMUs as follows:**
 - 1. **Bed face shells in mortar and make head joints of depth equal to bed joints.**
 - 2. **Bed webs in mortar in all courses of piers, columns, and pilasters.**
 - 3. **Bed webs in mortar in grouted masonry, including starting course on footings.**
 - 4. **Fully bed entire units, including areas under cells, at starting course on footings where cells are not grouted.**
- B. **Lay solid CMUs with completely filled bed and head joints; butter ends with sufficient mortar to fill head joints and shove into place. Do not deeply furrow bed joints or slush head joints.**
- C. **Tool exposed joints slightly concave when thumbprint hard, using a jointer larger than joint thickness unless otherwise indicated.**
- D. **Cut joints flush where indicated to receive flashing or liquid air barrier unless otherwise indicated.**

3.06 MASONRY-JOINT REINFORCEMENT

- A. **General: Install entire length of longitudinal side rods in mortar with a minimum cover of 5/8 inch (16 mm) on exterior side of walls, 1/2 inch (13 mm) elsewhere. Lap reinforcement a minimum of 6 inches (150 mm).**
 - 1. **Space reinforcement not more than 16 inches (406 mm) o.c.**
 - 2. **Provide reinforcement not more than 8 inches (203 mm) above and below wall openings and extending 12 inches (305 mm) beyond openings.**
 - 3. **Coordinate spacing and location of ties with rigid insulation installation.**
- B. **Interrupt joint reinforcement at control joints unless otherwise indicated.**

- C. Provide continuity at wall intersections by using prefabricated T-shaped units.
- D. Provide continuity at corners by using prefabricated L-shaped units.

3.07 ANCHORING MASONRY TO STRUCTURAL STEEL AND CONCRETE

- A. Anchor masonry to structural steel and concrete, where masonry abuts or faces structural steel or concrete, to comply with the following:
 1. Provide an open space not less than 1/2 inch (13 mm) wide between masonry and structural steel or concrete unless otherwise indicated. Keep open space free of mortar and other rigid materials.
 2. Anchor masonry with anchors embedded in masonry joints and attached to structure.
 3. Space anchors as indicated, but not more than 24 inches (610 mm) o.c. vertically and 36 inches (915 mm) o.c. horizontally.

3.08 CONTROL AND EXPANSION JOINTS

- A. General: Install control- and expansion-joint materials where indicated on Drawings, in unit masonry as masonry progresses. Do not allow materials to span control and expansion joints without provision to allow for in-plane wall or partition movement.
- B. Form control joints in concrete masonry by installing temporary foam-plastic filler in head joints, and remove filler when unit masonry is complete for application of sealant.

3.09 LINTELS

- A. Provide masonry lintels where shown and where openings of more than 24 inches (610 mm) are shown without structural steel or other supporting lintels. Install lintels with special blocks finished on exposed sides to match adjacent wall finishes.
- B. Provide minimum bearing of 8 inches (200 mm) at each jamb unless otherwise indicated.

3.010 FLASHING

- A. General: Install embedded flashing at ledges and other obstructions to downward flow of water in wall where indicated.
- B. Install flashing as follows unless otherwise indicated:
 1. Prepare masonry surfaces so they are smooth and free from projections that could puncture flashing. Where flashing is within mortar joint, place through-wall flashing on sloping bed of mortar and cover with mortar. Before covering with mortar, seal penetrations in flashing with sealant.
 2. At lintels, extend flashing a minimum of 6 inches (150 mm) into masonry at each end. At heads and sills, extend flashing 6 inches (150 mm) at ends and turn up not less than 2 inches (50 mm) to form end dams.
 3. Interlock end joints of metal flashing by overlapping ribs not less than 1-1/2 inches (38 mm) or as recommended by flashing manufacturer, and seal lap with compatible sealant and covering with 3 inch strip of self-adhering metal flashing.
 4. Cut flexible flashing off flush with face of wall after masonry wall construction is completed.

- C. Install CMU cell pans with upturned edges located below face shells and webs of CMUs above and with weep spouts aligned with face of wall.
- D. Install reglets and nailers for flashing and other related construction where they are shown to be built into masonry.

3.011 INSULATION INSTALLATION

- A. Verify installation of air barrier and flashings have been approved prior to installation of insulation.
- B. Install rigid insulation in cavity wall continuous without gaps and void secured to substrate with adhesives. Where items protrude cut and fit tightly around items,
- C. Seal open joints and annular spaces around protruding objects with a compatible expanding foam sealant.
- D. Ensure required air space is maintained between insulation and veneers.

3.012 REINFORCED UNIT MASONRY INSTALLATION

- A. Temporary Formwork and Shores: Construct formwork and shores as needed to support reinforced masonry elements during construction.
 1. Construct formwork to provide shape, line, and dimensions of completed masonry as indicated. Make forms sufficiently tight to prevent leakage of mortar and grout. Brace, tie, and support forms to maintain position and shape during construction and curing of reinforced masonry.
 2. Do not remove forms and shores until reinforced masonry members have hardened sufficiently to carry their own weight and other loads that may be placed on them during construction.
- B. Placing Reinforcement: Comply with requirements in TMS 602/ACI 530.1/ASCE 6.
- C. Grouting: Do not place grout until entire height of masonry to be grouted has attained enough strength to resist grout pressure.
 1. Comply with requirements in TMS 602/ACI 530.1/ASCE 6 for cleanouts and for grout placement, including minimum grout space and maximum pour height.
 2. Limit height of vertical grout pours to not more than 60 inches (1520 mm).

3.013 FIELD QUALITY CONTROL

- A. Testing and Inspecting: Owner will engage special inspectors to perform tests and inspections and prepare reports. Allow inspectors access to scaffolding and work areas as needed to perform tests and inspections. Retesting of materials that fail to comply with specified requirements shall be done at Contractor's expense.
- B. Inspections: Special inspections according to Level B in TMS 402/ACI 530/ASCE 5.
 1. Begin masonry construction only after inspectors have verified proportions of site-prepared mortar.

2. Place grout only after inspectors have verified compliance of grout spaces and of grades, sizes, and locations of reinforcement.
 3. Place grout only after inspectors have verified proportions of site-prepared grout.
- C. Testing Prior to Construction: One set of tests.
- D. Testing Frequency: One set of tests for each 500 sq. ft. (46 sq. m) of wall area or portion thereof.
- E. Concrete Masonry Unit Test: For each type of unit provided, according to ASTM C 140 for compressive strength.
- F. Mortar Aggregate Ratio Test (Proportion Specification): For each mix provided, according to ASTM C 780.
- G. Mortar Test (Property Specification): For each mix provided, according to ASTM C 780. Test mortar for mortar air content and compressive strength.
- H. Grout Test (Compressive Strength): For each mix provided, according to ASTM C 1019.
- I. Prism Test: For each type of construction provided, according to ASTM C 1314 at 7 days and at 28 days.

3.014 REPAIRING, POINTING, AND CLEANING

- A. Remove and replace masonry units that are loose, chipped, broken, stained, or otherwise damaged or that do not match adjoining units. Install new units to match adjoining units; install in fresh mortar, pointed to eliminate evidence of replacement.
- B. Pointing: During the tooling of joints, enlarge voids and holes, except weep holes, and completely fill with mortar. Point up joints, including scored joints, corners, openings, and adjacent construction, to provide a neat, uniform appearance. Prepare control joints for sealant and backer rod application.
- C. In-Progress Cleaning: Clean unit masonry as work progresses by dry brushing to remove mortar fins and smears before tooling joints.
- D. Final Cleaning: After mortar is thoroughly set and cured, clean exposed masonry as follows:
1. Remove large mortar particles by hand with wooden paddles and nonmetallic scrape hoes or chisels.
 2. Test cleaning methods on sample wall panel; leave one-half of panel uncleaned for comparison purposes. Obtain Architect's approval of sample cleaning before proceeding with cleaning of masonry.
 3. Clean concrete masonry by applicable cleaning methods as directed in writing by unit manufacturer.

3.015 MASONRY WASTE DISPOSAL

- A. Salvageable Materials: Unless otherwise indicated, excess masonry materials are Contractor's property. At completion of unit masonry work, remove from Project site.

- B. **Waste Disposal as Fill Material:** Dispose of clean masonry waste, including excess or soil-contaminated sand, waste mortar, and broken masonry units, by crushing and mixing with fill material as fill is placed.
 - 1. Crush masonry waste to less than 4 inches (100 mm) in each dimension.
 - 2. Mix masonry waste with at least two parts of specified fill material for each part of masonry waste.
 - 3. Do not dispose of masonry waste as fill within 18 inches (450 mm) of finished grade.
- C. **Masonry Waste Recycling:** Return broken CMUs not used as fill to manufacturer for recycling.
- D. **Excess Masonry Waste:** Remove excess clean masonry waste that cannot be used as fill, as described above or recycled, and other masonry waste, and legally dispose of off Owner's property.

3.016 PAYMENT

- A. Lump sum price for Architectural Construction Maintenance Building covers all items of work in this Special Provision including furnishing labor, materials, tools, equipment, and incidentals required to complete the work.

END OF SECTION

State Road and Tollway Authority (SRTA), State of Georgia

SPECIAL PROVISION

Section 763 – Bus Pavilion and/or Section 999 – Architectural Construction Maintenance Building

Section 051200 – Structural Steel Framing

PART 1 - GENERAL

1.01 SUMMARY

A. Section Includes:

1. Structural steel.
2. Prefabricated building columns.
3. Field-installed shear connectors.
4. Non-Shrink Grout.

B. Related Requirements:

1. Section 051213 "Architecturally Exposed Structural Steel Framing" for additional requirements for architecturally exposed structural steel.
2. Section 053100 "Steel Decking" for field installation of shear connectors through deck.
3. Section 055000 "Metal Fabrications" for steel lintels and shelf angles not attached to structural-steel frame, miscellaneous steel fabrications and other steel items not defined as structural steel.
4. Section 099113 "Exterior Painting" and Section 099123 "Interior Painting" for surface-preparation and priming requirements.

1.02 DEFINITIONS

- A. Structural Steel: Elements of the structural frame indicated on Drawings and as described in AISC 303, "Code of Standard Practice for Steel Buildings and Bridges."
- B. Seismic-Load-Resisting System: Elements of structural-steel frame designated as "SLRS" or along grid lines designated as "SLRS" on Drawings, including columns, beams, and braces and their connections.
- C. Heavy Sections: Rolled and built-up sections as follows:
 1. Shapes included in ASTM A 6/A 6M with flanges thicker than 1-1/2 inches (38 mm).
 2. Welded built-up members with plates thicker than 2 inches (50 mm).
 3. Column base plates thicker than 2 inches (50 mm).

- D. **Protected Zone:** Structural members or portions of structural members indicated as "Protected Zone" on Drawings. Connections of structural and nonstructural elements to protected zones are limited.
- E. **Demand Critical Welds:** Those welds, the failure of which would result in significant degradation of the strength and stiffness of the Seismic-Load-Resisting System and which are indicated as "Demand Critical" or "Seismic Critical" on Drawings.

1.03 COORDINATION

- A. Coordinate selection of shop primers with topcoats to be applied over them. Comply with paint and coating manufacturers' written recommendations to ensure that shop primers and topcoats are compatible with one another.
- B. Coordinate installation of anchorage items to be embedded in or attached to other construction without delaying the Work. Provide setting diagrams, sheet metal templates, instructions, and directions for installation.

1.04 PREINSTALLATION MEETINGS

- A. **Preinstallation Conference:** Conduct conference at Project site.

1.05 ACTION SUBMITTALS

- A. **Product Data:** For each type of product.
- B. **Sustainable Design Submittals:** Refer to Section 018113 - Sustainable Design Requirements for requirements to attain LEED Certification required by the Section.
- C. **Shop Drawings:** Show fabrication of structural-steel components.
 1. Include details of cuts, connections, splices, camber, holes, and other pertinent data.
 2. Include embedment Drawings.
 3. Indicate welds by standard AWS symbols, distinguishing between shop and field welds, and show size, length, and type of each weld. Show backing bars that are to be removed and supplemental fillet welds where backing bars are to remain.
 4. Indicate type, size, and length of bolts, distinguishing between shop and field bolts. Identify pretensioned and slip-critical, high-strength bolted connections.
 5. Identify members and connections of the Seismic-Load-Resisting System.
 6. Indicate locations and dimensions of protected zones.
 7. Identify demand critical welds.
- D. **Welding Procedure Specifications (WPSs) and Procedure Qualification Records (PQRs):** Provide according to AWS D1.1/D1.1M, "Structural Welding Code - Steel," for each welded joint whether prequalified or qualified by testing, including the following:
 1. Power source (constant current or constant voltage).
 2. Electrode manufacturer and trade name, for demand critical welds.
- E. **Delegated-Design Submittal:** For structural-steel connections indicated to comply with design loads, include analysis data signed and sealed by the qualified professional engineer responsible for their preparation.

1.06 INFORMATIONAL SUBMITTALS

- A. Qualification Data: For professional engineer.
- B. Welding certificates.
- C. Paint Compatibility Certificates: From manufacturers of topcoats applied over shop primers, certifying that shop primers are compatible with topcoats.
- D. Mill test reports for structural steel, including chemical and physical properties.
- E. Product Test Reports: For the following:
 - 1. Bolts, nuts, and washers including mechanical properties and chemical analysis.
 - 2. Direct-tension indicators.
 - 3. Tension-control, high-strength, bolt-nut-washer assemblies.
 - 4. Shear stud connectors.
 - 5. Shop primers.
 - 6. Nonshrink grout.
- F. Survey of existing conditions.
- G. Source quality-control reports.
- H. Field quality-control and special inspection reports.

1.07 QUALITY ASSURANCE

- A. Fabricator Qualifications: A qualified fabricator that participates in the AISC Quality Certification Program and is designated an AISC-Certified Plant, Category STD, or is accredited by the IAS Fabricator Inspection Program for Structural Steel (AC 172).
- B. Installer Qualifications: A qualified installer who participates in the AISC Quality Certification Program and is designated an AISC-Certified Erector, Category ACSE
- C. Shop-Painting Applicators: Qualified according to AISC's Sophisticated Paint Endorsement P1 or to SSPC-QP 3, "Standard Procedure for Evaluating Qualifications of Shop Painting Applicators."
- D. Welding Qualifications: Qualify procedures and personnel according to AWS D1.1/D1.1M, "Structural Welding Code - Steel."
 - 1. Welders and welding operators performing work on bottom-flange, demand-critical welds shall pass the supplemental welder qualification testing, as required by AWS D1.8/D1.8M. FCAW-S and FCAW-G shall be considered separate processes for welding personnel qualification.
- E. Comply with applicable provisions of the following specifications and documents:
 - 1. AISC 303.
 - 2. AISC 341 and AISC 341s1.
 - 3. AISC 360.
 - 4. RCSC's "Specification for Structural Joints Using ASTM A 325 or A 490 Bolts."

1.08 DELIVERY, STORAGE, AND HANDLING

- A. Store materials to permit easy access for inspection and identification. Keep steel members off ground and spaced by using pallets, dunnage, or other supports and spacers. Protect steel members and packaged materials from corrosion and deterioration.
 - 1. Do not store materials on structure in a manner that might cause distortion, damage, or overload to members or supporting structures. Repair or replace damaged materials or structures as directed.
- B. Store fasteners in a protected place in sealed containers with manufacturer's labels intact.
 - 1. Fasteners may be repackaged provided Owner's testing and inspecting agency observes repackaging and seals containers.
 - 2. Clean and relubricate bolts and nuts that become dry or rusty before use.
 - 3. Comply with manufacturers' written recommendations for cleaning and lubricating ASTM F 1852 fasteners and for retesting fasteners after lubrication.

PART 2 - PRODUCTS**2.01 PERFORMANCE REQUIREMENTS**

- A. Connections: Provide details of simple shear connections required by the Contract Documents to be selected or completed by structural-steel fabricator to withstand loads indicated and comply with other information and restrictions indicated.
 - 1. Select and complete connections using schematic details indicated and AISC 360.
 - 2. Use Allowable Stress Design; data are given at service-load level.
- B. Construction: Shear wall system.

2.02 STRUCTURAL-STEEL MATERIALS

- A. W-Shapes: ASTM A 992/A 992M.
- B. Channels, Angles, M , S-Shapes: ASTM A 36/A 36M.
- C. Plate and Bar: ASTM A 36/A 36M.
- D. Corrosion-Resisting Structural-Steel Shapes, Plates, and Bars: ASTM A 588/A 588M, Grade 50 (345).
- E. Cold-Formed Hollow Structural Sections: ASTM A 500/A 500M, Grade B, structural tubing.
- F. Corrosion-Resisting, Cold-Formed Hollow Structural Sections: ASTM A 847/A 847M, structural tubing.
- G. Steel Pipe: ASTM A 53/A 53M, Type E or Type S, Grade B.
 - 1. Weight Class: Standard.
 - 2. Finish: Galvanized.

- H. Steel Castings: ASTM A 216/A 216M, Grade WCB with supplementary requirement S11.
- I. Steel Forgings: ASTM A 668/A 668M.
- J. Welding Electrodes: Comply with AWS requirements.

2.03 BOLTS, CONNECTORS, AND ANCHORS

- A. High-Strength Bolts, Nuts, and Washers: ASTM A 325 (ASTM A 325M), Type 1, heavy-hex steel structural bolts; ASTM A 563, Grade C, (ASTM A 563M, Class 8S) heavy-hex carbon-steel nuts; and ASTM F 436 (ASTM F 436M), Type 1, hardened carbon-steel washers; all with plain finish.
 - 1. Direct-Tension Indicators: ASTM F 959, Type 325 (ASTM F 959M, Type 8.8), compressible-washer type with plain finish.
- B. Shear Connectors: ASTM A 108, Grades 1015 through 1020, headed-stud type, cold-finished carbon steel; AWS D1.1/D1.1M, Type B.
- C. Headed Anchor Rods: ASTM F 1554, Grade 36 ASTM F 1554, Grade 55, weldable, straight.
 - 1. Nuts: ASTM A 563 (ASTM A 563M) heavy-hex carbon steel.
 - 2. Plate Washers: ASTM A 36/A 36M carbon steel.
 - 3. Washers: ASTM F 436 (ASTM F 436M), Type 1, hardened carbon steel.
 - 4. Finish: Plain.
- D. Threaded Rods: ASTM A 36/A 36M .
 - 1. Nuts: ASTM A 563 (ASTM A 563M) heavy-hex carbon steel.
 - 2. Washers: ASTM F 436 (ASTM F 436M), Type 1, hardened carbon steel.
 - 3. Finish: Plain.
- E. Eye Bolts and Nuts: Made from cold-finished carbon steel bars, ASTM A 108, Grade 1030.
- F. Sleeve Nuts: Made from cold-finished carbon steel bars, ASTM A 108, Grade 1018.

2.04 GROUT

- A. Metallic, Shrinkage-Resistant Grout: ASTM C 1107/C 1107M, factory-packaged, metallic aggregate grout, mixed with water to consistency suitable for application and a 30-minute working time.
- B. Nonmetallic, Shrinkage-Resistant Grout: ASTM C 1107/C 1107M, factory-packaged, nonmetallic aggregate grout, noncorrosive and nonstaining, mixed with water to consistency suitable for application and a 30-minute working time.

2.05 FABRICATION

- A. Structural Steel: Fabricate and assemble in shop to greatest extent possible. Fabricate according to AISC 303, "Code of Standard Practice for Steel Buildings and Bridges," and to AISC 360.

1. Camber structural-steel members where indicated.
 2. Fabricate beams with rolling camber up.
 3. Identify high-strength structural steel according to ASTM A 6/A 6M and maintain markings until structural steel has been erected.
 4. Mark and match-mark materials for field assembly.
 5. Complete structural-steel assemblies, including welding of units, before starting shop-priming operations.
- B. Thermal Cutting: Perform thermal cutting by machine to greatest extent possible.
1. Plane thermally cut edges to be welded to comply with requirements in AWS D1.1/D1.1M.
- C. Bolt Holes: Cut, drill, mechanically thermal cut, or punch standard bolt holes perpendicular to metal surfaces.
- D. Finishing: Accurately finish ends of columns and other members transmitting bearing loads.
- E. Shear Connectors: Prepare steel surfaces as recommended by manufacturer of shear connectors. Use automatic end welding of headed-stud shear connectors according to AWS D1.1/D1.1M and manufacturer's written instructions.
- F. Steel Wall-Opening Framing: Select true and straight members for fabricating steel wall-opening framing to be attached to structural-steel frame. Straighten as required to provide uniform, square, and true members in completed wall framing. Build up welded framing, weld exposed joints continuously, and grind smooth.
- G. Welded Door Frames: Build up welded door frames attached to structural-steel frame. Weld exposed joints continuously and grind smooth. Plug-weld fixed steel bar stops to frames. Secure removable stops to frames with countersunk machine screws, uniformly spaced not more than 10 inches (250 mm) o.c. unless otherwise indicated.
- H. Holes: Provide holes required for securing other work to structural steel and for other work to pass through steel members.
1. Cut, drill, or punch holes perpendicular to steel surfaces.
 2. Baseplate Holes: Cut, drill, mechanically thermal cut, or punch holes perpendicular to steel surfaces.
 3. Weld threaded nuts to framing and other specialty items indicated to receive other work.

2.06 SHOP CONNECTIONS

- A. High-Strength Bolts: Shop install high-strength bolts according to RCSC's "Specification for Structural Joints Using ASTM A 325 or A 490 Bolts" for type of bolt and type of joint specified.
1. Joint Type: Snug tightened.
- B. Weld Connections: Comply with AWS D1.1/D1.1M and AWS D1.8/D1.8M for tolerances, appearances, welding procedure specifications, weld quality, and methods used in correcting welding work.
1. Assemble and weld built-up sections by methods that maintain true alignment of axes without exceeding tolerances in AISC 303 for mill material.

2.07 PREFABRICATED BUILDING COLUMNS

- A. Prefabricated building columns consisting of load-bearing structural-steel members protected by concrete fireproofing encased in an outer non-load-bearing steel shell.
- B. Fire-Resistance Ratings: Provide prefabricated building column listed and labeled by a testing and inspecting agency acceptable to authorities having jurisdiction for ratings indicated, based on testing according to ASTM E 119.
 - 1. Fire-Resistance Rating: As indicated.

2.08 SHOP PRIMING

- A. Shop prime steel surfaces except the following:
 - 1. Surfaces embedded in concrete or mortar. Extend priming of partially embedded members to a depth of 2 inches (50 mm).
 - 2. Surfaces to be field welded.
 - 3. Surfaces of high-strength bolted, slip-critical connections.
 - 4. Surfaces to receive sprayed fire-resistive materials (applied fireproofing).
 - 5. Galvanized surfaces.
 - 6. Surfaces enclosed in interior construction.
- B. Surface Preparation: Clean surfaces to be painted. Remove loose rust and mill scale and spatter, slag, or flux deposits. Prepare surfaces according to the following specifications and standards:
 - 1. SSPC-SP 3, "Power Tool Cleaning."
- C. Priming and Painting: Refer to Section "Exterior Painting" and Section 099123 "Interior Painting" for requirements.

2.09 SOURCE QUALITY CONTROL

- A. Testing Agency: Owner will engage a qualified testing agency to perform shop tests and inspections.
 - 1. Provide testing agency with access to places where structural-steel work is being fabricated or produced to perform tests and inspections.
- B. Bolted Connections: Inspect and test shop-bolted connections according to RCSC's "Specification for Structural Joints Using ASTM A 325 or A 490 Bolts."
- C. Welded Connections: Visually inspect shop-welded connections according to AWS D1.1/D1.1M and the following inspection procedures, at testing agency's option:
 - 1. Liquid Penetrant Inspection: ASTM E 165.
 - 2. Magnetic Particle Inspection: ASTM E 709; performed on root pass and on finished weld. Cracks or zones of incomplete fusion or penetration are not accepted.
 - 3. Ultrasonic Inspection: ASTM E 164.
 - 4. Radiographic Inspection: ASTM E 94.
- D. In addition to visual inspection, test and inspect shop-welded shear connectors according to requirements in AWS D1.1/D1.1M for stud welding and as follows:

1. Perform bend tests if visual inspections reveal either a less-than-continuous 360-degree flash or welding repairs to any shear connector.
2. Conduct tests according to requirements in AWS D1.1/D1.1M on additional shear connectors if weld fracture occurs on shear connectors already tested.

E. Prepare test and inspection reports.

PART 3 - EXECUTION

3.01 EXAMINATION

- A. Verify, with certified steel erector present, elevations of concrete- and masonry-bearing surfaces and locations of anchor rods, bearing plates, and other embedments for compliance with requirements.
 1. Prepare a certified survey of existing conditions. Include bearing surfaces, anchor rods, bearing plates, and other embedments showing dimensions, locations, angles, and elevations.
- B. Proceed with installation only after unsatisfactory conditions have been corrected.

3.02 PREPARATION

- A. Provide temporary shores, guys, braces, and other supports during erection to keep structural steel secure, plumb, and in alignment against temporary construction loads and loads equal in intensity to design loads. Remove temporary supports when permanent structural steel, connections, and bracing are in place unless otherwise indicated.
 1. Do not remove temporary shoring supporting composite deck construction until cast-in-place concrete has attained its design compressive strength.

3.03 ERECTION

- A. Set structural steel accurately in locations and to elevations indicated and according to AISC 303 and AISC 360.
- B. Baseplates Bearing Plates and Leveling Plates: Clean concrete- and masonry-bearing surfaces of bond-reducing materials, and roughen surfaces prior to setting plates. Clean bottom surface of plates.
 1. Set plates for structural members on wedges, shims, or setting nuts as required.
 2. Weld plate washers to top of baseplate.
 3. Snug-tighten anchor rods after supported members have been positioned and plumbed. Do not remove wedges or shims but, if protruding, cut off flush with edge of plate before packing with grout.
 4. Promptly pack grout solidly between bearing surfaces and plates so no voids remain. Neatly finish exposed surfaces; protect grout and allow to cure. Comply with manufacturer's written installation instructions for shrinkage-resistant grouts.
- C. Maintain erection tolerances of structural steel within AISC 303, "Code of Standard Practice for Steel Buildings and Bridges."

- D. Align and adjust various members that form part of complete frame or structure before permanently fastening. Before assembly, clean bearing surfaces and other surfaces that are in permanent contact with members. Perform necessary adjustments to compensate for discrepancies in elevations and alignment.
 - 1. Level and plumb individual members of structure.
 - 2. Make allowances for difference between temperature at time of erection and mean temperature when structure is completed and in service.
- E. Splice members only where indicated.
- F. Do not use thermal cutting during erection unless approved by Architect. Finish thermally cut sections within smoothness limits in AWS D1.1/D1.1M.
- G. Do not enlarge unfair holes in members by burning or using drift pins. Ream holes that must be enlarged to admit bolts.
- H. Shear Connectors: Prepare steel surfaces as recommended by manufacturer of shear connectors. Use automatic end welding of headed-stud shear connectors according to AWS D1.1/D1.1M and manufacturer's written instructions.

3.04 FIELD CONNECTIONS

- A. High-Strength Bolts: Install high-strength bolts according to RCSC's "Specification for Structural Joints Using ASTM A 325 or A 490 Bolts" for type of bolt and type of joint specified.
 - 1. Joint Type: Snug tightened.
- B. Weld Connections: Comply with AWS D1.1/D1.1M and AWS D1.8/D1.8M for tolerances, appearances, welding procedure specifications, weld quality, and methods used in correcting welding work.
 - 1. Comply with AISC 303 and AISC 360 for bearing, alignment, adequacy of temporary connections, and removal of paint on surfaces adjacent to field welds.
 - 2. Remove backing bars or runoff tabs where indicated, back gouge, and grind steel smooth.
 - 3. Assemble and weld built-up sections by methods that maintain true alignment of axes without exceeding tolerances in AISC 303, "Code of Standard Practice for Steel Buildings and Bridges," for mill material.

3.05 FIELD QUALITY CONTROL

- A. Special Inspections: Owner will engage a qualified special inspector to perform the following special inspections:
 - 1. Verify structural-steel materials and inspect steel frame joint details.
 - 2. Verify weld materials and inspect welds.
 - 3. Verify connection materials and inspect high-strength bolted connections.
- B. Testing Agency: Owner will engage a qualified testing agency to perform tests and inspections.
- C. Bolted Connections: Inspect and test bolted connections according to RCSC's "Specification for Structural Joints Using ASTM A 325 or A 490 Bolts."

- D. **Welded Connections:** Visually inspect field welds according to AWS D1.1/D1.1M.
 - 1. In addition to visual inspection, test and inspect field welds according to AWS D1.1/D1.1M and the following inspection procedures, at testing agency's option:
 - a. **Liquid Penetrant Inspection:** ASTM E 165.
 - b. **Magnetic Particle Inspection:** ASTM E 709; performed on root pass and on finished weld. Cracks or zones of incomplete fusion or penetration are not accepted.
 - c. **Ultrasonic Inspection:** ASTM E 164.
 - d. **Radiographic Inspection:** ASTM E 94.
- E. In addition to visual inspection, test and inspect field-welded shear connectors according to requirements in AWS D1.1/D1.1M for stud welding and as follows:
 - 1. **Perform** bend tests if visual inspections reveal either a less-than-continuous 360-degree flash or welding repairs to any shear connector.
 - 2. **Conduct** tests according to requirements in AWS D1.1/D1.1M on additional shear connectors if weld fracture occurs on shear connectors already tested.

3.06 REPAIRS AND PROTECTION

- A. **Touchup Painting:** Cleaning and touchup painting are specified in Section 099113 "Exterior Painting" and Section 099123 "Interior Painting."

3.07 PAYMENT

- A. **Lump sum price for Bus Pavilion and Architectural Construction Maintenance Building** covers all items of work in this Special Provision including furnishing labor, materials, tools, equipment, and incidentals required to complete the work.

END OF SECTION

State Road and Tollway Authority (SRTA), State of Georgia

SPECIAL PROVISION

Section 763 – Bus Pavilion and/or Section 999 – Architectural Construction Maintenance Building

Section 053100 – Steel Decking

PART 1 - GENERAL

1.01 SUMMARY

A. Section Includes:

1. Roof deck.
2. Noncomposite form deck.

B. Related Requirements:

1. Section 033000 "Cast-in-Place Concrete" for normal-weight and lightweight structural concrete fill over steel deck.
2. Section 051200 "Structural Steel Framing" for shop- and field-welded shear connectors.
3. Section 055000 "Metal Fabrications" for framing deck openings with miscellaneous steel shapes.

1.02 ACTION SUBMITTALS

A. Product Data: For each type of deck, accessory, and product indicated.

B. Shop Drawings:

1. Include layout and types of deck panels, anchorage details, reinforcing channels, pans, cut deck openings, special jointing, accessories, and attachments to other construction.

1.03 INFORMATIONAL SUBMITTALS

A. Welding certificates.

B. Product Certificates: For each type of steel deck.

C. Product Test Reports: Based on evaluation of comprehensive tests performed by a qualified testing agency, indicating that each of the following complies with requirements:

1. Power-actuated mechanical fasteners.

- D. Evaluation Reports: For steel deck.
- E. Field quality-control reports.

1.04 QUALITY ASSURANCE

- A. Testing Agency Qualifications: Qualified according to ASTM E 329 for testing indicated.
- B. Welding Qualifications: Qualify procedures and personnel according to AWS D1.3, "Structural Welding Code - Sheet Steel."
- C. Electrical Raceway Units: Provide UL-labeled cellular floor-deck units complying with UL 209 and listed in UL's "Electrical Construction Equipment Directory" for use with standard header ducts and outlets for electrical distribution systems.
- D. FM Global Listing: Provide steel roof deck evaluated by FM Global and listed in its "Approval Guide, Building Materials" for Class 1 fire rating and Class 1-90 windstorm ratings.

1.05 DELIVERY, STORAGE, AND HANDLING

- A. Protect steel deck from corrosion, deformation, and other damage during delivery, storage, and handling.
- B. Stack steel deck on platforms or pallets and slope to provide drainage. Protect with a waterproof covering and ventilate to avoid condensation.
 - 1. Protect and ventilate acoustical cellular roof deck with factory-installed insulation to maintain insulation free of moisture.

PART 2 - PRODUCTS

2.01 PERFORMANCE REQUIREMENTS

- A. AISI Specifications: Comply with calculated structural characteristics of steel deck according to AISI's "North American Specification for the Design of Cold-Formed Steel Structural Members."
- B. Fire-Resistance Ratings: Comply with ASTM E 119; testing by a qualified testing agency. Identify products with appropriate markings of applicable testing agency.
 - 1. Indicate design designations from UL's "Fire Resistance Directory" or from the listings of another qualified testing agency.

2.02 ROOF DECK

- A. Roof Deck: Fabricate panels, without top-flange stiffening grooves, to comply with "SDI Specifications and Commentary for Steel Roof Deck," in SDI Publication No. 31, and with the following:

1. **Prime-Painted Steel Sheet:** ASTM A 1008/A 1008M, Structural Steel (SS), Grade 40 (275) minimum, shop primed with manufacturer's standard baked-on, rust-inhibitive primer.
 - a. **Color:** Manufacturer's standard.
2. **Galvanized-Steel Sheet:** ASTM A 653/A 653M, Structural Steel (SS), Grade 40 (275), G90 (Z180) zinc coating.
3. **Galvanized and Shop-Primed Steel Sheet:** ASTM A 653/A 653M, Structural Steel (SS), Grade 40 (275), G60 (Z180) zinc coating; cleaned, pretreated, and primed with manufacturer's standard baked-on, rust-inhibitive primer.
 - a. **Color:** Manufacturer's standard.
4. **Aluminum-Zinc-Alloy-Coated Steel Sheet:** ASTM A 792/A 792M, Structural Steel (SS), Grade 33 (230) minimum, AZ50 (AZ150) aluminum-zinc-alloy coating.
5. **Deck Profile:** As indicated.
6. **Profile Depth:** As indicated.
7. **Design Uncoated-Steel Thickness:** As indicated.
8. **Span Condition:** Triple span or more.
9. **Side Laps:** Overlapped.

2.03 NONCOMPOSITE FORM DECK

- A. **Noncomposite Form Deck:** Fabricate ribbed-steel sheet noncomposite form-deck panels to comply with "SDI Specifications and Commentary for Noncomposite Steel Form Deck," in SDI Publication No. 31, with the minimum section properties indicated, and with the following:
 1. **Uncoated Steel Sheet:** ASTM A 1008/A 1008M, Structural Steel (SS), Grade 40 (275) minimum.
 2. **Galvanized-Steel Sheet:** ASTM A 653/A 653M, Structural Steel (SS), Grade 40 (275) G90 (Z180) zinc coating.
 3. **Profile Depth:** 1-1/2 inches (38 mm).
 4. **Design Uncoated-Steel Thickness:** As indicated.
 5. **Span Condition:** Triple span or more.
 6. **Side Laps:** Overlapped.

2.04 ACCESSORIES

- A. **General:** Provide manufacturer's standard accessory materials for deck that comply with requirements indicated.
- B. **Mechanical Fasteners:** Corrosion-resistant, low-velocity, power-actuated or pneumatically driven carbon-steel fasteners; or self-drilling, self-threading screws.
- C. **Side-Lap Fasteners:** Corrosion-resistant, hexagonal washer head; self-drilling, carbon-steel screws, No. 10 (4.8-mm) minimum diameter.
- D. **Flexible Closure Strips:** Vulcanized, closed-cell, synthetic rubber.

- E. **Miscellaneous Sheet Metal Deck Accessories:** Steel sheet, minimum yield strength of 33,000 psi (230 MPa), not less than 0.0359-inch (0.91-mm) design uncoated thickness, of same material and finish as deck; of profile indicated or required for application.
- F. **Pour Stops and Girder Fillers:** Steel sheet, minimum yield strength of 33,000 psi (230 MPa), of same material and finish as deck, and of thickness and profile recommended by SDI Publication No. 31 for overhang and slab depth.
- G. **Column Closures, End Closures, Z-Closures, and Cover Plates:** Steel sheet, of same material, finish, and thickness as deck unless otherwise indicated.
- H. **Piercing Hanger Tabs:** Piercing steel sheet hanger attachment devices for use with floor deck.
- I. **Flat Sump Plates:** Single-piece steel sheet, 0.0747 inch (1.90 mm) thick, of same material and finish as deck. For drains, cut holes in the field.
- J. **Recessed Sump Pans:** Single-piece steel sheet, 0.0747 inch (1.90 mm) thick, of same material and finish as deck, with 3-inch- (76-mm-) wide flanges and level recessed pans of 1-1/2-inch (38-mm) minimum depth. For drains, cut holes in the field.
- K. **Galvanizing Repair Paint:** SSPC-Paint 20 or MIL-P-21035B, with dry film containing a minimum of 94 percent zinc dust by weight.
- L. **Repair Paint:** Manufacturer's standard rust-inhibitive primer of same color as primer.

PART 3 - EXECUTION

3.01 EXAMINATION

- A. Examine supporting frame and field conditions for compliance with requirements for installation tolerances and other conditions affecting performance.
- B. Proceed with installation only after unsatisfactory conditions have been corrected.

3.02 INSTALLATION, GENERAL

- A. Install deck panels and accessories according to applicable specifications and commentary in SDI Publication No. 31, manufacturer's written instructions, and requirements in this Section.
- B. Install temporary shoring before placing deck panels if required to meet deflection limitations.
- C. Locate deck bundles to prevent overloading of supporting members.
- D. Place deck panels on supporting frame and adjust to final position with ends accurately aligned and bearing on supporting frame before being permanently fastened. Do not stretch or contract side-lap interlocks.
 - 1. Align cellular deck panels over full length of cell runs and align cells at ends of abutting panels.
- E. Place deck panels flat and square and fasten to supporting frame without warp or deflection.

- F. Cut and neatly fit deck panels and accessories around openings and other work projecting through or adjacent to deck.
- G. Provide additional reinforcement and closure pieces at openings as required for strength, continuity of deck, and support of other work.
- H. Comply with AWS requirements and procedures for manual shielded metal arc welding, appearance and quality of welds, and methods used for correcting welding work.
- I. Mechanical fasteners may be used in lieu of welding to fasten deck. Locate mechanical fasteners and install according to deck manufacturer's written instructions.

3.03 FIELD QUALITY CONTROL

- A. Testing Agency: Owner will engage a qualified testing agency to perform tests and inspections.
- B. Field welds will be subject to inspection.
- C. Testing agency will report inspection results promptly and in writing to Contractor and Architect.
- D. Remove and replace work that does not comply with specified requirements.
- E. Additional inspecting, at Contractor's expense, will be performed to determine compliance of corrected work with specified requirements.

3.04 PROTECTION

- A. Galvanizing Repairs: Prepare and repair damaged galvanized coatings on both surfaces of deck with galvanized repair paint according to ASTM A 780 and manufacturer's written instructions.
- B. Repair Painting: Wire brush and clean rust spots, welds, and abraded areas on both surfaces of prime-painted deck immediately after installation, and apply repair paint.
 1. Apply repair paint, of same color as adjacent shop-primed deck, to bottom surfaces of deck exposed to view.
 2. Wire brushing, cleaning, and repair painting of bottom deck surfaces are included in Section 099113 "Exterior Painting" and Section 099123 "Interior Painting."
- C. Repair Painting: Wire brushing, cleaning, and repair painting of rust spots, welds, and abraded areas of both deck surfaces are included in Section 099113 "Exterior Painting" and Section 099123 "Interior Painting."
- D. Provide final protection and maintain conditions to ensure that steel deck is without damage or deterioration at time of Substantial Completion.

3.05 PAYMENT

- A. Lump sum price for Bus Pavilion and Architectural Construction Maintenance Building covers all items of work in this Special Provision including furnishing labor, materials, tools, equipment, and incidentals required to complete the work.

END OF SECTION

State Road and Tollway Authority (SRTA), State of Georgia

SPECIAL PROVISION

Section 763 – Bus Pavilion and/or Section 999 – Architectural Construction Maintenance Building

Section 061000 – Rough Carpentry

PART 1 – GENERAL

1.01 WORK INCLUDED

- A. Types of work in this Section include, but are not limited to, rough carpentry for:
1. Wood grounds, nailers, and blocking.
 2. Plywood backing.
 3. Decay and termite resistant wood treatment.
 4. Fire resistant wood treatment. (Equipment room walls)

1.02 RELATED WORK

- A. CONCRETE UNIT MASONRY: Section 04 22 00.
- B. SBS MODIFIED BITUMINOUS ROOFING MEMBRANE: Section 07 52 16.

1.03 QUALITY ASSURANCE

- A. Reference Standards: Comply with provisions of the following, unless otherwise indicated or specified:
1. American Forest & Paper Association (AFPA):
 - a. Manual for Wood Frame Construction.
 2. American Lumber Standards Committee (ALSC):
 - a. Board of Review.
 3. APA - The Engineered Wood Association (APA):
 - a. APA Standard Grading Rules.
 - b. Form No. E30K - APA Design/Construction Guide: Residential & Commercial.
 4. American Society for Testing and Materials (ASTM):

SPECIAL PROVISION SECTION 763 – BUS PAVILION AND/OR
SECTION 999 – ARCHITECTURAL CONSTRUCTION MAINTENANCE BUILDING
ROUGH CARPENTRY

1

- a. **Reference Standards.**
 - 5. **American Wood Preservers' Association (AWPA):**
 - a. **Reference Standards.**
 - 6. **Federal Specifications (FS):**
 - a. **Reference Standards.**
 - 7. **U.S. Department of Commerce (DOC), National Institute of Standards and Technology:**
 - a. **Referenced Product Standards (PS).**
 - 8. **Southern Pine Inspection Bureau (SPIB):**
 - a. **SPIB Standard Grading Rules.**
 - 9. **West Coast Lumber Inspection Bureau (WCLIB):**
 - a. **WCLIB Standard Grading Rules.**
 - 10. **Western Wood Products Association (WWPA):**
 - a. **WWPA Standard Grading Rules.**
 - b. **Recommended Nailing Schedule.**
- 1.04 **SUBMITTALS**
- A. **Product Data for Treated Lumber:** Submit treatment plant's data showing the lumber type, certification by the treating plant stating chemicals and process used, net amount of treatment retained, and conformance with applicable standards. Include a statement that moisture content of treated materials was reduced to a maximum of 19 percent prior to shipment to the Site.
- 1.05 **PRODUCT DELIVERY, STORAGE AND HANDLING**
- A. Maintain materials under cover and dry. Protect against exposure to weather and contact with damp or wet surfaces. Stack lumber as well as plywood and other panels; provide for air circulation within and around stacks and under temporary coverings including polyethylene and similar materials.
 - B. For lumber and plywood pressure treated with waterborne chemicals, provide space between each course to provide air circulation.
- 1.06 **PROJECT CONDITIONS**
- A. **Coordination:** Fit carpentry work to other work; scribe and cope as required for accurate fit. Correlate location of furring, nailers, plates, blocking, grounds and similar supports to allow attachment of other work.

PART 2 – PRODUCTS**2.01 MATERIALS****A. Lumber Standards, General:**

1. Manufacture lumber to comply with **DOC PS 20 "American Softwood Lumber Standard"** and with applicable grading rules of inspection agencies certified by **ALSC Board of Review**.
2. **Factory mark** each piece of lumber with grade stamp of inspection agency evidencing compliance with grading rule requirements and identifying grading agency, grade species, moisture content at time of surfacing, and mill.
3. Nominal sizes are indicated, except as shown by detail dimensions. **Provide actual sizes** as required by **DOC PS 20**, for moisture content specified for each use.
4. **Provide seasoned lumber** with 19 percent maximum moisture content at time of dressing and shipment for sizes 2 inches or less in nominal thickness, unless otherwise indicated.

B. Grounds, Blocking, Nailers, Blocking, and Similar Members:

1. Grounds, nailers, blocking, and similar members shall be standard grade light framing size lumber of any species or board size lumber as required. No. 2 Common or Standard grade boards per **WCLIB** or **WWPA** rules, or No. 2 boards per **SPIB** rules.

C. Plywood Panels:

1. Comply with **DOC PS 1 "U.S. Product Standard for Construction and Industrial Plywood"** for plywood panels and, for products not manufactured under **PS 1** provisions, with **APA Form No. E30K**.
2. **Factory mark** each construction panel with **APA** trademark evidencing compliance with grade requirements.

D. Fasteners and Anchorages:

1. **Provide size, type, material, and finish** as indicated and as recommended by applicable standards, complying with applicable **Federal Specifications** for nails, staples, screws, bolts, nuts, washers, and anchoring devices. **Provide metal hangers and framing anchors** of the size and type recommended by the manufacturer for each use including recommended nails.
2. Where rough carpentry is exposed to weather, in ground contact, or in area of high relative humidity, provide fasteners and anchorages with a hot-dip zinc coating pursuant to **ASTM A 153**.

E. Decay and Termite Resistant Wood Treatment:

1. All lumber and plywood specified for decay and termite resistant treatment shall be pressure treated according to **AWPA Standard P-5** and **FS TT-W-550**. Preservatives containing arsenic are **NOT** acceptable.
2. **Products:** Provide one of the following treatments:

**SPECIAL PROVISION SECTION 763 – BUS PAVILION AND/OR
SECTION 999 – ARCHITECTURAL CONSTRUCTION MAINTENANCE BUILDING
ROUGH CARPENTRY**

3

- a. "Natural Select" copper azole preservative; Arch Wood Protection, Inc.
- b. "Preserve" ACQ; Chemical Specialties, Inc.
- c. "NatureWood"; Osmose, Inc.

F. Fire Resistant Wood Treatment:

- 1. All lumber and plywood specified for fire resistant treatment shall be pressure impregnated with fire retardant products. Such products shall not subject the wood to deterioration when exposed to heat and humidity.
- 2. Products: provide one of the following treatments:
 - a. "Pyro-Guard"; Hoover Treated Wood Products.
 - b. "Osmose Flame Proof"; Osmose Wood Preserving Co., Inc.

2.02 WOOD TREATMENT

A. Decay and Termite Resistant Wood Treatment: Chemicals shall be applied in a closed cylinder by vacuum-pressure process in strict accordance with manufacturer's instructions and with the approved standards and recommended treating practices as listed in AWPA Standards C2 and C9 or the appropriate AWPA standard covering the commodity treated and as listed in FS TT-W-571.

- 1. After treatment and before shipment, lumber 2" nominal or less shall be dried to a 15-19 percent moisture content.
- 2. Plywood shall be dried after treatment and before shipment to moisture content of 18 percent or less.

B. Fire Resistant Wood Treatment:

- 1. Chemicals shall be applied in a closed cylinder by vacuum-pressure in strict accordance with manufacturer's instructions to comply with the requirement for a flame spread of 25 or less with no evidence of significant progressive combustion when tested for 30 minutes duration under the standard test method for Fire Hazard Classification of Building Materials; ASTM E 84; UL 723 and; AWPA C20 and AWPA C27.
- 2. Each piece of wood shall bear the mark of Underwriters' Laboratories FR-S label, indicating compliance with the fire hazard classification.
- 3. After treatment and before shipment, all fire treated wood shall be dried to an average moisture content of 19 percent or less.
- 4. Surfaces of wood that are to be exposed or painted shall be free from sludge or deposits of salts that would affect its paintability.

C. Provide decay (termite) and fire treatment of the following lumber:

<u>Location – Equipment Room</u>	<u>Treatment (General)</u>
----------------------------------	----------------------------

14

Wood members in contact with concrete, used in connection with roofing, furring for interior plywood panels on ceiling and walls, or exposed to moisture

Decay (Termite)

Plywood backing panels for mounting toll equipment, electrical and telephone equipment

Fire (Non-Corrosive Chemicals)

PART 3 – EXECUTION

3.01 INSPECTION

- A. Examine the areas and conditions under which rough carpentry work is to be installed. Do not proceed with rough carpentry work until unsatisfactory conditions have been corrected.

3.02 INSTALLATION

A. General:

1. Material with defects, which might impair the quality of the work, and units which are too small to fabricate with a minimum of joints or the optimum joint arrangement, shall be discarded.
2. All rough carpentry work shall be set accurately to required levels and lines, with members plumb and true, and accurately cut and fitted.
3. All rough carpentry work shall be securely attached to substrates by anchoring and fastening as shown, and as required for structural adequacy.
4. Fasteners shall be of size that will not penetrate members where opposite side will be exposed to view or will receive finish materials. Tight connections shall be made. Fasteners shall be installed without splitting of wood; predrill as required.
5. Use washers where required for fasteners to avoid movement of material through loading and/or vibration.
6. Seal cut ends where exposed to moisture or where moisture could migrate via gravity, capillary action, expansion or pressure gradients.

B. Wood Grounds, Nailers, and Blocking:

1. Wood grounds, nailers, and blocking shall be installed where indicated on the Drawings, and wherever required for screeding or attachment of other work. Shapes shall be formed as shown and cut as required for true line and level of work to be attached.
2. Attach to substrates as required to support applied loading. Countersink bolts and nuts flush with surfaces, unless otherwise indicated. Build into masonry during installation of masonry work. Where possible, anchor to formwork prior to concrete placement.

C. Plywood Panels:

1. Comply with applicable recommendations contained in APA Form No. E 30K for types of plywood panels and applications indicated.

SPECIAL PROVISION SECTION 763 – BUS PAVILION AND/OR
SECTION 999 – ARCHITECTURAL CONSTRUCTION MAINTENANCE BUILDING
ROUGH CARPENTRY

5

2. **Fastening Methods:** Fasten panels as follows, in strict accordance with the Florida Building Code:
 - a. **Backing Panels:** Screw to supports.

3.03 **PAYMENT**

- A. Lump sum price for Bus Pavilion and Architectural Construction Maintenance Building covers all items of work in this Special Provision including furnishing labor, materials, tools, equipment, and incidentals required to complete the work.

END OF SECTION

State Road and Tollway Authority (SRTA), State of Georgia

SPECIAL PROVISION

Section 999 – Architectural Construction Maintenance Building

Section 072100 – Thermal Insulation

PART 1 – GENERAL

1.01 WORK INCLUDED

- A. Provide rigid insulation on interior face of exterior walls and equipment room ceiling as indicated on Drawings and specified herein.

1.02 RELATED WORK

- A. COLD FORMED METAL FRAMING: Section 05 40 00.

1.03 SUBMITTALS

- A. Submit samples and product data for each type of insulation.

1.04 PRODUCT HANDLING, DELIVERY, AND STORAGE

- A. Deliver products in unopened containers. Provide adequate storage.
- B. Deliver materials to the job site in original unopened packages, clearly marked with product brand name and manufacturer's labels. Store under cover and protect from weather and construction activities.

PART 2 – PRODUCTS

2.01 MATERIALS

- A. **Extruded Polystyrene Board Insulation:** Rigid cellular polystyrene thermal insulation manufactured with closed cells formed by the expansion of polystyrene base resin in an extrusion process complying with ASTM C 578, Type IV; Aged R-value of 5 for 1-inch thickness at 75 degrees F; in manufacturer's standard lengths and widths to suit installation conditions. Designed to be easily fit between wood furring members.

1. **Products:** Provide one of the following insulation products:

- a. "Styrofoam Score Board"; Dow Chemical Company.
- b. "Amofoam - SB"; Tenneco Building Products.

PART 3 – EXECUTION

3.01 INSTALLATION

- A. Install insulation in strict accordance with manufacturer's published instructions.

3.02 PAYMENT

- A. Lump sum price for Architectural Construction Maintenance Building covers all items of work in this Special Provision including furnishing labor, materials, tools, equipment, and incidentals required to complete the work.

END OF SECTION

State Road and Tollway Authority (SRTA), State of Georgia

SPECIAL PROVISION

Section 763 – Bus Pavilion and/or Section 999 – Architectural Construction Maintenance Building

Section 072600 – Vapor Barrier

PART 1 – GENERAL

1.01 WORK INCLUDED

- A. Furnish and install an under-slab vapor barrier located under all concrete floor slabs, including walks within building line, as indicated on the Drawings and specified herein.

1.02 RELATED WORK

- A. CONCRETE FORMING AND ACCESSORIES: Section 03 10 00.

1.03 SUBMITTALS

- A. Product Data: Submit manufacturer's published descriptive literature, including typical details and installation instructions, for vapor barrier membrane, mastic, and tape.
- B. Samples: Submit three (3) 12-inch by 12-inch samples of vapor barrier membrane and 6-inch length samples of tape.

1.04 DELIVERY AND STORAGE

- A. Packaged Materials: Deliver materials in bundles, rolls, and sealed containers bearing the manufacturer's original labels. Store materials in an enclosed area free from contact with soil and weather, and maintain at not less than 50 degrees F for at least 24 hours before use. If material is dated for use or "shelf life" is indicated on the labels, all outdated material shall be removed from the Site.

PART 2 – PRODUCTS

2.01 VAPOR BARRIER MATERIALS

- A. Vapor Barrier Membrane: Comply with the following:
 1. Membrane Material: Flexible plastic or plastic laminate membrane, minimum 8.0 mils in thickness.
 2. Products: Provide one of the following vapor barrier membranes:
 - a. "Nervastral"; Nervastral, Inc.

SPECIAL PROVISION SECTION 763 – BUS PAVILION AND/OR
SECTION 999 – ARCHITECTURAL CONSTRUCTION MAINTENANCE BUILDING
VAPOR BARRIER

1

- b. "Fiberweb 210 Underslab Vapor Barrier"; Fiberweb Division of Hammerbeam, Inc.
 - c. "Moistop Underslab"; Fortiber Building Products.
 - d. "Griffolyn Type 65G"; Reef Industries.
- B. Mastic: Comply with the following:
- 1. Provide mastic compound as recommended by the membrane manufacturer.
- C. Tape: Double-sided pressure sensitive tape with release paper. Suitable as a durable field seam around penetrations in the vapor barrier membrane and to join membrane sheets together

PART 3 – EXECUTION

3.01 INSPECTION

- A. Examine the areas and conditions under which the under-slab vapor barrier is to be installed. Do not proceed with vapor barrier work until unsatisfactory conditions have been corrected.

3.02 APPLICATION

- A. Apply directly to compacted earth base, under concrete slabs, one layer of the vapor barrier membrane. Maintain 6 inch side laps and 9 inch end laps; turn down membrane 12 inches at slab/wall intersections.
- B. Laps shall be fully sealed with mastic in strict accordance with manufacturer's published instructions for application procedures and limitations for temperature and setting time.
- C. Additional strips shall be used at penetrations of membrane to close openings in membrane. Set in mastic.
- D. Extreme care and precaution shall be exercised after membrane has been applied to prevent punctures, tears, and other abuses. Should such vapor barrier damage occur, repair the membrane by application of a membrane patch, sized to lap 9 inches on all sides of the damaged area, and set in a full bed of mastic.

3.03 PAYMENT

- A. Lump sum price for Bus Pavilion and Architectural Construction Maintenance Building covers all items of work in this Special Provision including furnishing labor, materials, tools, equipment, and incidentals required to complete the work.

END OF SECTION

SPECIAL PROVISION SECTION 763 – BUS PAVILION AND/OR
SECTION 999 – ARCHITECTURAL CONSTRUCTION MAINTENANCE BUILDING
VAPOR BARRIER

2

State Road and Tollway Authority (SRTA), State of Georgia

SPECIAL PROVISION

Section 763 – Bus Pavilion and/or Section 999 – Architectural Construction Maintenance Building

Section 074100 – Formed Metal Roofing

PART 1 - GENERAL

1.1 WORK INCLUDED

- A. Extent of each type of formed metal roofing is indicated on the drawings and by provisions of this section. Formed metal roofing is hereby defined to include panels which are architectural (non-structural).
- B. Types of panels required include the following:
 - 1. Formed prefinished galvalume sheet panels, intended for standing-seam roof installation with concealed fastening including all related fasciae, trims, flashing accessories, and fasteners.
 - 2. Alternative Material: Provide a minimum of 0.32 Aluminum Panels in lieu of 22 gauge steel panels. Paint warranty shall not include Marine atmosphere and salt or fresh air exclusion.

1.2 QUALITY ASSURANCE

- A. Performance Test Standards: Provide formed panel systems which have been pretested and certified by manufacturer to provide specified resistance to air and water infiltration and structural deflection and failure when installed as indicated and when tested in accordance with ASTM E-331-6 and E283-84. Comply with International Building Code, latest edition, 140 mph wind loading uplift.
- B. Field Measurements: Where possible, prior to fabrication of sheet metal panels, take field measurements of structure or substrates to receive panel system. Allow for trimming panel units where final dimensions cannot be established prior to fabrication.
- C. Solar Reflectance Index: Not less than 29 when calculated according to ASTM E 1980 based on identical projects by a qualified testing agency.

1.3 SUBMITTALS

- A. Product Data: Submit manufacturer's product specifications, standard details, certified product test results, installation instructions and general recommendations, as applicable

SPECIAL PROVISION SECTION 763 – BUS PAVILION AND/OR
SECTION 999 – ARCHITECTURAL CONSTRUCTION MAINTENANCE BUILDING
FORMED METAL ROOFING

1

to materials and finishes for each component and for total system of preformed panels, including sample warranty documents.

- B. Samples: Submit sample of 12-inch square, of each exposed finish material.
- C. Shop Drawings: Submit small-scale layouts of panels on roofs, and large-scale details of edge conditions, joints, corners, custom profiles, supports, anchorages, trim, flashings, closures, and special details, including ridge vents. Distinguish between factory and field assembly work.
- D. Water Tightness Warranty
 - 1. Manufacturer's standard form in which manufacturer agrees to repair or replace standing-steam metal roof panel assemblies, installed to manufacturer detail and specification, that fail to remain weathertight, including leaks, within specified warranty period.
 - a. Warranty Period: 20 years from date of Substantial Completion.
- E. Warranty
 - 1. Manufacturer shall warrant the metal roof against rupture or perforation or from structurally failing due to normal atmospheric conditions for a period of 25 years. In addition, manufacturer shall provide a 35-year finish warranty against peeling and blistering, chalk, and fade (color change).
 - 2. Installer shall provide a written warranty for 2 years from the date of final completion and acceptance, guaranteeing materials and workmanship for watertightness and watertightness of the roof, without any cost to the building owner.
- F. Panels shall be continuous length ridge to eave. No lap joints will be permitted.

PART 2 - PRODUCTS

2.1 SHEET MATERIALS

- A. Roof Panels: Prefinished galvalume sheet steel, 22 gauge, conforming to ASTM 792-86.
 - 1. Panels shall have minimum of 12 inches to 16 inches o.c. seam spacing. Panels and seams shall be roll formed in continuous lengths.
 - 2. Provide a minimum 2-inch double lock panel approved by International Building Code for negative pressure required for building site when tested in accordance with ASTM E 331-6 and E283-84.
 - 3. Panel assembly to bear compliance with International Building Code, latest edition.

2.2 METAL FINISHES

- A. General: Apply coatings either before or after forming and fabricating panels, as required by coating process and as required for maximum coating performance capability. Protect

SPECIAL PROVISION SECTION 763 – BUS PAVILION AND/OR
SECTION 999 – ARCHITECTURAL CONSTRUCTION MAINTENANCE BUILDING
FORMED METAL ROOFING

2

coating promptly after application and cure, by application of strippable film or removable adhesive cover, and retain until installation has been completed.

- B. Fluoropolymer Coating:** Full-strength premium fluorocarbon coating applied to sheets with a top side film thickness of 0.70 to 0.90 mil over 0.25 to 0.31 mil prime coat to provide a total dry film thickness of 0.95 to 1.25 mil. Bottom side of sheets to be coated with a primer with a dry film thickness of 0.25 mil.
1. **Durability:** Provide coating which has been field tested under normal range of weathering conditions for minimum of 20 years without significant peel, blister, flake, chip, crack or check and without fading in excess of 5 NBS units.
 2. **Color:** Color to be selected from manufacturer's colors based on the Authority's standard color palette.

2.3 MISCELLANEOUS MATERIALS

- A. Fasteners:** Manufacturer's standard noncorrosive concealed fastening, allowing for thermal movement of roof panels.
- B. Accessories:** Except as indicated as work of another Technical Special Provision section, provide components required for a complete roofing system, including trim, fasciae, corner units, ridge vent closures, clips, seam covers, battens, flashing, sealants, gaskets, fillers, closure strips and similar items. Match materials/finishes of preformed panels.
- C. Underlayment:** Provide one layer of 40 mils. self-adhered roofing underlayment conforming to the requirements of ASTM D3767 Method A, Tensile Strength ASTM 412, Adhesion ASTM E 96 and material weight ASTM D461.

2.4 PANEL FABRICATION; PERFORMANCES

- A. General:** Fabricate and finish panels and accessories at the factory to greatest extent possible, by manufacturer's standard procedures and processes, and as required to fulfill indicated performance requirements which have been demonstrated by factory testing. Comply with indicated profiles and dimensional requirements, and with structural requirements.
- B. Metal Gages:** Thicknesses required for structural performances, but not less than manufacturer's recommended minimums for profiles and applications indicated, and in no case less than 22 gauge.
- C. Required Performances:** Fabricate panels and other components of roof system for loads indicated on the drawings:
1. **Water Penetration:** No significant, uncontrolled leakage at 4 lbs. per square foot pressure with spray test.
 2. **Air Infiltration:** 0.02 cgm per sq. foot for gross roof/wall areas, with 4 lbs. per square foot differential pressure.
- D. Fabricate double-loc 2-inch-high metal panels meeting requirements approved by the International Building Code.**

- E. Condensation: Fabricate panels for control of condensation, including vapor inclusion of seals and provisions for breathing, venting, weeping and draining.

PART 3 - EXECUTION

3.1 INSTALLATION

- A. General: Comply with panel fabricator's and material manufacturers' instructions and recommendations for installation, as applicable to project conditions and supporting substrates. Anchor panels and other components of the work securely in place, with provisions for thermal/structural movement.
- B. Install one layer of 40 m/l self-adhered underlayment laid and lapped horizontally starting at the eave.
- C. Accessories: Install components required for a complete roof panel system including trim, copings, fasciae, corner units, ridge closures, clips, seam corners, flashings, sealants, gaskets, fillers, closure strips, and similar items.
- D. Joint Sealers: Install gaskets, joint fillers, and sealants where indicated and where required for weatherproof performance of panel systems. Provide types of gaskets and sealants/fillers indicated or, if not otherwise indicated, types recommended by panel manufacturer.

3.2 CLEANING AND PROTECTION

- A. Damaged Units: Replace panels and other components of the work which have been damaged or have deteriorated beyond successful repair by means of finish touch-up or similar minor repair procedures.
- B. Cleaning: Remove temporary protective coverings and strippable films (if any) as each panel is installed. Upon completion of panel installation, clean finished surfaces as recommended by panel manufacturer, and maintain in a clean condition during construction.

3.3 PAYMENT

- A. Lump sum price for Bus Pavilion and Architectural Construction Maintenance Building covers all items of work in this Special Provision including furnishing labor, materials, tools, equipment, and incidentals required to complete the work.

END OF SECTION

State Road and Tollway Authority (SRTA), State of Georgia

SPECIAL PROVISION

Section 763 – Bus Pavilion and/or Section 999 – Architectural Construction Maintenance Building

Section 075216 – SBS Modified Bituminous Membrane Roofing

PART 1 – GENERAL

1.01 SUMMARY

- A. Furnish and install a multiple ply SBS modified bitumen roofing system, including composition flashing and stripping, and roofing accessories, as indicated on the Drawings and specified herein.
- B. Sheet metal materials included as work of this Section are specified as indicated on the Drawings.

1.02 RELATED WORK

- A. CONCRETE FORMING AND ACCESSORIES: Section 03 10 00.
- B. METAL FABRICATIONS: Section 05 50 00.
- C. ROUGH CARPENTRY: Section 06 10 00.

1.03 QUALITY ASSURANCE

- A. Installer's Qualifications: A single Installer, with a minimum of five years successful documented experience, with at least five (5) roofs installed using roofing systems similar to that required for this Project.
 - 1. Installer must be approved by the roofing system membrane manufacturer prior to bidding and throughout the life of the installation. Submit evidence of this approval.
- B. Manufacturer's Qualifications:
 - 1. Minimum of ten (10) years documented experience manufacturing SBS modified bitumen roofing membranes.
 - 2. Provide a factory trained representative whose sole responsibility is field technical rooftop support. The duties and responsibilities of this representative are as follows:
 - a. To be present at the pre-application roofing conference, membrane installation commencement, and for intermediate inspections at appropriate completion stages. The representative shall also provide a two-stage final inspection comprised of the initial stage and the subsequent second inspection to verify that all final construction inspection punch list items have been satisfactorily completed.

- b. To submit a written report corresponding to each required visit within seven (7) calendar days following the date of the visit.
- c. The representative shall be the same individual for the entire duration of the roofing installation, unless otherwise acceptable to the Authority.

C. Pre-Application Roofing Conference:

1. Approximately two (2) weeks prior to scheduled commencement of the roofing installation, arrange to meet at the Project site with the following entities: SRTA, roofing Installer, roofing system manufacturer's representative, and other entities directly concerned with performance of the Work.
2. Record discussions of conference and decisions and agreements or disagreements reached and furnish copy of record to each party attending within seven (7) calendar days following the date of the meeting.
3. Review foreseeable methods and procedures related to roofing work including, but not limited to, the following:
 - a. Tour representative areas of roofing substrates (deck); inspect and discuss condition of substrate, drain sumps, parapet walls, curbs, penetrations and other preparatory work.
 - b. Review roofing system requirements (Contract Documents containing Drawings and Specifications).
 - c. Review required submittals, both completed and yet to be completed.
 - d. Review and finalize construction schedule and verify availability of materials, Installer's personnel, equipment and facilities needed to make progress and avoid delays.
 - e. Review required inspection, testing, certifying and material usage procedures.

D. Codes and Standards: Comply with provisions of referenced codes and standards for the following, unless otherwise indicated or specified:

1. American Society for Testing and Materials (ASTM).
2. Factory Mutual Global (FMG).
3. Federal Specifications (FS).
4. National Roofing Contractor's Association (NRCA).
5. Sheet Metal and Air Conditioning Contractor's National Association (SMACNA).
6. International Building Code.
7. Underwriters' Laboratories, Inc. (UL).

1.04 PERFORMANCE CRITERIA

- A. **UL Class A Roof System requirements and FMG Class I Roof System for 1-90 Wind Uplift requirements in FMG Loss Prevention Data Sheet 1-28, "Wind Loads to Roof Systems and Roof Deck Securement."**
- B. **Provide roof covering materials bearing UL Classification Marking on bundle, package and/or container indicating that materials have been produced under UL's Classification and Follow-up Service.**
- C. **Comply with the following testing procedures:**
 - 1. **Equal to Florida Building Code Test Protocol TAS 105-Test Procedure for Field Withdrawal Resistance Testing.**
 - 2. **Equal to Florida Building Code Test Protocol TAS 114-Test Procedures for Roof System as the High Velocity Hurricane Zone Jurisdiction.**
 - a. **Appendix A- Test Procedure for Above Deck Combustibility ASTM E 108.**
 - b. **Appendix C-Test Procedure for Simulated Uplift Pressure Resistance of Roof System Assemblies.**
 - c. **Appendix E-Test Procedure for Corrosion Resistance of Fasteners, Batten Bars and Stress Distribution Plates.**
 - d. **Appendix F-Test Procedure for Susceptibility to Hail Damage for Roof Systems Assemblies.**

1.05 SUBMITTALS

- A. **Product Data:** Submit manufacturer's technical product data, installation instructions and current recommendations for each type of roofing product required. Include data substantiating that materials comply with specified requirements.
 - 1. **Provide Material Safety Data Sheets for roofing system components.**
- B. **Shop Drawings:** Submit shop drawings indicating as a minimum, the following:
 - 1. **Typical flashing details for all structures.**
- C. **Samples:** Submit three (3) samples each of the following products:
 - 1. **12 inch by 12 inch square of type of membrane and flashing ply.**
- D. **Installer Certificates:** Signed by roofing system manufacturer certifying that Installer is approved, authorized, or licensed by manufacturer to install specified roofing system and is eligible to receive the standard roofing manufacturer's warranty.
- E. **Manufacturer Certificates:** Signed by roofing manufacturer certifying that the roofing system complies with all performance requirements specified in this Section. Upon request, submit evidence of complying with requirements.

1. Manufacturer also to review Drawings and Specifications for suitability of membrane system specified with Project conditions and certify suitability in writing.
- F. **Product Test Reports:** Based on evaluation of tests performed by manufacturer and witnessed by a qualified independent testing agency, indicate compliance of components of roofing system with requirements based on comprehensive testing of current product compositions.
1. Indicate compliance of bulk roofing asphalt materials delivered to Project with requirements. Include quantity and statistical and descriptive data for each product. Submit certificate with each load before it is used.
 2. Include continuous log showing time and temperature for each load of bulk bitumen, indicating date obtained from manufacturer, where held, and how transported before final heating and application on roof.
- G. **Research/Evaluation Reports:** Evidence of roofing system's compliance with building code in effect for Project, from a model code organization acceptable to authorities having jurisdiction.
- H. **Maintenance Data:** For roofing system to include in maintenance manuals.
- I. **Warranty:** Sample copy of standard roofing system manufacturer's warranty stating obligations, remedies, limitations, and exclusions of warranty.
- J. **Inspection Report:** Copy of roofing system manufacturer's inspection report of completed roofing installation.
- K. **Manufacturer's Qualifications:**
1. Submit manufacturer's qualification.

1.06 DELIVERY, STORAGE, AND HANDLING

- A. Store roofing materials in a dry, well-ventilated, weathertight location to ensure no significant moisture pickup and maintain at a temperature exceeding roofing system manufacturer's written instructions. Store rolls of felt and other sheet materials on end on pallets or other raised surfaces. Do not double-stack rolls.
1. Handle and store roofing materials and place equipment in a manner to avoid significant or permanent damage to deck or structural supporting members.
- B. Do not leave unused felts and other sheet materials on the roof overnight or when roofing work is not in progress unless protected from weather and moisture and unless maintained at a temperature exceeding 50 deg F.
- C. Deliver and store liquid materials in their original undamaged containers in a clean, dry, protected location and within the temperature range required by roofing system manufacturer.

1.07 PROJECT CONDITIONS

- A. **Environmental Requirements:** Proceed with roofing work only when existing and forecasted weather conditions will permit work to be performed in accordance with manufacturer's recommendations and warranty requirements.

1.08 WARRANTY

- A. **Manufacturer's Roofing Warranty:** Provide roofing membrane manufacturer's premium No Dollar Limit (NDL) Warranty agreement including flashing endorsement, signed by an authorized representative of roofing system manufacturer, on form which was published as of date of Contract Documents.
 - 1. Flashing endorsement to, but not by way of limitation, the manufactured coping specified in Section 07 71 00 – ROOF SPECIALTIES.
 - 2. **Warranty Duration:** Twenty (20) years from the date of Final Acceptance.

PART 2 – PRODUCTS**2.01 ROOFING SYSTEM DESIGN**

- A. Provide the roof system designs specified herein.
 - 1. System "D": "System 2448"; Soprema Roofing and Waterproofing, Inc. (Soprema).

2.02 ROOFING SYSTEM DESCRIPTION - GENERAL

- A. The general requirements specified herein apply for the roofing system.
- B. The roofing system in general, consists of the following:
 - 1. Roof membrane top ply torched or hot mopped to roof deck.
- C. Roofing system component that contains asbestos material shall NOT be permitted on this Project.

2.03 SYSTEM "D" (SOPREMA) COMPONENTS

- A. **Roof Membrane Top Ply:** Polyester reinforcement and thermofusible elastomeric asphalt, with a fire retardant added. Underside protected by a thermofusible film. Top side self-protected with colored granules. Comply with ASTM D 5147 and ASTM D 4073.
 - 1. Thickness: 160 mils.
 - 2. Color: "White".
 - 3. Application Technique: Torching.
 - 4. Product: "Flam 180 GR FR"

2.04 ACCESSORIES

- A. **General:** Furnish auxiliary materials recommended by roofing system manufacturer for intended use and compatible with roofing system.
 - 1. Note that pitch pans are NOT acceptable for this Project.
- B. **Asphalt Primer:** Comply with ASTM D 41.

1. System "D": "Elastocol 500."
- C. Roofing Asphalt: Comply with ASTM D 312, Type III.
- D. Water Cut-Off Mastic:
1. System "D": "Sopracolle" or "Sopramastic".
- E. Sealant Materials: Provide polyurethane joint sealants as specified herein for sealing joints in metal flashings, counterflashings, copings, and thru-wall scuppers; comply with ASTM C 920. Color as selected by Department from manufacturer's standard line.
1. Joint Backing: Closed cell polyethylene in round or square shape. Non-staining, non-absorbent and capable of at least 30 percent recovery.
 2. Products, Horizontal Joints: Provide one of the following Type I, Class sealants:
 - a. "Sonolastic SL 2"; Sonneborn Building Products, Div. of Chemrex, Inc.
 3. Products, Vertical Joints: Provide one of the following Type II, Class A sealants:
 - a. "Sonolastic NP 2"; Sonneborn Building Products, Div. of Chemrex, Inc.
- F. Conduit and Pipe Seals for Through-Roof Penetrations:
1. Single Pipe or Conduit Penetrations: Provide an EPDM boot-type flashing assembly, sized to accommodate dimension of pipe or conduit. Complete with a stainless steel drawband closure.
 - a. Product: "Pipe Boot"; Portals Plus, Inc.
 2. Multiple Pipe or Conduit Penetrations: Provide an EPDM cap mechanically sealed to a flashing base; cap configuration to suit number of penetrations. Complete with a stainless steel drawband.
 - a. Product: "Alumi-Flash System"; Portals Plus, Inc.

PART 3 – EXECUTION

3.01 EXAMINATION

- A. Examine substrates, areas, and conditions under which roofing will be applied, with Installer present, for compliance with requirements.
- B. Verify that roof openings and penetrations are in place and set and braced and that roof drains are properly clamped into position.
- C. Verify that wood blocking, curbs, and nailers are securely anchored to roof deck at roof penetrations and terminations and match thicknesses of insulation required.
- D. Do not proceed with installation until after the minimum concrete curing period recommended by roofing system manufacturer.

1. Test concrete substrate for excessive moisture by pouring 1 pint of roofing asphalt at equiviscous temperature on deck at start of each day's work and at start of each roof area or plane. Do not proceed with roofing work if test sample foams or can be easily and cleanly stripped after cooling.

E. Do not proceed with installation until unsatisfactory conditions have been corrected.
3.02 **PREPARATION**

- A. Clean substrate of dust, debris, and other substances detrimental to roofing installation according to roofing system manufacturer's written instructions. Remove sharp projections.
- B. Prevent materials from entering and clogging roof drains and conductors and from spilling or migrating onto surfaces of other construction. Remove roof drain plugs when no work is taking place or when rain is forecast.

3.03 **GENERAL INSTALLATION REQUIREMENTS**

- A. Install roofing system according to roofing system manufacturer's written instructions and applicable recommendations of NRCA/ARMA's "Quality Control Recommendations for Polymer Modified Bitumen Roofing."
- B. Start installation of roofing in presence of roofing system manufacturer's technical personnel.
- C. Coordinate timing of installation to occur at times of phased construction.
- D. Shingling Plies: Install roofing system with ply sheets shingled uniformly to achieve required number of membrane plies throughout. Shingle in direction to shed water.
- E. Cant Strips: Install and secure preformed 45-degree cant strips at junctures of modified bituminous membrane roofing system with vertical surfaces or angle changes greater than 45 degrees.
- F. Coordinate installing roofing system components so insulation and roofing plies are not exposed to precipitation or left exposed at the end of the workday or when rain is forecast.
 1. Provide cutoffs at end of each day's work to cover exposed ply sheets and insulation with a course of coated felt with joints and edges sealed.
 2. Complete terminations and base flashings and provide temporary seals to prevent water from entering completed sections of roofing system.
 3. Remove and discard temporary seals before beginning work on adjoining roofing.
- G. Asphalt Heating: Heat roofing asphalt and apply within plus or minus 25 deg F of equiviscous temperature, unless otherwise required by roofing system manufacturer. Do not raise roofing asphalt temperature above the equiviscous temperature range more than one hour before time of application. Do not exceed roofing asphalt manufacturer's recommended temperature limits during roofing asphalt heating. Do not heat roofing asphalt within 25 deg F of flash point. Discard roofing asphalt maintained at a temperature exceeding 500 deg F for more than 4 hours. Keep kettle lid closed, unless adding roofing asphalt.
 1. Substrate Joint Penetrations: Prevent roofing asphalt from penetrating substrate joints, entering building, or damaging roofing system components or adjacent building construction. If mopping is applied directly to substrate, tape substrate joints.

SPECIAL PROVISION SECTION 763 – BUS PAVILION AND/OR
SECTION 999 – ARCHITECTURAL CONSTRUCTION MAINTENANCE BUILDING
SBS MODIFIED BITUMINOUS ROOFING

7

3.04 ROOF MEMBRANE INSTALLATION

- A. General: Install roof membrane over area to receive roofing, according to manufacturer's written instructions. Extend roof membrane over and terminate beyond eaves.
 - 1. Unroll sheet and allow it to relax for the minimum time period required by manufacturer.
- B. Single Ply, Modified Bituminous Membrane: Install plies of modified bituminous membrane, consisting of a finish ply, starting at low point of roofing system.
 - 1. Finish Ply Application: Torch apply to base ply.
- C. Laps: Accurately align sheets, without stretching, and maintain uniform side and end laps. Stagger end laps. Completely bond and seal laps, leaving no voids.
 - 1. Repair tears and voids in laps and lapped seams not completely sealed.
 - 2. Apply granules, while asphalt is hot, to cover asphalt bead exuded at laps.
- D. Install modified bituminous membranes with side laps shingled with slope of roof deck where possible.

3.05 FLASHING AND STRIPPING INSTALLATION

- A. Install modified bituminous membrane base flashing over cant strips and other sloping and vertical surfaces, at roof edges, and at penetrations through roof, and secure to substrates according to roofing system manufacturer's written instructions and as follows:
 - 1. Prime substrates with asphalt primer if required by roofing system manufacturer.
 - 2. Base Ply Flashing Application: Install base ply flashing membrane and adhere to substrate in a uniform mopping of hot roofing asphalt.
 - 3. Top Ply Flashing Application: Torch apply modified bituminous membrane base flashing to substrate.
- B. Extend base flashing up the wall a minimum of 8 inches above roof membrane and 4 inches onto field of roof membrane.
- C. Mechanically fasten top of modified bituminous membrane base flashing securely at terminations and perimeter of roofing.
 - 1. Seal top termination of base flashing.
- D. Install modified bituminous stripping where metal flanges and edgings are set on membrane roofing, according to roofing system manufacturer's written instructions.

3.08 FIELD QUALITY CONTROL

- A. Final Roof Inspection: Arrange for roofing system manufacturer's technical personnel to inspect roofing installation on completion and submit report to Engineer.
 - 1. Notify Authority and Engineer 48 hours in advance of the date and time of inspection.

SPECIAL PROVISION SECTION 763 – BUS PAVILION AND/OR
SECTION 999 – ARCHITECTURAL CONSTRUCTION MAINTENANCE BUILDING
SBS MODIFIED BITUMINOUS ROOFING

8

3.09 PROTECTING AND CLEANING

- A. Protect membrane roofing from damage and wear during remainder of construction period. When remaining construction will not affect or endanger roofing, inspect roofing for deterioration and damage, describing its nature and extent in a written report, with copies to Department and Engineer.
- B. Correct deficiencies in or remove roofing that does not comply with requirements, repair substrates, reinstall roofing, and repair base flashings to a condition free of damage and deterioration at the time of Final Acceptance and according to warranty requirements.
- C. Clean overspray and spillage from adjacent construction using cleaning agents and procedures required by manufacturer of affected construction.

3.10 PAYMENT

- A. Lump sum price for Bus Pavilion and Architectural Construction Maintenance Building covers all items of work in this Special Provision including furnishing labor, materials, tools, equipment, and incidentals required to complete the work.

END OF SECTION

State Road and Tollway Authority (SRTA), State of Georgia

SPECIAL PROVISION

Section 763 – Bus Pavilion and/or Section 999 – Architectural Construction Maintenance Building

Section 079200 – Joint Sealants

PART 1 – GENERAL

1.01 SUMMARY

- A. This Section includes the furnishing and installation of joint sealants as indicated on the Drawings and as specified herein.

1.02 RELATED WORK

- A. CONCRETE UNIT MASONRY: Section 04 22 00.
- B. METAL DOORS AND FRAMES: Section 08 11 00.
- C. PAINTING: Section 09 91 00.

1.03 QUALITY ASSURANCE

- A. **Installer Qualifications:** The Installer shall have a minimum of five (5) years continuous documented experience in the application of the types of materials required, and approved or licensed by the manufacturer to install elastomeric sealants required for this Project.
- B. **Product Testing:** Obtain test results for test reports required as submittals from a qualified testing agency based on testing current sealant formulations within a 36 month period preceding commencement of the Work.
 - 1. **Testing Agency Qualifications:** An independent testing agency qualified according to ASTM C 1021 to conduct the testing indicated, as documented according to ASTM E 548.
 - 2. Test elastomeric joint sealants for compliance with requirements specified by reference to ASTM C 920, and where applicable, to other standard test methods.
 - 3. Test other joint sealants for compliance with requirements indicated by referencing standard specification and test methods.
- C. **Performance Requirements:** Provide elastomeric joint sealants that establish and maintain watertight and airtight continuous joint seals without staining or deteriorating joint substrates.

1.04 SUBMITTALS

- A. **Product Data:** Submit complete manufacturer's technical data for each manufactured item. Include the following:
 - 1. Certification that each product to be furnished is recommended for the application shown.
 - 2. Complete instructions for handling, storage, mixing, priming, installation, curing, and protection of each type of sealant.
- B. **Samples:** Submit the following samples:
 - 1. One tube, in original sealed container, of each sealant specified.
 - 2. 12 inch length of each joint filler specified.
- C. **Qualification Data:** For Installer and testing agency.
- D. **Compatibility and Adhesion Test Reports:** From sealant manufacturer, indicating the following:
 - 1. Materials forming joint substrates and joint sealant backings have been tested for compatibility and adhesion with joint sealants.
 - 2. Interpretation of test results and written recommendations for primers and substrate preparation needed for adhesion.

1.05 PRODUCT DELIVERY AND STORAGE

- A. Deliver all products to the Project site undamaged, and in the manufacturer's original packing. Store products within the manufacturer's published temperature tolerances.

1.06 ENVIRONMENTAL CONDITIONS

- A. Do not install joint sealant materials when the ambient and substrate temperatures are below 40 degrees F, unless the manufacturer specifically recommends application of materials at lower temperatures. If Project progress or any other condition requires installations when ambient and substrate temperatures are below 40 degrees F (or below the minimum installation temperature recommended by the manufacturer), consult the manufacturer's representative and establish the minimum provisions required to ensure satisfactory work. Record in writing to the manufacturer, with a copy to the Engineer, the conditions under which such installation must proceed, and the provisions made to ensure satisfactory work.
- B. Do not proceed with installation of bulk compounds during inclement weather unless the full compliance with all requirements and manufacturer's published instructions. Do not proceed with the installation of elastomeric sealants under extreme temperature conditions which would cause joint openings to be at either maximum or minimum width, or when such extreme temperatures or heavy wind loads are forecast during the period required for initial or nominal cure of elastomeric sealants. Whenever possible, schedule the installation and cure of elastomeric sealants during periods of mean temperatures (nominal joint width shown) so that subsequent stresses upon the cured sealants will be minimized.

1.07 WARRANTY

- A. **Special Project Warranty:** Provide a manufacturer's warranty against defects materials and workmanship for joint sealants which fail to perform as airtight or watertight joints; or fail in joint adhesion, cohesion, abrasion resistance, weather resistance, extrusion resistance, migration resistance, stain resistance, or general durability; or appear to deteriorate in any other manner not clearly specified in joint sealant manufacturer's published data as an inherent quality of the material for the exposure indicated.
1. **Warranty Period:** Ten years from the date of Final Acceptance.

PART 2 – PRODUCTS

2.01 GENERAL

- A. Hardnesses indicated and specified are intended to indicate the general range necessary for overall performance. The manufacturer's technical representative shall determine the actual hardness recommended for the conditions of installation and use. Except as otherwise indicated or recommended, compounds shall be provided within the range of hardness (Shore A, Fully cured, at 75 degrees F) of 25 to 40.
- B. Prior to installation of each specified sealant, confirm its compatibility with the joint surfaces, joint fillers, and other materials in the joint system. Only materials that are known to be fully compatible with the actual installation conditions, as shown by manufacturer's published data or certification, shall be provided.

2.02 SEALANTS

- A. **Exterior Sealants:** Sealants for exterior locations and all interior and exterior expansion joints shall be cold-applied elastomeric joint sealant, two-part polyurethane sealant complying with ASTM C 920.
1. **Products, Horizontal Joints:** Provide one of the following Type M (multicomponent), Class 25, use T (traffic) sealants:
 - a. "Urexpan NR-200"; Pecora Corporation.
 - b. "Vulkem 245"; Tremco.
 - c. "Sonolastic SL 2"; Sonneborn, Div. of ChemRex, Inc.
 2. **Products, Vertical Joints:** Provide one of the following Type M (multicomponent), Class 25, use NT (nontraffic) sealants:
 - a. "Dynatrol II"; Pecora Corporation.
 - b. "Vulkem 227"; Tremco.
 - c. "Sonolastic NP 2"; Sonneborn, Div. of ChemRex, Inc.
- B. **Interior Sealants:** Sealants for interior locations shall be acrylic latex sealant compound, non-staining, non-bleeding, paintable, complying with ASTM C 834.

1. **Products:** Provide one of the following sealants:
 - a. "AC-20+"; Pecora Corporation.
 - b. "Sondlac"; Sonneborn, Div. of ChemRex, Inc.
 - c. "Tremflex 834"; Tremco.

2.03 MISCELLANEOUS MATERIALS

- A. **Cleaners for Nonporous Surfaces:** Chemical cleaners acceptable to manufacturers of sealants and sealant backing materials, free of oily residues or other substances capable of staining or harming joint substrates and adjacent nonporous surfaces in any way, and formulated to promote optimum adhesion of sealants to joint substrates.
- B. **Bond-Breaker Tape:** Polyethylene tape or other plastic tape recommended by the sealant manufacturer for preventing sealant from adhering to rigid, inflexible joint filler materials or joint surfaces at back of joint where such adhesion would result in sealant failure. Provide self-adhesive tape where applicable.
- C. **Backer Rods:** Provide closed-cell, expanded polyethylene backer rods. The size and shape of the rod shall be that which will control the joint, form optimum shape of sealant bead on the back side, and provide a highly compressible backer to minimize the possibility of sealant extrusion when the joint is compressed.
 1. **Basis of Design:** "Ethafoam"; Dow Chemical Company.

2.04 COLORS

- A. For concealed joints, provide manufacturer's standard color from the product that has the best overall performance qualities for the application shown. For exposed joints, the Engineer will select colors from the manufacturer's standard or premium line of colors from the product that provides the match to the materials.

PART 3 – EXECUTION

3.01 INSPECTION

- A. Examine joints indicated to receive joint sealants, with Installer present, for compliance with requirements for joint configuration, installation tolerances, and other conditions affecting joint sealant performance.
- B. Proceed with installation only after unsatisfactory conditions have been corrected.

3.02 PREPARATION

- A. **Surface Cleaning of Joints:** Clean out joints immediately before installing joint sealants to comply with joint sealant manufacturer's written instructions and the following requirements:
 1. Remove all foreign material from joint substrates that could interfere with adhesion of joint sealant, including dust, paints (except for permanent, protective coatings tested and approved for sealant adhesion and compatibility by sealant manufacturer), old joint sealants, oil, grease, waterproofing, water repellents, water, surface dirt, and frost.

SPECIAL PROVISION SECTION 763 – BUS PAVILION AND/OR
SECTION 999 – ARCHITECTURAL CONSTRUCTION MAINTENANCE BUILDING
JOINT SEALANTS

4

2. Clean concrete, masonry, and similar porous joint substrate surfaces by brushing, grinding, blast cleaning, mechanical abrading, or a combination of these methods to produce a clean, sound substrate capable of developing optimum bond with joint sealants. Remove loose particles remaining after cleaning operations above by vacuuming or blowing out joints with oil-free compressed air.
 3. Remove laitance and form-release agents from concrete.
 4. Clean metal and similar nonporous surfaces with chemical cleaners or other means that do not stain, harm substrates, or leave residues capable of interfering with adhesion of joint sealants.
- B. **Joint Priming:** Prime joint substrates, where recommended in writing by joint sealant manufacturer, based on prior experience. Apply primer to comply with joint sealant manufacturer's written instructions. Confine primers to areas of joint sealant bond; do not allow spillage or migration onto adjoining surfaces.
- C. **Masking Tape:** Use masking tape where required to prevent contact of sealant with adjoining surfaces that otherwise would be permanently stained or damaged by such contact or by cleaning methods required to remove sealant smears. Remove tape immediately after tooling without disturbing joint seal.

3.03 JOINT SEALANT INSTALLATION

- A. **General:** Comply with joint sealant manufacturer's published instructions, unless more stringent requirements are shown or specified, or the manufacturer's technical representative recommends otherwise.
- B. **Sealant Installation Standard:** Comply with recommendations in ASTM C 1193 for use of joint sealants as applicable to materials, applications, and conditions indicated.
- C. **Prime or seal joint surfaces** as indicated or recommended by the sealant manufacturer. Do not spill or allow primers or sealers to migrate onto adjoining surfaces.
- D. **Install sealant backer rods** for all elastomeric sealants, unless indicated to be omitted or recommended to be omitted by sealant manufacturer for the application shown.
- E. **Install bond breaker tape** where required by manufacturer's recommendations to ensure that elastomeric sealants will perform properly, or as indicated on the Drawings.
- F. **Employ only proven installation techniques** that will ensure sealants are deposited in uniform, continuous ribbons without gaps or air pockets, with complete "wetting" of the joint bond surfaces equally on opposite sides. Unless otherwise indicated, fill sealant joints to a slightly concave surface and slightly below adjoining surfaces. Where horizontal joints occur between a horizontal surface and a vertical surface, fill joints to form a slight cove, so that the joint will not trap moisture and dirt.
1. Use tooling agents that are approved in writing by sealant manufacturer and that do not discolor sealants or adjacent surfaces.
- G. **Install sealants to depths indicated**, or if not indicated, as recommended by the sealant manufacturer, but within the following general limitations measured at the center (thin) section of the bead.

SPECIAL PROVISION SECTION 763 – BUS PAVILION AND/OR
SECTION 999 – ARCHITECTURAL CONSTRUCTION MAINTENANCE BUILDING
JOINT SEALANTS

5

1. For sidewalks, pavements, and similar joints sealed with elastomeric sealants and subject to traffic and other abrasion and indentation exposure, fill joints to a depth equal to 75 percent of the joint width, but neither more than 5/8 inch deep nor less than 3/8 inch deep.
 2. For normal moving joints sealed with elastomeric sealants, but not subject to traffic. Fill joints to a depth equal to 50 percent of joint width, but not more than 3/8 inch nor less than 1/4 inch.
 3. For joints sealed with non-elastomeric sealant compounds, fill joints to a depth in the range of 75 percent to 115 percent of the joint width.
- H. Do not permit joint sealant materials (primers, sealers, or sealants) to spill onto adjoining surfaces, or be allowed to migrate into the voids of adjoining surfaces including rough textures. Use masking tape or other precautionary devices to prevent staining of adjoining surfaces.
- I. Promptly remove excess sealant from surfaces adjacent to joints as the work progresses. Clean adjoining surfaces as necessary to eliminate evidence of spillage, without damage to the adjoining surfaces or finishes.
- J. Do not plug weep holes (if occurring) built into aluminum framing.

3.04 CURE AND PROTECTION

- A. Cure sealants in compliance with the manufacturer's published instructions and current recommendations to obtain high early bond strength, internal cohesive strength, and surface durability.
- B. The installer shall advise the Contractor of procedures required for the curing and protection of sealants compounds during the construction period, so that they will be without deterioration or damage (other than normal wear and weathering), at the time of Final Acceptance.

3.05 PAYMENT

- A. Lump sum price for Bus Pavilion and Architectural Construction Maintenance Building covers all items of work in this Special Provision including furnishing labor, materials, tools, equipment, and incidentals required to complete the work.

END OF SECTION

State Road and Tollway Authority (SRTA), State of Georgia

SPECIAL PROVISION

Section 763 – Bus Pavilion and/or Section 999 – Architectural Construction Maintenance Building

Section 081100 – Metal Doors and Frames

PART 1 – GENERAL

1.01 SUMMARY

- A. Furnish and install all flush steel doors and steel door frames as indicated on the Drawings and specified herein.

1.02 RELATED WORK

- A. CONCRETE UNIT MASONRY: Section 04 22 00.
- B. JOINT SEALANTS: Section 07 92 00.
- C. PAINTING: Section 09 91 00.

1.03 QUALITY ASSURANCE

- A. Manufacturer: Provide steel doors and frames manufactured by a single firm specializing in the production of this type of work.
- B. Design Criteria: Comply with the following: Thermal Design Criteria: Fabricate all exterior door assemblies as thermal insulated door and frame assemblies, tested in accordance with ASTM C 236. Provide thermal-rated assemblies with a minimum U-Factor of 0.24.

1.04 SUBMITTALS

- A. Product Data: Submit manufacturer's technical information and installation instructions for each type of door and frame. Include core description, construction details, and finishes.
- B. Shop Drawings: Submit shop drawings for the fabrication and installation of the steel doors and frames. Drawings shall include details of each frame type, elevations of door design types, conditions at openings, details of construction, location and installation requirements of finish hardware, and reinforcements and details of joints and connections, showing anchorage and accessory items.
 1. Include a schedule of doors and frames using the same opening numbers referenced on the Drawings and the same schedule format.
 2. Submit shop drawings as a package with the submittals for other doors and finish hardware to facilitate a coordinated review.

SPECIAL PROVISION SECTION 763 – BUS PAVILION AND/OR
SECTION 999 – ARCHITECTURAL CONSTRUCTION MAINTENANCE BUILDING
METAL DOORS AND FRAMES

1

3. Shop drawings shall indicate accurate dimensions of work shown. Frame returns shall allow for conditions (i.e., whether 3/4 inch plywood board; or exposed masonry as scheduled). Except where otherwise shown, provide a 1/4 inch sealant space shall be provided for each jamb and head abutting wall materials.
4. List and locate all items of finish hardware furnished and prepared for by the manufacturer of steel doors and frames, from templates provided by the hardware supplier.
5. Provide NOA numbers or Certified Test Lab reports showing tested assemblies of all exterior doors, frames and hardware that meet the IBC requirements. Each opening is to be tested as an assembly with doors, frames and finish hardware. Submittals shall include door and frame elevations, internal reinforcement, finish hardware and installation instructions.

1.05 DELIVERY, STORAGE, AND HANDLING

- A. Protect doors and frames during transit, storage, and handling to prevent damage, soiling, and deterioration.
- B. Package each door at the factory in a separate heavy paper carton. Mark each carton for location to correspond with the shop drawings.
- C. Ship welded frames in bundles securely strapped or in packages.
- D. Store doors and frames at the building site under cover. Store frames in an upright position. Place the units on minimum 4 inch high wood sills or on floors in a manner to prevent rust or damage. Avoid the use of nonvented plastic or canvas shelters that may create a humidity chamber. If the wrapper on the door becomes wet, remove the carton immediately. Provide a 1/4 inch air space between the doors to promote air circulation.

1.06 PROJECT CONDITIONS

- A. Measurements: Obtain and verify all measurements at the buildings as required to properly fabricate and install all special door and frame requirements if and when they occur. Verify all conditions which may affect door installation.

PART 2 – PRODUCTS

2.01 MANUFACTURERS

- A. Products: Provide one of the following:
 1. "Lock Seam Design"; American Steel Products.
 2. "Series H"; Pioneer Industries, Inc.
 3. "Series L"; Steelcraft Div. of Ingersoll Rand.

2.02 STEEL FRAMES

- A. Frames shall be double rabbeted design, depth and profile as indicated on Drawings, complete with a minimum 5/8 inch stop. Fabricate frames from 14 gage (0.067 inch) commercial quality galvanized steel sheets complying with ASTM A 653 for an A40 galvanized coating; stretcher-

SPECIAL PROVISION SECTION 763 – BUS PAVILION AND/OR
SECTION 999 – ARCHITECTURAL CONSTRUCTION MAINTENANCE BUILDING
METAL DOORS AND FRAMES

2

leveled standard of flatness. Frames shall be designed with integral stop and trim.

1. Knockdown frames are NOT acceptable.

- B. Frame corners shall be mitered and continuously arc welded (both inside of mitered corners and butt edges) with all exposed welds ground and sanded smooth. Mitered corners shall be reinforced with 18-gauge (0.042 inch) channel-shaped reinforcements.
- C. Head members shall be 2 inches high, unless otherwise indicated.
- D. Strike jambs shall be provided with three (3) holes for rubber bumpers (silencers).

2.03 STEEL DOORS

- A. Hollow metal doors shall be 1-3/4 inches thick heavy-duty, full flush hollow steel, lock seam construction. Fabricate doors from 14 gage (0.042 inch) commercial quality galvanized steel sheets complying with ASTM A 653 for an A40 galvanized coating; stretcher-leveled standard of flatness.
- B. Door face sheets formed from one sheet of metal with no seams permitted on door face. Seams permitted on vertical edge of door only. Provide welds on 2 inch centers around door perimeter; use projection welding method. Provide flush and closed tops with no holes. Top and bottom of door closed with a minimum 16 gage (0.053 inch) flush or inverted closure channel.
- C. Core: Provide a 1 inch thick cell honeycomb laminated to the inside of both face panels with a waterproof adhesive. Provide 99 lb. test kraft paper core material with a minimum crushing strength of 4000 psf and minimum lamination shear value of 1100 psf.
- D. The clearances for doors shall be 3/32- to 1/8-inch at jambs and heads. The lock edges of stiles shall be beveled 1/8 inch in 2 inches for steel doors.
- E. The top and bottom edges of all exterior steel doors shall be closed flush with a continuous steel channel, extending the full width of the door and welded to both faces to provide a weather-tight seal. This seal shall be provided as part of the door construction. Openings shall be provided in the bottom closure to permit the escape of entrapped moisture.

2.04 FINISH

A. Shop Applied Finish:

- 1. Apply a primed finish to all galvanized and non-galvanized metal surfaces furnished under this Section. Clean and chemically treat metal surfaces to assure maximum paint adherence; follow with a dip or spray coat of rust-inhibitive metallic oxide, zinc chromate, or synthetic resin primer on all exposed surfaces.
- 2. Finished surfaces shall be smooth and free from irregularities and rough spots. Paint shall be baked or oven dried. The time and temperature for drying shall be in accordance with manufacturer's recommendations for developing maximum hardness and resistance to abrasion.

B. Paint Finish: Finish painting of steel doors and frames is specified under Section 09 91 00 - PAINTING.

2.05 HARDWARE PROVISIONS AND REINFORCING

SPECIAL PROVISION SECTION 763 – BUS PAVILION AND/OR
SECTION 999 – ARCHITECTURAL CONSTRUCTION MAINTENANCE BUILDING
METAL DOORS AND FRAMES

3

A. Hardware Provisions for Pressed Steel Frames:

1. Unless a different strike is noted on Hardware Schedule, frames shall have steel hinge plate reinforcement projection welded with provisions for 4-1/2 inch x 4-1/2 inch full mortise type hinges and steel strike tap plate reinforcement projection welded with provisions for Universal ANSI A115.1 or A115.2 strike.
2. Frames shall be provided for 1-1/2 pair of hinges, unless noted otherwise. Mortar guards shall be formed from 26-gauge galvanized steel and shall be welded in place.
3. Closer reinforcement shall be sleeve type installed in frame header for all doors which are indicated to receive door closers.
4. Provide metal reinforcements for all other hardware items indicated.
5. Minimum gauges of hardware reinforcing plates shall be as follows:
 - a. Hinge Reinforcements: 8 gauge, 1-1/4 x 10-inch minimum size.
 - b. Lock Reinforcements: 12 gauge.
 - c. Closer Reinforcements: 12 gauge.
 - d. Surface-Mounted Hardware: 12 gauge.

B. Hardware Provisions for Steel Doors:

1. Mortise, reinforce, drill and tap doors at the factory to receive all mortised type hardware. Drilling and tapping for surface applied hardware shall be performed in field. Provide concealed metal reinforcement for surface applied hardware indicated in the Hardware Schedule.
2. Doors shall have steel integral hinge reinforcement with provisions for 4-1/2 inch x 4-1/2 inch full mortise template type hinges for 1-1/2 pair of hinges per door, unless noted otherwise.
3. Doors shall have steel integral lock reinforcement with provisions for locksets as indicated.
4. Doors shall have steel closer reinforcement concealed in the door for all doors that are indicated to receive closers.
5. Minimum gauges for hardware reinforcing plates shall be as follows:
 - a. Hinge Reinforcements: 8 gauge.
 - b. Lock Reinforcements: 12 gauge.
 - c. Closer Reinforcements: 12 gauge.
 - d. Surface Mounted Hardware: 14 gauge.

- C. Location of Hardware:** The location of hardware in connection with hinged and other swing type hollow metal doors and frames shall be as follows, unless indicated or specified otherwise:

**SPECIAL PROVISION SECTION 763 – BUS PAVILION AND/OR
SECTION 999 – ARCHITECTURAL CONSTRUCTION MAINTENANCE BUILDING
METAL DOORS AND FRAMES**

4

1. **Top Hinge:** To manufacturer's standard, but not greater than 5 inches from head rabbet to top of hinge.
2. **Bottom Hinge:** To manufacturer's standard but not greater than 10 inches from finish floor to bottom of hinge.
3. **Intermediate Hinge:** Equally spaced between top and bottom hinge.
4. **Locks:** 38-40 inches from finish floor to center of strike.
5. **Refer to Section 08 71 00 - DOOR HARDWARE** for additional locations.
6. **Refer to drawings** for additional applied door protection.

D. Anchors:

1. **Furnish eight (8) per frame,** deformed type adjustable anchors as condition applies.

2.06 WORKMANSHIP

- A. **All work shall be shop fabricated** to required profiles by forming and welding with corners, angles and edges straight and sharp.
- B. **Fit and fabricate accurately** with corners, joints, seams and surfaces free from warp, buckles or other defects.

PART 3 – EXECUTION

3.01 INSPECTION

- A. **Examine the areas and conditions** under which steel doors and frames are to be installed. Do not proceed with steel door and frame installation until unsatisfactory conditions have been corrected.

3.02 DOOR AND FRAME INSTALLATION

- A. **General:** Install standard steel doors, frames and accessories in accordance with approved shop drawings, manufacturer's data and as herein specified.
- B. **Steel Frames:** Comply with provisions of SDI-105 "Recommended Erection Instructions for Steel Frames," unless otherwise indicated.
 1. **Place frames** prior to construction of enclosing walls. Set frames accurately in position, plumbed, aligned, and braced securely until permanent anchors are set. After wall construction is completed, remove temporary braces and spreaders leaving surfaces smooth and undamaged.
 2. **In masonry construction,** wall anchors shall be located at the hinge and strike levels, and frame jambs and heads shall be grouted solid.
- C. **Steel Doors:** Fit steel doors accurately in frames, within clearances specified in SDI-100 "Recommended Specifications for Standard Steel Doors and Frames."

3.03 ADJUST AND CLEAN

- A. **Prime Coat Touch-Up:** Immediately after installation, sand smooth all rusted or damaged areas of prime coat and apply touch-up of compatible air-drying primer.
- B. **Final Adjustments:** Check and readjust operating finish hardware items, leaving steel doors and frames undamaged and in complete and proper operating condition.
- C. **Cleaning:** Immediately prior to final inspection and before Final Acceptance, remove all protective materials and clean all exposed members. Thoroughly clean all glass, including removal of manufacturer's labels or any other material or substance on the glass, in the event this has not been performed at a prior time. Cleaning shall be performed by the use of cleaning materials and methods which will not damage the glass or surroundings in any way.
 - 1. Do not use abrasives or harmful cleaning agents.

3.04 PAYMENT

- A. Lump sum price for Bus Pavilion and Architectural Construction Maintenance Building covers all items of work in this Special Provision including furnishing labor, materials, tools, equipment, and incidentals required to complete the work.

END OF SECTION

State Road and Tollway Authority (SRTA), State of Georgia

SPECIAL PROVISION

Section 763 – Bus Pavilion and/or Section 999 – Architectural Construction Maintenance Building

Section 088100 – Glass and Glazing

PART 1 - GENERAL

1.1 WORK INCLUDED

- A. This Section includes glazing for the following products, including those specified in other Sections where glazing requirements are specified.
- B. Glazing locations shall be as indicated on the Drawings.
- C. Related Sections: The following sections contain requirements that relate to this Section.
 - 1. Structural Steel Framing: per Structural Drawings

1.2 DEFINITIONS

- A. Manufacturer is used in this Section to refer to a firm that produces primary glass or fabricated glass as defined in the referenced glazing standard.
- B. Deterioration of Laminated Glass: Defects developed from normal use that are attributed to the manufacturing process and not to glass breakage and practices for maintaining and cleaning laminated glass contrary to manufacturer's directions. Defects include edge separation, delamination materially obstructing vision through glass, and blemishes exceeding those allowed by referenced laminated glass standard.

1.3 SYSTEM PERFORMANCE REQUIREMENTS

- A. General: Provide glazing systems that are produced, fabricated, and installed to withstand normal thermal movement, wind loading, and impact loading (where applicable), without failure including loss or glass breakage attributable to the following: defective manufacture, fabrication, and installation; failure of sealants or gaskets to remain watertight and airtight; deterioration of glazing materials; and other defects in construction.
 - 1. Provide glass units for exterior openings that have Miami-Dade Products Control Approval for hurricane wind resistance and air-borne missile impact from hurricane force winds.
- B. Glass Design: Glass thicknesses indicated on Drawings are for detailing only. Confirm glass thicknesses by analyzing Project loads and in-service conditions. Provide glass lites for the various size openings in the thicknesses and strengths (annealed or heat-treated) to meet or exceed the following criteria:

SPECIAL PROVISION SECTION 763 – BUS PAVILION AND/OR
SECTION 999 – ARCHITECTURAL CONSTRUCTION MAINTENANCE BUILDING
GLASS AND GLAZING

1

1. Minimum glass thickness, nominally, of lites in exterior walls is 9/16-inch unless otherwise indicated.
 2. Minimum glass thicknesses of lites, whether composed of annealed or heat-treated glass, are selected so the worst-case probability of failure does not exceed 8 lites per 1000 for lites set vertically or not over 15 degrees off vertical and under wind action. Determine minimum thickness of monolithic annealed glass according to ASTM E 1300. For other than monolithic annealed glass, determine thickness per glass manufacturer's standard method of analysis including applying adjustment factors to ASTM E 1300 based on type of glass.
- C. Normal thermal movement results from the following maximum change (range) in ambient and surface temperatures acting on glass-framing members and glazing components. Base engineering calculation on materials' actual surface temperatures due to both solar heat gain and nighttime sky heat loss. Temperature Change (Range): 120 degrees F ambient; 180 degrees F, material surfaces.

1.4 SUBMITTALS

- A. Product data for each glass product and glazing material indicated.
- B. Samples for verification purposes of 12-inch-square samples of each type of glass indicated except for clear monolithic glass products, and 12-inch-long samples of each color required (except black) for each type of sealant or gasket exposed to view. Install sealant or gasket sample between two strips of material representative in color of the adjoining framing system.
- C. Product certificates signed by glazing materials manufacturers certifying that their products comply with specified requirements. Separate certifications are not required for glazing materials bearing manufacturer's permanent labels designating type and thickness of glass, provided labels represent a quality control program of a recognized certification agency or independent testing agency acceptable to authorities having jurisdiction.
- D. Compatibility and adhesion test reports from sealant manufacturer indicating that glazing materials were tested for compatibility and adhesion with glazing sealants. Include sealant manufacturer's interpretation of test results relative to sealant performance and recommendations for primers and substrate preparation needed for adhesion.
- E. Product test reports for each type of glazing sealant and gasket indicated, evidencing compliance with requirements specified.
- F. Maintenance data for glass and other glazing materials to be included in Operating and Maintenance Manual specified in Division 1.

1.5 QUALITY ASSURANCE

- A. Glazing Publications: Comply with published recommendations of glass product manufacturers and organizations below, except where more stringent requirements are indicated. Refer to these publications for glazing terms not otherwise defined in this Section or in referenced standards.
 1. FGMA Publications: "FGMA Glazing Manual."
 2. LSGA Publications: "LSGA Design Guide."

3. **SIGMA Publications:** TM-3000 "Vertical Glazing Guidelines".

- B. **Safety Glass:** Products complying with ANSI Z97.1 and testing requirements of 16 CFR Part 1201 for Category II materials.
- B. **Glazier Qualifications:** Engage an experienced glazier who has completed glazing similar in material, design, and extent to that indicated for Project with a record of successful in-service performance.
- C. **Single-Source Responsibility for Glass:** Obtain glass from one source for each product indicated below:
 - 1. Laminated glass of each (ASTM C 1172) kind indicated.
- E. **Single-Source Responsibility for Glazing Accessories:** Obtain glazing accessories from one source for each product and installation method indicated.
- F. **Preconstruction Compatibility and Adhesion Testing:** Submit to sealant manufacturers, samples of each glass, gasket, glazing accessory, and glass-framing member that will contact or affect glazing sealants for compatibility and adhesion testing as indicated below:
 - 1. Use test methods standard with sealant manufacturer to determine if priming and other specific preparation techniques are required for rapid, optimum glazing sealants adhesion to glass and glazing channel substrates. Perform tests under normal environmental conditions during installation.
 - 2. Submit not less than nine pieces of each type and finish of glass-framing members and each type, class, kind, condition, and form of glass (monolithic, laminated, insulating units) for adhesion testing, as well as one sample of each glazing accessory (gaskets, setting blocks and spacers) for compatibility testing.
 - 3. Schedule sufficient time to test and analyze results to prevent delay in the Work.
 - 4. Investigate materials failing compatibility or adhesion tests. Obtain sealant manufacturer's written recommendations for corrective measures, including using special primers.
 - 5. Testing is not required when glazing sealant manufacturer can submit required preparation data that is acceptable to Architect/Engineer and is based on previous testing of current sealant products for adhesion to and compatibility with submitted glazing materials.
- G. **Pre-Installation Conference:** Conduct conference at Project site to comply with requirements of the Contract document.

1.6 DELIVERY, STORAGE, AND HANDLING

- A. Protect glazing materials to comply with manufacturer's directions and as needed to prevent damage to glass and glazing materials from condensation, temperature changes, direct exposure to sun, or other causes.

1.7 PROJECT CONDITIONS

**SPECIAL PROVISION SECTION 763 – BUS PAVILION AND/OR
SECTION 999 – ARCHITECTURAL CONSTRUCTION MAINTENANCE BUILDING
GLASS AND GLAZING**

3

- A. **Environmental Conditions:** Do not proceed with glazing when ambient and substrate temperature conditions are outside the limits permitted by glazing materials manufacturer or when glazing channel substrates are wet from rain, frost, condensation, or other causes.

PART 2 - PRODUCTS

2.1 LAMINATED GLASS PRODUCTS

- A. **Laminated Glass Products:** Comply with ASTM C 1172 for kinds of laminated glass indicated and other requirements specified. Refer to primary and heat-treated glass requirements relating to properties of glass products comprising laminated glass products.
- B. **Interlayer:** Polyvinyl butyral sheet interlayer material, clear, and of thickness and composition to comply with testing and product approvals, but in no case less than 0.090 inch. Manufacturer: "Saflex Keepsafe" by Solutia or equivalent.
- C. **Laminating Process:** Fabricate laminated glass to produce glass free of foreign substances and air or glass pockets as follows: Laminate lites in autoclave with heat plus pressure.

2.2 ELASTOMERIC GLAZING SEALANTS

- A. **General:** Provide products of type indicated, complying with the following requirements:
 1. **Compatibility:** Select glazing sealants and tapes of proven compatibility with other materials they will contact, including glass products, seals of insulating glass units, and glazing channel substrates, under conditions of installation and service, as demonstrated by testing and field experience.
 2. **Suitability:** Comply with sealant and glass manufacturer's recommendations for selecting glazing sealants and tapes that are suitable for applications indicated and conditions existing at time of installation.
 3. **Colors:** Provide selections made by Architect/Engineer from manufacturer's full range of standard colors for products of type indicated.
- B. **Elastomeric Glazing Sealant Standard:** Provide manufacturer's standard chemically curing, elastomeric sealants of base polymer indicated that comply with ASTM C 920 requirements indicated on each Elastomeric Glazing Sealant Product Data Sheet at the end of this Section, including those referencing ASTM classifications for Type, Grade, Class and Uses.
 1. **Additional Movement Capability:** Provide products, when tested for adhesion and cohesion under maximum cyclic movement per ASTM C 719, with the capability to withstand the specified percentage change in the joint width existing at time of installation and remain in compliance with other requirements of ASTM C 920 for uses indicated.

2.3 GLAZING GASKETS

- A. **Soft Compression Gaskets:** Extruded or molded closed-cell, integral-skinned gaskets of material indicated below, complying with ASTM C 509, Type II, black, and of profile and hardness required to maintain watertight seal:
 1. EPDM
 2. Silicone
 3. Thermoplastic polyolefin rubber

4. Any material indicated above
- B. Available Manufacturers: Subject to compliance with requirements, manufacturers offering products that may be incorporated in the work include, but are not limited to, the following companies.
 1. Advanced Elastomer Systems, L.P.
 2. Schnee-Morehead, Inc.
 3. Tremco, Inc.

2.7 MISCELLANEOUS GLAZING MATERIALS

- A. General: Provide products of material, size, and shape complying with referenced glazing standard, requirements of manufacturers of glass and other glazing materials involved for glazing application indicated, and with a proven record of compatibility with surfaces contacted in installation.
- B. Cleaners, Primers and Sealers: Type recommended by sealant or gasket manufacturer.
- C. Setting Blocks: Elastomeric material with a Shore A durometer hardness of 85 +/- 5.
- D. Spacers: Elastomeric blocks or continuous extrusions with a Shore A durometer hardness required by glass manufacturer to maintain glass lites in place for installation indicated.
- E. Edge Blocks: Elastomeric material of hardness needed to limit glass lateral movement (side-walking).

2.8 FABRICATION OF GLASS AND OTHER GLAZING PRODUCTS

- A. Fabricate glass and other glazing products in sizes required to glaze openings indicated for Project, with edge and face clearances, edge and surface conditions, and bite complying with recommendations of product manufacturer and referenced glazing standard as required to comply with system performance requirements.

PART 3 - EXECUTION

3.1 EXAMINATION

- A. Examine glass framing, with glazier present, for compliance with the following:
 1. Manufacturing and installation tolerances, including those for size, squareness, offsets at corners.
 2. Presence and functioning of weep system.
 3. Minimum required face or edge clearances.
 4. Effective sealing between joints of glass-framing members.
- B. Do not proceed with glazing until unsatisfactory conditions have been corrected.

3.2 PREPARATION

SPECIAL PROVISION SECTION 763 – BUS PAVILION AND/OR
SECTION 999 – ARCHITECTURAL CONSTRUCTION MAINTENANCE BUILDING
GLASS AND GLAZING

5

- A. Clean glazing channels and other framing members receiving glass immediately before glazing. Remove coatings that are not firmly bonded to substrates.

3.3 GLAZING, GENERAL

- A. Comply with combined recommendations of manufacturers of glass, sealants, gaskets, and other glazing materials, except where more stringent requirements are indicated, including those in referenced glazing publications.
- B. Glazing channel dimensions as indicated on Drawings provide necessary bite on glass, minimum edge and face clearances, and adequate sealant thicknesses, with reasonable tolerances. Adjust as required by Project conditions during installation.
- B. Protect glass from edge damage during handling and installation as follows:
 - 1. Use a rolling block in rotating glass units to prevent damage to glass corners. Do not impact glass with metal framing. Use suction cups to shift glass units within openings; do not raise or drift glass with a pry bar. Rotate glass lites with flares or bevels on bottom horizontal edges so edges are located at top of opening, unless otherwise indicated by manufacturer's label.
 - 2. Remove damaged glass from Project site and legally disposed of off site. Damaged glass is glass with edge damage or other imperfections that, when installed, weaken glass and impair performance and appearance.
- D. Apply primers to joint surfaces where required for adhesion of sealants, as determined by pre-construction sealant-substrate testing.
- E. Install elastomeric setting blocks in sill rabbets, sized and located to comply with referenced glazing standard, unless otherwise required by glass manufacturer. Set blocks in thin course of compatible sealant suitable for heel bead.
- F. Do not exceed edge pressures stipulated by glass manufacturers for installing glass lites.
- G. Provide spacers for glass sizes larger than 50 united inches (length plus height) as follows:
 - 1. Locate spacers inside, outside, and directly opposite each other. Install correct size and spacing to preserve required face clearances, except where gaskets and glazing tapes are used that have demonstrated ability to maintain required face clearances and comply with system performance requirements.
 - 2. Provide 1/8-inch minimum bite of spacers on glass and use thickness equal to sealant width. With glazing tape, use thickness slightly less than final compressed thickness of tape.
- H. Provide edge blocking to comply with requirements of referenced glazing publications, unless otherwise required by glass manufacturer.
- I. Set glass lites in each series with uniform pattern, draw, bow, and similar characteristics.

3.4 GASKET GLAZING (DRY)

- A. Fabricate compression gaskets in lengths recommended by gasket manufacturer to fit openings exactly, with stretch allowance during installation.

- B. Secure compression gaskets in place with joints located at corners to compress gaskets producing a weather-tight seal without developing bending stresses in glass. Seal gasket joints with sealant recommended by gasket manufacturer.
- C. Install gaskets so they protrude past face of glazing stops.

3.5 SEALANT GLAZING (WET)

- A. Install continuous spacers between glass lites and glazing stops to maintain glass face clearances and to prevent sealant from extruding into glass channel weep systems until sealants cure. Secure spacers in place and in position to control depth of installed sealant relative to edge clearance for optimum sealant performance.
- B. Force sealants into glazing channels to eliminate voids and to ensure complete wetting or bond of sealant to glass and channel surfaces.
- C. Tool exposed surfaces of sealants to provide a substantial wash away from glass. Install pressurized gaskets to protrude slightly out of channel to eliminate dirt and moisture pockets.

3.6 PROTECTION AND CLEANING

- A. Protect exterior glass from breakage immediately after installation by attaching crossed streamers to framing held away from glass. Do not apply markers to glass surface. Remove nonpermanent labels, and clean surfaces.
- B. Protect glass from contact with contaminating substances resulting from construction operations including weld splatter. If, despite such protection, contaminating substances do come into contact with glass, remove them immediately as recommended by glass manufacturer.
- C. Examine glass surfaces adjacent to or below exterior concrete and other masonry surfaces at frequent intervals during construction, but not less than once a month, for build-up of dirt, scum, alkali deposits, or stains, and remove as recommended by glass manufacturer.
- D. Remove and replace glass that is broken, chipped, cracked, abraded, or damaged in any way, including natural causes, accidents and vandalism, during construction period.
- D. Wash glass on both faces in each area of Project not more than 4 days prior to date scheduled for inspections that establish date of Substantial Completion. Wash glass as recommended by glass manufacturer.

3.7 PAYMENT

- A. Lump sum price for Bus Pavilion and Architectural Construction Maintenance Building covers all items of work in this Special Provision including furnishing labor, materials, tools, equipment, and incidentals required to complete the work.

END OF SECTION

SPECIAL PROVISION SECTION 763 – BUS PAVILION AND/OR
SECTION 999 – ARCHITECTURAL CONSTRUCTION MAINTENANCE BUILDING
GLASS AND GLAZING

7

State Road and Tollway Authority (SRTA), State of Georgia

SPECIAL PROVISION

Section 763 – Bus Pavilion and/or Section 999 – Architectural Construction Maintenance Building

Section 096513 – Resilient Base

PART 1 – GENERAL

1.01 WORK INCLUDED

- A. Furnish and install resilient base complete as indicated on the Drawings and specified herein.

1.02 RELATED WORK

- A. PAINTING: Section 09 91 00.

1.03 QUALITY ASSURANCE

- A. Installer's Qualifications:
 1. Installation shall be performed only by a qualified installer with at least five (5) years documented experience in installations of a similar nature.

1.04 SUBMITTALS

- A. Product Data:
 1. Submit manufacturer's technical data for resilient base.
- B. Samples:
 1. Submit three (3) each of the following samples of type and color of resilient base required.
 - a. Samples of resilient base to match existing height and thickness.
- C. Maintenance Instructions:
 1. Submit manufacturer's recommended maintenance practices for resilient base.
- D. Installer Qualifications:
 1. Submit documented evidence of installer's qualifications.

1.05 PRODUCT DELIVERY, STORAGE AND HANDLING

SPECIAL PROVISION SECTION 763 – BUS PAVILION AND/OR
SECTION 999 – ARCHITECTURAL CONSTRUCTION MAINTENANCE BUILDING
RESILIENT BASE

1

- A. Deliver materials to site in manufacturer's original unopened containers with manufacturer's brand name and color clearly marked thereon, and store in conformity with manufacturer's recommendations.

1.06 PROJECT CONDITIONS

- A. Maintain minimum temperature of 65 degrees F in spaces to receive resilient base for at least 48 hours prior to installation, during installation, and for not less than 48 hours after installation. Stored resilient base materials in spaces where they will be installed for at least 48 hours before beginning installation.
- B. Install resilient base after other finishing operations, including painting, have been completed.

PART 2 – PRODUCTS

2.01 MATERIALS

- A. Resilient Base:
 1. 4 inch high vinyl base, 1/8 inch gage, ASTM F 1861, Type TV, with matching end stops and preformed or molded corner units.
 2. Products: Provide one of the following products; color as selected by Engineer:
 - a. Johnsonite, Inc.
 - b. Roppe Corp.
 - c. VPI Floor Products Division.
 3. Use cove base profile.
 4. Color to match existing base.
- B. Adhesives (Cements):
 1. Waterproof stabilized type as recommended by base manufacturer to suit material and substrate conditions.
- C. Patching Compound:
 1. Latex type as recommended by base manufacturer.

PART 3 – EXECUTION

3.01 INSPECTION

- A. Inspect wall surfaces to determine that they are satisfactory for resilient base installation. Wall surface shall be smooth and free from cracks, holes, ridges or coatings preventing adhesive bond, and other defects impairing performance or appearance.
- B. Do not allow resilient base work to proceed until wall surfaces are satisfactory.
- C. Do not start work until painting has been completed.

SPECIAL PROVISION SECTION 763 – BUS PAVILION AND/OR
SECTION 999 – ARCHITECTURAL CONSTRUCTION MAINTENANCE BUILDING
RESILIENT BASE

2

3.02 PREPARATION

- A. Use patching compounds as recommended by resilient base manufacturer for filling small cracks, holes and depressions in wall surfaces to receive base.
- B. Remove coatings from wall surfaces that will prevent adhesive bond, including compounds incompatible with resilient base adhesives, paint, oils, waxes and sealers.

3.03 INSTALLATION**A. Installation General:**

- 1. Install resilient base using method indicated in strict compliance with manufacturer's printed instructions. Extend resilient base into spaces, reveals, and similar openings.
- 2. Use prefabricated inside and outside corners.

B. Installation of Base:

- 1. Apply wall base to walls where base is required. Install base in lengths as long as practicable, with preformed corner units, or fabricated from base materials with mitered or coped inside corners. Tightly bond base to substrate throughout length of each piece with continuous contact, using weights as necessary, at horizontal and vertical surfaces.
- 2. On masonry surfaces, or other similar irregular substrates, fill voids along top edge of resilient wall base with manufacturer's recommended adhesive filler material.

3.04 CLEANING AND PROTECTION

- A. Do not wash base until time period recommended by resilient base manufacturer has elapsed to allow resilient base to become well-seated in adhesive.
- B. Damp-mop base being careful to remove black marks and excessive soil.
- C. Remove excess adhesive or other surface blemishes, using appropriate cleaner recommended by resilient base manufacturer.
- D. Protect base against damage during construction period to comply with resilient base manufacturer's directions.
- E. Replace all damaged base at no cost to Department.

3.05 EXTRA STOCK

- A. Deliver stock of maintenance materials to Department. Furnish maintenance materials from same manufactured lot as materials installed and enclosed in protective packaging with appropriate identifying labels.
 - 1. Resilient Base: Ten Percent of Total Amount Installed in 4 foot lengths.

3.06 PAYMENT

- A. Lump sum price for Bus Pavilion and Architectural Construction Maintenance Building covers all items of work in this Special Provision including furnishing labor, materials, tools, equipment, and incidentals required to complete the work.

END OF SECTION

State Road and Tollway Authority (SRTA), State of Georgia

SPECIAL PROVISION

Section 763 – Bus Pavilion and/or Section 999 – Architectural Construction Maintenance Building

Section 099100 – Painting

PART 1 – GENERAL

1.01 WORK INCLUDED

- A. This Section includes the surface preparation and application of painting and related work in locations indicated on the Drawings and specified herein.

1.02 RELATED WORK

- A. CONCRETE FORMING AND ACCESSORIES: Section 03 10 00.
- B. CONCRETE UNIT MASONRY: Section 04 22 00.
- C. METAL FABRICATIONS: Section 05 50 00.
- D. JOINT SEALANTS: Section 07 92 00.
- E. METAL DOORS AND FRAMES: Section 08 11 00.

1.03 QUALITY ASSURANCE

- A. All surfaces of fabricated items that are left unfinished by the requirements of other Sections shall be painted under this Section. All work specified in this Section shall be in addition to shop and mill coats, priming and field coats which are specified in other Sections.
- B. Perform all touching up of shop coats and field coats of paint on structural steel and miscellaneous steel or iron as required and/or specified.
- C. Aluminum, steel, stainless steel, copper, bronze, chromium plating, nickel, monel metal, lead, lead coated copper and other surfaces with factory finishes shall not be painted or finished, except as otherwise specified.
- D. Remove and re-finish or otherwise correct in a manner approved by Engineer all work under this Section which peels, crazes, blisters, fails to adhere or otherwise fails to properly serve its intended purpose at no additional cost to the Department.

1.04 PRODUCT DELIVERY AND STORAGE

- A. All materials shall be delivered to the Project site in manufacturers' sealed packages, with labels intact.

SPECIAL PROVISION SECTION 763 – BUS PAVILION AND/OR
SECTION 999 – ARCHITECTURAL CONSTRUCTION MAINTENANCE BUILDING
PAINTING

1

1.05 SUBMITTALS

- A. **Product Data:** Submit manufacturer's product data for each type of product used.
- B. **Samples:** Submit three (3) sets of full color chip line for each type of paint specified, for color selection(s) by the Engineer.
- C. **Draw Downs:** Provide three (3) stepped draw downs, defining each separate coat, including block fillers and primers, for each color and material to be applied.

PART 2 – PRODUCTS

2.01 MATERIALS

- A. All ready-mixed paints shall be first-line (best quality grade) retail products. The use of lead-containing paint is NOT permitted.
- B. Thinners and additives shall be of types recommended by the paint manufacturer.
- C. **Products:** Paint materials and systems specified herein are produced by Sherwin-Williams (S-W). Subject to compliance with requirements, equivalent paint materials and systems by one of the following manufacturers are also acceptable:
 1. Benjamin Moore.
 2. ICI Dulux.
 3. Porter Paints.
 4. PPG Architectural Finishes, Inc.
 5. Pratt & Lambert.

PART 3 – EXECUTION

3.01 INSPECTION

- A. Examine the areas and conditions under which painting is to be applied. Do not proceed with painting work until unsatisfactory conditions have been corrected.

3.02 COLORS

- A. The Architect will select all colors based on the color scheme defined by the Authority, and provide a schedule of colors and finishes as approved by the Authority.
- B. Each coat of paint shall be applied in varying shades, with the final coat matching the approved color selected.

3.03 PREPARATION FOR PAINTING

- A. Surfaces to be painted shall be clean, smooth, free from scratches and dust and thoroughly dry. Wood surfaces shall be well sanded before painting work is started.

SPECIAL PROVISION SECTION 763 – BUS PAVILION AND/OR
SECTION 999 – ARCHITECTURAL CONSTRUCTION MAINTENANCE BUILDING
PAINTING

2

- B. Concrete surfaces shall be cleaned, grouted, rubbed and pointed, water flushed clean and free of all dust, oily grease and laitance, and allowed to dry prior to painting.
- C. Steel and Iron shall be free from grease, rust, scale and dust. Touch up any chipped or abraded places on items that have been shop coated. Where steel and iron have heavy coating of scale, it shall be removed by wire brush or sand blasting necessary to produce a satisfactory surface for painting.

3.04 PROTECTION

- A. Adjacent fixtures and hardware shall be removed during the painting application.
- B. Particular care shall be taken by the use of clean drop cloths, masking and other suitable means, to protect adjoining surfaces, fixtures, and materials of all kinds. Painting applicator shall be held responsible for, and shall repair, all damages resulting from the painting operation.
- C. All ceiling and soffit overhead painting shall be applied only while the floor is completely and continuously covered with drop cloths.

3.05 APPLICATION

- A. Paints shall be applied in the colors and minimum number of coats scheduled herein and at the square foot coverage as stated in the paint manufacturer's printed specifications. It is intended that paint so applied shall cover to the satisfaction of the Engineer or additional coats shall be applied until approval is obtained.
- B. Paints shall not be applied to surfaces which show a moisture content greater than 15 percent as determined by an electronic moisture meter.
- C. Paints shall not be applied when the temperature falls below 45 degrees F., in damp, rainy weather, or when the relative humidity exceeds 85 percent.
- D. Paint shall be evenly spread and well distributed. The finish coats shall be free from any noticeable laps, brush marks, streaks, runs, sags, wrinkles, and shiners.

3.06 BACK PRIMING

- A. All wood backs to be placed against concrete or masonry (except pressure treated wood) shall be painted with a sealer coat of paint or clear varnish before installation

3.07 DESTROYING WASTE

- A. At the end of each day, all cloths and waste materials that have been used in preparation and application of inflammable paint materials shall be destroyed or placed in closed metal containers. Under no circumstances shall any waste be emptied into plumbing fixtures, drains, or clean-outs of the plumbing systems of the building. Waste shall not be allowed to accumulate on the Site.

3.08 TOUCH UP AND CLEANING

- A. Upon completion, all touching-up as required shall be applied and any paint shall be removed from all surfaces that are not specified to receive paint.

3.09 PAINTING OF PIPING FOR IDENTIFICATION

- A. Exposed piping, piping concealed in accessible pipe spaces and piping behind access panels shall be identified to designate service.
- B. Legend shall be stencil applied (painted on) at 40 feet spacing on straight runs where pipes pass through walls or floors and regulators, strainers, and clean-outs (except valves and fittings on plumbing fixtures and equipment).
- C. Legend shall give name in full or abbreviations. Size of stenciled identity lettering shall vary with the diameter of pipe covering as follows:
 - 1. Up to 1" 1/2" high letters.
 - 2. Above 1" 3/4" high letters.

3.10 PAINTING SCHEDULE

- A. Trade Names used are only to set a standard of quality desired.
- B. Omit primer on items with shop coat primer. All shop coats shall be touched up with the same kind of paint as the shop coat and allowed to dry before application of finish coats.
- C. The following surfaces shall be finished with the designated number of coats (in addition to shop or manufacturer's coats) with the respective designated products of Sherwin Williams (SW), with a Dry Film Thickness (DFT) of not less than indicated:

EXTERIOR

- 1. Metal, Galvanized: Gloss Finish.
 - a. 1-coat SW Water Based Catalyzed Epoxy Primer: 3.0 - 5.0 DFT
 - b. 2-coats SW Corothane II: 2.0 - 4.0 DFT each coat.
 - c. Total 7.0 - 13.0 DFT.
- 2. Metal, Ferrous: Gloss Finish.
 - a. 1-coat SW Tile-Glad High Solids: 2.5 - 4.0 DFT
 - b. 2-coats SW Corothane II : 2.0 - 4.0 DFT each coat.
 - c. Total 6.5 - 12.0 DFT.

INTERIOR

- 1. Metal, Galvanized: Eggshell Finish.
 - a. 1-coat SW Hi-Solids Alkyd Metal Primer: 3.0 - 5.0 DFT.
 - b. 2-coats SW ProMar 200 Alkyd Eg-Shel Enamel: 1.8 DFT each coat.
 - c. Total 6.6 - 8.6 DFT.
- 2. Metal, Ferrous: Eggshell Finish.

SPECIAL PROVISION SECTION 763 – BUS PAVILION AND/OR
SECTION 999 – ARCHITECTURAL CONSTRUCTION MAINTENANCE BUILDING
PAINTING

4

- a. 1-coat SW Hi-Solids Alkyd Metal Primer: 3.0 - 5.0 DFT.
 - b. 2-coats SW ProMar 200 Alkyd Eg-Shel Enamel: 1.8 DFT.
 - c. Total 6.6 - 8.6 DFT.
3. Piping and Conduit, Exposed Surfaces: Semi-Gloss Finish.
- a. Ferrous Metal:
 - 1) 1-coat SW Hi-Solids Alkyd Metal Primer: 3.0 - 5.0 DFT.
 - 2) 2-coats SW ProMar 200 Interior Alkyd Semi-Gloss Enamel: 1.5 DFT each coat.
 - 3) Total 6.0 - 8.0 DFT.
 - b. Aluminum and Galvanized Metal:
 - 1) 1-coat SW Hi-Solids Alkyd Metal Primer: 3.0 - 5.0 DFT.
 - 2) 2-coats SW ProMar 200 Interior Alkyd Semi-Gloss Enamel: 1.5 DFT each coat.
 - 3) Total 6.0 - 8.0 DFT.
4. Masonry and Concrete: Eggshell Finish.
- a. 1-coat SW PrepRite Block Filler: 8.0 DFT.
 - b. 2-coats SW ProMar 200 Alkyd Eg-Shel Enamel: 1.8 DFT each coat.
 - c. Total 11.6 DFT
5. Plywood for Opaque Eggshell Finish: Each coat of enamel applied and re-rolled to achieve uniform stipple.
- a. 1-coat SW ProBlock Interior/Exterior Latex Primer Sealer: 1.4 mils DFT.
 - b. 2-coats SW MPI-52 Gloss Level 3 Interior Latex Eg-Shel: 1.5 mils DFT each coat.
 - c. Total 4.4 mils DFT

3.11 PAYMENT

- A. Lump sum price for Bus Pavilion and Architectural Construction Maintenance Building covers all items of work in this Special Provision including furnishing labor, materials, tools, equipment, and incidentals required to complete the work.

END OF SECTION

SPECIAL PROVISION SECTION 763 – BUS PAVILION AND/OR
SECTION 999 – ARCHITECTURAL CONSTRUCTION MAINTENANCE BUILDING
PAINTING

5

State Road and Tollway Authority (SRTA), State of Georgia

SPECIAL PROVISION

Section 763 – Bus Pavilion and/or Section 999 – Architectural Construction Maintenance Building

Section 104416 – Fire Extinguishers

PART 1 – GENERAL

1.01 WORK INCLUDED

- A. Work of this Section shall include the following:
 - 1. Fire Extinguishers
 - 2. Brackets
 - 3. Accessories

1.02 RELATED WORK

- A. CONCRETE UNIT MASONRY: Section 04 22 00.

1.03 QUALITY ASSURANCE

- A. Reference Standards:
 - 1. National Fire Protection Association (NFPA):
 - a. NFPA 10 - Portable Fire Extinguishers.
- B. Single Source Responsibility:
 - 1. Provide fire extinguishers, brackets, and accessories by single manufacturer.
- C. Requirements of Regulatory Agencies:
 - 1. All fire extinguishers shall be Underwriters' Laboratories (UL) approved and labeled.

1.04 SUBMITTALS

- A. Product Data:
 - 1. Submit manufacturer's technical data and installation instructions for fire extinguishers and accessories.

SPECIAL PROVISION SECTION 763 – BUS PAVILION AND/OR
SECTION 999 – ARCHITECTURAL CONSTRUCTION MAINTENANCE BUILDING
FIRE EXTINGUISHERS

1

PART 2 – PRODUCTS**2.01 ACCEPTABLE MANUFACTURERS**

- A. **Products:** Provide fire extinguishers and accessories by one of the following manufacturers:
1. J.L. Industries, Inc.
 2. Larsen's Manufacturing Co.
 3. Potter-Roemer

2.02 FIRE EXTINGUISHERS

- A. Fire extinguishers shall be multi-purpose, dry chemical type, 10-pound capacity.
- B. **Products:** Provide one of the following fire extinguishers:
1. "MP 10"; Larsen's Manufacturing Co.
 2. "Cosmic 10E"; J.L. Industries, Inc.
 3. "3000" Series; Potter-Roemer
- C. Brackets shall be used for all fire extinguishers. For interior installations, provide Larsen's "#546" or equivalent.

PART 3 – EXECUTION**3.01 INSPECTION**

- A. Verify servicing, charging, and tagging of all fire extinguishers.

3.02 INSTALLATION

- A. Install the items of this Section in strict accordance with the original design, approved Shop Drawings, NFPA 10, and requirements of agencies having jurisdiction, as approved by the Engineer, anchoring all components firmly into position.
1. **Fire Extinguisher Locations:** As indicated on Drawings.

3.03 PAYMENT

- A. Lump sum price for Bus Pavilion and Architectural Construction Maintenance Building covers all items of work in this Special Provision including furnishing labor, materials, tools, equipment, and incidentals required to complete the work.

END OF SECTION

**SPECIAL PROVISION SECTION 763 – BUS PAVILION AND/OR
SECTION 999 – ARCHITECTURAL CONSTRUCTION MAINTENANCE BUILDING
FIRE EXTINGUISHERS**

2

State Road and Tollway Authority (SRTA), State of Georgia

SPECIAL PROVISION

Section 999 – Architectural Construction Maintenance Building

Section 230500 – General HVAC Requirements

PART 1 - GENERAL

1.1 SUMMARY

- A. This Section specifies general mechanical requirements for all Division 23 – HEATING, VENTILATING, AND AIR CONDITIONING (HVAC) Specification Sections.
- B. Drawings and Specifications: The Drawings and Specifications shall be considered as complementary, one to the other, so that materials and work indicated, called for, or implied by the one and not by the other shall be supplied and installed as though specifically called for by both. The Drawings are to be considered diagrammatic, not necessarily showing in detail or to scale all of the equipment or minor items. In the event of discrepancies between the Drawings and the Specifications, or between either of these and any regulations or ordinances governing mechanical work, notify the Engineer in ample time to permit revisions.

1.2 RELATED WORK

- A. TEST AND BALANCE: Section 230593.
- B. PIPING AND SPECIALTIES: Section 232000.
- C. DUCTLESS SPLIT HEAT PUMP AC SYSTEMS: Section 238119
- D. DIVISION 26 - ELECTRICAL Sections.

1.3 CODES AND STANDARDS

- A. The codes and standards covering mechanical work include, but are not limited to:
 - 1. American National Standards Institute (ANSI).
 - 2. American Society for Testing and Materials (ASTM).
 - 3. American Society of Heating, Refrigeration and Air Conditioning Engineers (ASHRAE).
 - 4. American Society of Mechanical Engineers (ASME).
 - 5. American Welding Society (AWS).

6. International Building Code - Mechanical and Plumbing, Latest Adopted Edition, as amended.
 7. National Electrical Manufacturers Associations (NEMA).
 8. National Fire Protection Association (NFPA).
 - a. NFPA 30 Flammable and Combustible Liquids Code.
 - b. NFPA 58 Storage and Handling of Liquefied Petroleum.
 - c. NFPA 90A Installation of Air Conditioning and Ventilating Systems.
 - d. NFPA 90B Installation of Warm Air heating and Air Conditioning Systems
 - e. NFPA 101 Life Safety Code.
 9. National Sanitation Foundation (NSF).
 10. Sheet Metal and Air Conditioning Contractors National Association (SMACNA).
 11. Codes, Regulations, Ordinances, and similar regulatory requirements, of all governing authorities having jurisdiction over this Work.
- B. These codes, society and association recommendations constitute minimum requirements and no reductions from design requirements will be permitted, even if allowed by the applicable codes, without expressed written permission of the Engineer.

1.4 SHOP AND ERECTION DRAWINGS

- A. Submit required and requested shop and erection drawings for review by Engineer before ordering or installing any equipment or material. Equipment or material ordered or installed before Engineer's review may not be accepted and will have to be removed from the Project.
- B. Shop drawings shall consist of manufacturer's scale drawings, cuts or catalogs, including descriptive literature which shall clearly indicate the construction, material, physical dimensions, wiring diagrams and complete operating data clearly marked for each item. Data of general nature will not be accepted.
- C. Erection drawings shall consist of 1/4" scale drawings of the work including foundations in plan and elevation. These drawings shall show clearances between units and relation of equipment to space assigned and to the work of other trades. Normally, with the exception of drawings for ductwork, erection drawings are required for mechanical equipment rooms. Provide drawings for other area requested by the Engineer.
- D. Prior to making any changes in the Work that is shown on the Contract Drawings, prepare and submit to the Engineer a drawing with a minimum of 1/4" scale showing proposed change. Do not proceed with the change without a written approval by the Engineer. All such approved drawings shall be included into final set of record drawings.
- E. The Engineer's approval of shop drawings does not relieve the Contractor of their responsibility to comply with all requirements of this Specification.

1.5 RECORD DRAWINGS

- A. Record Drawings shall be submitted to the Engineer before Final Acceptance and shall include the following as a minimum requirement:
 1. Factory programmed with capability to field reprogram set points per Owner preferences.
 2. Lead/Lag controller to be programmed to operate both HVAC units to insure equal wear on both units while allowing the Lag unit to assist upon demand.

1.6 FEES, PERMITS AND INSPECTIONS

- A. Obtain all permits for work under this Contract and pay all expenses in conjunction therewith. Also, procure and deliver to the Engineer all certificates issued by the authorities having jurisdiction.
- B. The work will be observed by the Owner during the course of construction. Provide for inspection by others having jurisdiction during the proper phases.

1.7 DELIVERY, STORAGE AND HANDLING

- A. Deliver materials to Project site at such intervals to ensure uninterrupted progress of work.
- B. Deliver anchor bolts, anchorage devices, and sleeves which are to be embedded in cast-in-place concrete or masonry, in ample time not to delay work.
- C. Store materials to permit easy access for inspection and identification. Keep steel members off ground, using pallets, platforms, or other supports. Protect steel members and packaged materials from corrosion and deterioration.
- D. Do not store materials on structure in a manner that might cause distortion or damage to members or support structures. Repair or replace damaged materials or structures as directed at no additional cost to the Owner.

PART 2 - PRODUCTS

2.1 GENERAL

- A. Materials or products specified herein and/or indicated on Drawings by trade name, manufacturer's name and/or catalog number shall be provided as specified.
- B. Since manufacturers reserve the right to change their products at anytime, verify all dimensions, performance data, and similar criteria for each piece of equipment submitted to ensure compliance with the intent of the Drawings and Specifications.
- C. All materials shall be new of the quality specified.
- D. Deviations mean the use of any listed approved manufacturer other than those on which the Drawings are based.

2.2 SPACE AND ACCESS TO EQUIPMENT

- A. All equipment shall fit the allotted space and shall leave reasonable access room for servicing and repairs. Greater space and room required by substituted equipment shall be provided by the Contractor at no additional cost to the Owner
- B. Provide access panels to service and maintenance devices such as cleanouts, air vents, service valves, air volume balancing dampers, fire dampers, and similar items that are installed in concealed spaces.

2.3 CUTTING AND PATCHING

- A. Unless otherwise indicated on the Mechanical Drawings, perform all cutting and patching necessary for the Work. Where interferences occur, and departures from indicated arrangements are required, coordinate the mechanical work with the other trades involved and make a determination as to changed locations and elevations of the ductwork and/or piping and shall obtain approval from the Engineer for the proposed changes.

2.4 SAFETY REQUIREMENTS

- A. In addition to the components specified and shown on the Drawings and necessary for the specified performance, incorporate in the design and show on the shop drawings all the safety features required by the current codes and regulations, including but not limited to those of the Occupational Safety and Health Act of 1970, and Amendments thereto.

2.5 ELECTRICAL WORK

- A. Furnish all control wiring and conduit for the HVAC equipment and include control devices such as thermostats, control switches, contactors, relays and starters. All Work shall conform in all respects to the requirements of the applicable requirements of Division 26 Specifications.

2.6 CLEANING AND PROTECTING

- A. During construction protect all piping and equipment from damage and dirt. Cap the open ends of all piping and equipment.
- B. After completion of Project, clean the exterior surface of equipment included in this Section, remove all residues and as directed touch up paint or completely repaint all damaged surfaces.

2.7 PAINTING

- A. All equipment shall have factory standard finish, except as specifically indicated herein. Where zinc chromate paint is specified it shall be formulated using a synthetic resin vehicle.
- B. Ironwork installed under this Division of the Specifications exposed to view within the building, and not otherwise specified to be painted, galvanized, copper or chrome plated, such as piping, pipe hangers, structural supports, supports for apparatus, black iron

partitions or casings, tanks, and similar items shall be painted with one coat of zinc chromate primer.

2.8 EQUIPMENT IDENTIFICATION

- A. Identify each unit by its system number and other appropriate designation by engraved plastic nameplates in letters of approved size and wording. Equipment requiring identification shall include packaged and split system air conditioning units and heating unit.

2.9 WATERPROOFING

- A. Where any work pierces waterproofing, including waterproof concrete, the method of installation shall be as approved by the Engineer before work is performed.
- B. Provide all necessary sleeves, caulking and flashing required to make openings absolutely watertight. Waterproof flashing materials shall be compatible with base materials.

PART 3 - EXECUTION

3.1 EXAMINATION

- A. Where the contact of dissimilar metals may cause electrolysis and where copper will contact concrete, mortar or plaster, separate metal contact surfaces with not less than one coat of zinc chromate primer and one heavy coat of aluminum pigmented asphalt paint on each surface; or where deemed necessary by the Engineer, not less than open course of asphalt saturated cotton fabric cemented to both metals with flashing cement, shall be used. Completed work shall be cleaned and excess cement removed.

3.2 TESTS AND INSPECTIONS

- A. Provide equipment start-up procedures in accordance with manufacturer's recommended guidelines and installation checklist. Provide factory certifications where required for warranty purposes.
- B. Include all tests and inspections specified and/or required under laws, rules and regulations of all departments having jurisdiction. Tests shall be performed as indicated herein and other Sections of Specifications.
- C. Refer to TSP Section 23 05 93 – TEST AND BALANCE, for additional HVAC test and inspection procedures.
- D. Notify the Engineer at least 72 hours in advance of all tests. Furnish all necessary instruments, gauges and other equipment required for tests. Make preliminary tests prior to giving notice of final tests.
- E. All parts of the work and associated equipment shall be tested and adjusted to work properly and be left in perfect operating condition.

- F. Correct defects disclosed by these tests without any additional cost to the Owner Repeat tests on repaired or replaced work.
- G. Maintain separate log of all tests being conducted and have it available for review by Engineer. Log to indicate date, type of tests, duration and defects noted and when corrected.
- H. The Building Inspection/Permitting Agency shall perform acceptance and inspection of mechanical and plumbing systems. In addition, obtain Final Acceptance of mechanical and plumbing systems from the Owner's Representative.

3.3 ACCEPTANCE INSPECTION

- A. Representatives of installers responsible for work under this Division shall be present at time of acceptance inspections and shall furnish required mechanics, tools, and ladders to assist in the inspection.
- B. As a precedent to requesting a final inspection, the following steps shall be met:
 1. Complete all work under this Section of the Specifications.
 2. Have each system balanced to assure design performance. (See Section 230593 - TEST AND BALANCE for detailed requirements.)
 3. Furnish the Engineer with letter from an authorized representative of the equipment manufacturer certifying that all work has been checked for operation and calibration and that the system is operating as intended.
 4. Clean all dirty cooling coils and other equipment that may have accumulated dirt during construction.
- C. A list of items to be corrected as a result of acceptance inspection will be furnished to the installer. Notify Engineer in writing of any items appearing on list of correction that are disputed by installer. When ready, request in writing a re-inspection of Work.
- D. Provide certification that all work is in conformance with all codes and standards by the governing agencies having jurisdiction of the work.
- E. Provide hard copy of HVAC equipment parts manual prior to Final Acceptance of the building by Owner. Provide one (1) complete hard copy to remain in each building for future use.

3.4 OPERATING AND MAINTENANCE INSTRUCTIONS

- A. **Bound Instructions:** Before final payment is made, furnish 6 sets of bound operation and maintenance manuals to the Owner The manuals shall consist of catalog cuts, bulletins, shop drawings, wiring diagrams, schedules, parts lists, procedures and other data showing the equipment installed and shall include the following:
 1. Approved wiring and control diagrams, with data to explain the detailed operation and control of each component.
 2. A control sequence describing startup, operation and shutdown.

3. Operating and maintenance instructions for each piece of equipment, including lubrication instructions.
 4. Parts lists and recommended spare parts.
 5. Other data and instructions as specified under the various Sections.
- B. All data furnished shall conform to the installation as constructed. Cuts showing other equipment and data not applicable to the installation shall be crossed out and where practical shall be omitted from the manual. The assembly of the manual shall be in a logical manner and each section shall be indexed in the Table of Contents.
 - C. After each manufacturer has outlined a maintenance procedure for that manufacturer's equipment installed, compile these procedures in a logical manner to provide a procedure for the operating personnel of the Owner to follow in their day to day operation of the facility.
 - D. The materials shall be permanently bound into each booklet between rigid plastic or cloth binding covers. The instruction booklets shall be approximately 9-inches by 12-inches and the diagram booklet large enough to contain the drawing without excessive folding so that they may be easily opened.
 - E. The booklets shall be neatly entitled with a descriptive title, the name of the job, the location, year of installation, Department, Manufacturer, Contractor and Engineer. Copies of drawings shall be in black and white background and shall be easily legible. The arrangements of the booklets, the method of binding, materials to be included and the composite text shall all be reviewed and approved by the Engineer.

3.5 OPERATIONS INSTRUCTION TO OWNER

- A. Provide a minimum of 1 hour of instruction to representatives of Owner in operation and maintenance of all installed mechanical systems and equipment.
- B. Provide maintenance manual and acquaint Owner's representative with its contents during instruction.
- C. Furnish letter naming Owner's personnel receiving instruction and dates when instruction was given.
- D. Provide name, address and telephone number of the manufacturer's representative and service company, for each piece of equipment so that service or spare parts can be readily obtained.

3.6 PAYMENT

- A. The lump sum price for Building Complete covers all items of work in this Special Provision including furnishing labor, materials, tools, equipment, and incidentals required to complete the work.

END OF SECTION

State Road and Tollway Authority (SRTA), State of Georgia

SPECIAL PROVISION

Section 999 – Architectural Construction Maintenance Building

Section 230593 – Test and Balance

PART 1 - GENERAL

1.1 SUMMARY

- A. Procure the services of an independent Test and Balance Agency, approved by the Engineer, which specializes in the balancing and testing of heating, ventilating, and air conditioning systems.
- B. Agency to balance, adjust, and test following systems and/or equipment:
 - 1. Air distribution systems including air handling units and air devices on unit.
- C. As soon as possible after receipt of this Contract, allow the Test and Balance Agency to schedule it's work in cooperation with other trades involved and comply with the completion date(s) or calendar days required for completion, as specified.

1.2 RELATED WORK

- A. GENERAL HVAC REQUIREMENTS: Section 230500.
- B. DUCTLESS SPLIT HEAT PUMP AC SYSTEMS: Section 238119.

1.3 QUALITY ASSURANCE

- A. The Test and Balance Agency shall submit proof of having successfully completed at least five (5) projects of similar size and scope, and shall be certified as conforming to the standards and guidelines of the Associated Air Balance Council (AABC), unless otherwise approved.
- B. All instruments used shall be accurately calibrated within six months of balancing and maintained in good working order. If requested, the test shall be conducted in the presence of the Engineer and/or his representative.

1.4 SUBMITTALS

- A. Complete report of the test and balance data.
- B. Test and Balance Agency qualifications.

1.5 AIR BALANCE SCOPE

- A. The codes and standards covering mechanical work include, but are not limited to:
1. Test and adjust **RPM** to original requirements.
 2. Test and record motor full load amperes.
 3. Test and adjust system for original design **CFM** recirculated air.
 4. Test and record entering air temperatures. (**D.B.** cooling)
 5. Test and record entering air temperatures. (**W.B.** cooling)
 6. Test and record leaving air temperatures. (**D.B.** cooling)
 7. Test and record leaving air temperatures. (**W.B.** cooling)
 8. Test and Balance Agency shall check all controls for proper calibrations and list all controls requiring adjustments including sequence of operations. The Test and Balance Agency shall provide list by Contractor for adjustments and/or clarification by the Engineer.
 9. Test and Balance Agency shall check and verify the dual unit controller is switching over from **Lead** unit to **Lag** upon loss of power and returning to **Lead** unit once the power is restored. Confirmation/documentation of test will be required in writing as part of the report.
 10. After the completion of the equipment Test and Balance, provide temperature and humidity level readings every 15 minutes for a duration of not less than 1 hour. These readings shall be recorded with the door closed and no work being performed in the building.

1.6 TEST BALANCE REQUIREMENTS

- A. All testing shall be performed with the building empty of workers and with the door closed at all times.
- B. The testing shall begin after the building temperature/conditions have stabilized to obtain maximum accuracy of the report findings.
- C. All information required as shown but not listed to shall be compiled in a neat, orderly itemized format on **AABC Test Forms**. All test data shall be submitted to the Engineer.

1.7 EVAPORATOR COIL

- A. Mark Number.
- B. Total Supply Air **CFM** original Specified and Actual.
- C. Return Air **CFM** original Specified and Actual.
- D. Cooling - Return and Supply Air **DBF** and **WBF** originally Specified and Actual.

- E. Motor HP originally Specified and Actual.
- F. Motor and Fan RPM originally Specified and Actual.
- G. Voltage, Phase and Cycles originally Specified and Actual.

1.8 AIR DEVICES (GRILLES AND REGISTERS ON AHU)

- A. AHU Number.
- B. CFM Specified and Actual.

PART 2 - EXECUTION

2.1 GENERAL

- A. Air balance and testing shall not begin until modifications to the system have been completed and the system is in full working order. Mechanical systems installer shall make all preliminary tests and adjustments, shall place all systems and equipment into full operation and continue the operation during each working day of testing and balancing.
- B. Replacement of fittings, AC unit components and similar items required to effect proper air balance or operate the system shall be furnished and installed by the mechanical HVAC installer at no additional cost to the Owner.
- C. Test and Balance Agency shall furnish the Contractor and Engineer at the end of each day a list of items that must be repaired or adjusted.
- D. This work shall be performed as soon as possible so as not to delay the completion of the test and balance work.
- E. Submit complete report of the test and balance data of air conditioning, heating, and ventilating systems for review by the Engineer and Engineer of Record.
- F. All air filters shall be replaced by the mechanical HVAC Installer before the test and balance work can proceed and thereafter as required by the Test and Balance Agency.
- G. Lock in place all accessories after final adjustments are made and permanently mark the set point of adjustment.

2.2 PAYMENT

- A. The lump sum price for Building Complete covers all items of work in this Special Provision including furnishing labor, materials, tools, equipment, and incidentals required to complete the work.

END OF SECTION

State Road and Tollway Authority (SRTA), State of Georgia

SPECIAL PROVISION

Section 999 – Architectural Construction Maintenance Building

Section 232000 – Piping and Specialties

PART 1 - GENERAL

1.1 SUMMARY

- A. Furnish and install the condensate drainage, domestic water and refrigerant piping systems complete with all supports, hangers, specialties, and accessories as shown on and herein specified.
- B. Provide new materials free from defects and of American manufacture, clearly marked with manufacturer's name and weight, classification, or working pressure of pipe and fitting.

1.2 RELATED WORK

- A. GENERAL HVAC REQUIREMENTS: Section 230500.
- B. DUCTLESS SPLIT HEAT PUMP AC SYSTEM: Section 238119.

1.3 SUBMITTALS

- A. Submit manufacturer's technical data sheets and shop drawings for approval on all pipe, fittings, valves, hangers, sleeves and specialties as listed in this Technical Special Provision before any work is commenced. Submit piping erection drawings.

1.4 DELIVERY, STORAGE AND HANDLING

- A. Provide factory-applied plastic end-caps on each length of pipe and tube. Maintain end-caps through shipping, storage and handling as required to prevent pipe-end damage and eliminate dirt and moisture from inside of pipe and tube.

Where possible, store pipe and tube inside and protected from weather. Where necessary to store outside, elevate above grade and enclose with durable, waterproof wrapping.

- B. Protect flanges and fittings from moisture and dirt by inside storage and enclosure, or by packaging with durable, waterproof wrapping.

PART 2 - PRODUCTS

2.1 PIPE

- A. The following schedule covers the materials which shall be furnished and installed unless otherwise specified under the particular system section:

SPECIAL PROVISION SECTION 999 – ARCHITECTURAL CONSTRUCTION
MAINTENANCE BUILDING - PIPING AND SPECIALTIES

1

MATERIALS

1. PVC pipe, DWV, Sch. 40
2. Soft Copper Tube Type K
3. Soft Copper Tube Type L
4. Seamless Type "L" Copper

SERVICE

Condensate piping / Piping Sleeve
 Above Grade Domestic Water
 Below Grade Domestic Water
 Refrigerant piping for aboveground
 and piping running in pipe sleeves.

2.2 PIPE, FITTINGS, INSULATION

- A. **PVC Pipe:** Schedule 40, DWV pipe and fittings for condensate drainage shall conform to ASTM F 891. All PVC socket type connections shall be made with PVC solvent cement complying with ASTM D 2665, made to ASTM D 3311.
- B. **Soft Copper Tube:** ASTM B 88, Type K below grade water tube, annealed temper.
- C. **Soft Copper Tube:** ASTM B 88, Type L above grade water tube, annealed temper.
- D. **Pipe Insulation:** Refrigerant and aboveground domestic water piping, provide 3/4" closed cell elastomeric Armstrong Armaflex or equal, suitable for operating temperatures from - 40 F to 200 F. Flame spread rating of less than 25 and a smoke density rating of less than 50 rated for return air plenum use. outdoor applications require aluminum jacket covering.
- E. **Dielectric Unions:** Dissimilar pipe metals shall be electrically insulated from each other by couplings, unions, or flanges commercially manufactured for that purpose and rated for the service pressure and temperature. Use of steel or cast-iron fittings in a copper piping system is prohibited, except where specifically noted. threaded unions shall be as manufactured by EPCO.
- F. **Water-Hammer Arresters:** Josam SA Lite Series with copper shell, piston type air cushion and male threaded connection. Conform to ASSE 1010, complies with lead free requirements, piston lubricated with FDA approved 111 silicone compound.
- G. **Refrigerant Piping:**
 1. Follow AC system manufacturer's recommendations for refrigerant lines sizing/installation. Provide all required equipment and accessories for a complete working system.
 2. Provide shielding for refrigerant piping in all exposed areas accessible to occupants or located outdoors.
 3. Follow AC system manufacturer's long run application recommendations for refrigerant lines sizing/installation. Provide all required equipment and accessories for a complete working system.

2.3 ESCUTCHEONS

- A. **Eescutcheons :** Provide stainless steel escutcheons securely in place on exposed pipes where they pass through walls, partitions floors and ceilings or finished areas.

2.4 SHUT-OFF VALVE

- A. **One-Piece, Bronze Ball Valve:**

1. Standard: MSS SP-110.
2. CWP Rating: 400 psig.
3. Body Design: One piece.
4. Body Material: Bronze.
5. Ends: Threaded.
6. Seats: PTFE.
7. Stem: Bronze.
8. Ball: Chrome-plated brass.
9. Port: Reduced.

2.5 PIPE HANGERS AND SUPPORTS

- A. Provide hangers and supports for the different applications as follows:
1. Plumbers strap shall not be used.
 2. Pipe Saddles: 18 gauge galvanized iron, 12 inches long (min.) installed at all points where insulated lines bear on hangers.
 3. Supports shall be generally capable of maintaining the installed load plus 500 lb. Support copper tubing at 6-foot (max.) intervals horizontally. Support PVC piping every 4 feet.

2.6 PIPE SLEEVES

- A. Interior: Galvanized sheet metal, 22 gauge. Provide for pipe passing through walls or floors before pouring concrete. Plastic sleeves are permitted.
- B. All sleeves shall be large enough to allow full thickness of insulation through sleeves for insulated piping, and for two layers of 30 lb. felt wrapping around un-insulated piping.

PART 3 - EXECUTION

3.1 GENERAL

- A. The Plans are generally diagrammatic. They do not show every bend, off-set, elbow or other fittings which may be required in the piping for installation in the space allotted. Careful coordination of the work of this Technical Special Provision with that of other Divisions is necessary to avoid conflicts.
- B. Line and Grade: Install gravity lines at uniform grade to low point after field verification of low point invert.

3.2 PIPE SLEEVES

1. Place all sleeves for piping prior to the pouring of concrete or in time to set in place as masonry walls are erected.
2. After piping is installed through the sleeves, complete with insulation or wrapping, the sleeves shall be sealed water-tight with an approved mastic or caulking compound.

3.3 JOINTING PIPE

- A. Provide nipples of same material and weight as pipe used. Part of standard weight nipples is less than 1-1/2 inches.

- B. Provide reducing fittings where changes in pipe sizes occur.
- C. Provide unions or flanges in all service lines at each piece of equipment, specialty, valves or at other locations required for ready disconnect.
- D. Provide all necessary drain piping from the low point of each of the systems, and other miscellaneous piping required by the various systems to make a complete installation. Drains shall not be smaller than connection at equipment and no drain shall be smaller than 3/4 inch.
- E. **PVC Pipe:**
 - 1. Remove all burrs from cut ends of PVC piping with knife, deburring tool or file.
 - 2. Visually inspect the inside of pipe and fitting sockets and remove all dirt, grease or moisture with chemical cleaner and wipe clean with cloth prior to application of solvent.
 - 3. All thermoplastic pipe installed underground shall be installed in accordance with ASTM D 2321.

3.4 PIPE HANGERS AND SUPPORTS

- A. Provide brackets, rolls, clamps and supplementary steel as required for proper support of pipe lines. Design hangers to allow for expansion and contraction of pipe lines and of adequate size to permit covering to run continuously through hangers. Support piping at equipment independently so that no weight will be supported by equipment. Coordinate location of hangers with light fixtures. Wire brush all steel or iron supports and prepare surfaces under this Technical Special Provision for painting.
 - 1. Special Supports: All clamps, hangers and supports required by equipment manufacturers, shall be furnished and installed as per their recommendations.
 - 2. Plumbers tape, straps, chain, wire hangers, or perforated bar shall not be allowed as a means for hanging pipe.

3.5 EQUIPMENT CONNECTIONS

- A. Make connections between equipment and the piping systems as shown and specified.
- B. Make connections between any piece of equipment and any piping system by means of unions, flange joints or other fittings which permit equipment to be disconnected and removed for maintenance.

3.6 PAYMENT

- A. The lump sum price for Building Complete covers all items of work in this Special Provision including furnishing labor, materials, tools, equipment, and incidentals required to complete the work.

END OF SECTION

State Road and Tollway Authority (SRTA), State of Georgia

SPECIAL PROVISION

Section 797 – Architectural Construction Maintenance Building

Section 238119 – Ductless Split Heat Pump AC System

PART 1 - GENERAL

1.1 WORK INCLUDED

- A. Furnish and install two (2) ductless split system air conditioning systems with a wired duplex controller/thermostat. Mount the air handler's high on an interior wall of the building, and mount the condensing units outside of the building. Provide controls, refrigerant piping, condensate drains, attachments, and accessories as specified herein, and shown on the plans.

1.2 RELATED SECTIONS

- A. 230500 - General HVAC Requirements
- B. 230593: Test and Balance
- C. 232000 - Piping and Specialties

1.3 QUALITY ASSURANCE

- A. Single Source Responsibility:
 - 1. Provide units by a single manufacturer, unless otherwise approved by the Engineer.
- B. Performance Requirements:
 - 1. Comply with performance requirements of the following:
 - a. Air-Conditioning & Refrigeration Institute (ARI) Standards:
 - ARI210 - Unitary Air-Conditioning Equipment.
 - ARI270 - Sound Rating of Outdoor Unitary Equipment.
 - b. American Society of Heating, Refrigerating, and Air Conditioning Engineers (ASHRAE)
 - c. ASHRAE 52 - Air-Cleaning Devices Used in General Ventilation for Removing Particulate Matter.
 - d. Underwriters' Laboratories (UL) Reference Standards.

1.4 ACTION SUBMITTALS

- A. Product Data: Submit manufacturer's product data and installation instructions for each air handling unit (AHU), and conditioning unit (CU). Include the rated capacity, sensible capacity, operating characteristics, rough-in dimensions (as applicable), rigging

procedures, service connection requirements, drain connections, performance ratings, materials, manufacturer's model numbers, power/electrical requirements, wiring diagrams showing connection points for the thermostat/duel unit controller.

- B. **Shop Drawings:** Include plans, elevations, sections, details, and attachments to other work.
 - 1. **Detail equipment assemblies** and indicate dimensions, weights, loads, required clearances, method of field assembly, components, and location and size of each field connection.
 - 2. **Wiring Diagrams:** For power, signal, and control wiring.

1.5 INFORMATIONAL SUBMITTALS

- A. **Product Test Reports:** Based on evaluation of comprehensive tests performed by manufacturer and witnessed by a qualified testing agency, for split AC systems.
- B. **Field quality-control reports.**
- C. **Warranty:** Sample of special warranty.

1.6 CLOSEOUT SUBMITTALS

- A. **Provide operation, maintenance and parts manuals in accordance with items 1 through 5 below.**
 - 1. **Provide one FLASH DRIVE copy and one paper book copy of the ductless split AC system manufacturer's parts manuals for each building under this contract.** The parts manuals must show the original equipment manufacturers part numbers for all parts and accessories included with the packaged terminal air conditioner units.
 - 2. **Provide one FLASH DRIVE copy and one paper book copy of the ductless split AC system manufacturer's service and repair manuals for each building under this contract.**
 - a. The service and repair manuals shall include the manufacturer's suggested preventive maintenance service activities, suggested intervals between each service, and the required parts and tools to perform the service.
 - b. The service and repair manual will include separate chapters on each subsystem or major component of the ductless split AC systems. Each chapter will provide exploded view diagrams, required tools, and step by step procedures to repair or replace each component in the subsystem.
 - 3. Turn over the **FLASH DRIVE** and paper parts manual book and the **FLASH DRIVE** and paper service manual book to the Construction Engineering & Inspection (CEI) firm when the site is turned over to the Owner for installing the tolling equipment.
 - 4. The Construction Engineering & Inspection representative will accept the paper and **FLASH DRIVE** copy of the manuals and provide a written receipt to the contractor to show that the manuals were received and are awaiting review. The contractor will submit an electronic copy of the manuals to the Owner for review as a Shop Drawing.

5. If the manuals are incomplete, or are lacking in meaningful parts information or step by step repair instructions, or do not cover the model or type of equipment being provided, then the Owner may REJECT the manuals and indicate on the shop drawing review forms the nature of the deficiencies. The contractor will then collect the deficient materials from the CEI, correct the deficiencies, and then re-submit the materials for another review.

1.7 Submit a written copy of the warranty for each Air Conditioner system. Ensure the owner is listed, with the physical address of the toll equipment building that the unit is being installed in. Ensure the physical address shown on the warranty is the same address as shown on the toll building utility bill. **DELIVERY, STORAGE, AND HANDLING**

- A. Deliver ductless split AC system (s) in factory-fabricated containers designed to protect units and finish until final installation.
- B. Store ductless split AC system (s) in original containers and in location to provide adequate protection to unit(s) while not interfering with other construction operations.
- C. Handle ductless split AC system (s) carefully to avoid damage to components, enclosures, and finish. Do not install damaged equipment; replace and return damaged components to equipment manufacturer.

1.8 **WARRANTY**

1. The warranty period shall commence on the date that the Owner accepts the completed building.
2. The contractor shall provide a warranty for a period one (1) year and include all parts and labor for the full extended guarantee period.
3. The manufacturer shall provide a parts and defects warranty for a period five (5) years and the compressor shall have a warranty of seven (7) years. If, during this period, any part should fail to function properly due to defects in workmanship or material, it shall be replaced or repaired at the discretion of the manufacturer. This warranty does not include labor.

PART 2 - PRODUCTS

2.1 **MANUFACTURED UNITS**

- A. **Description:** Ductless split system, single zone, cooling only, utilizing a scroll type compressor controlled by a variable speed inverter drive.
- B. **Performance Rating:** Cooling capacity of units shall meet the sensible heat and total heat requirements determined per design calculations and stated on the design drawings. In selecting unit size, make true allowance for "sensible to total heat ratio" to satisfy the sensible cooling capacity.

2.2 **COMPONENTS**

- A. Air Handling Unit (AHU)

1. High performance indoor wall mounted ductless AHU, with straight cool and no electric heat. The air handling units shall be factory assembled, wired, and tested. Ensure the AHU's are equipped with a self-diagnostic feature, a 3-minute time delay mechanism, an automatic restart function after a power failure, and a test run switch.
2. Fan: Direct drive sirocco fan with double inlet, forward curve, operated by a single motor. The fan shall be statically and dynamically balanced and the fan motor will be equipped with permanently lubricated bearings. The indoor fan shall have three different fixed speed settings: Low, Mid, Hi, and an Auto speed setting. The Auto fan setting will adjust the fan speed based on the difference between controller set-point and room temperature.
3. Vanes: There shall be a motorized horizontal vane to automatically direct air flow in a horizontal and downward direction for uniform air distribution. The horizontal vane shall significantly decrease downward air resistance for lower sound levels, and shall close the outlet port when operation is stopped. There shall also be a set of vertical vanes to provide horizontal swing airflow movement.
4. Each AHU will be factory configured for left hand or right hand piping connections that is field selected by the installer.
5. The long life return air filter shall be washable.
6. A factory provided wall installation bracket shall be shipped with each unit.
7. The evaporator coil shall be of nonferrous construction with pre-coated aluminum strake fins on copper tubing. The multi-angled heat exchanger shall have a modified fin shape that reduces air resistance for a smoother, quieter airflow. All tube joints shall be brazed with PhosCopper or silver alloy. The coils shall be pressure tested at the factory.
8. A condensate pan with a drain shall be factory provided under the evaporator coil. A condensate pan liquid level switch (DPLS1) will connect to the unit control board, and if actuated will stop the AHU from running to prevent condensate from overflowing.
9. The indoor air handler unit shall receive operating power from the outdoor condensing unit.

C. Refrigeration System

1. The refrigeration system shall include a liquid line filter drier, a linear expansion valve and a high-pressure safety switch. Refrigeration system's will use R-410A. Refrigerant lines between outdoor and indoor units shall be of annealed, refrigeration grade copper tubing, ARC Type, meeting ASTM B280 requirements. Ensure the refrigerant lines are individually insulated in twin-tube, flexible, closed-cell, CFC-free, elastomeric material.

D. Heat Pump Unit (HP)

1. Compressor: automatically vary to match the room heat load.
 - a. The compressor shall be a DC twin-rotor rotary compressor with Variable Speed Inverter Drive Technology.
 - b. The compressor shall be driven by inverter circuit to control compressor speed. The compressor speed shall dynamically vary to match the room load for significantly increasing the efficiency of the system which shall result in significant energy savings.

- c. To prevent liquid from accumulating in the compressor during the off cycle, a minimal amount of current shall be automatically, intermittently applied to the compressor motor windings to maintain sufficient heat to vaporize any refrigerant. No crankcase heater is to be used.
- d. The outdoor unit shall have an accumulator and high pressure safety switch. The compressor shall be mounted to avoid the transmission of vibration.

2. Provide each HP with the factory Seacoast Protection package that consists of:

- a. External Outer Panel: Phosphate coating + Acrylic-Enamel coating.
 - b. The fan motor support: Epoxy resin coating (at edge face).
 - c. Separator Assembly; Valve Bed: Epoxy resin coating (at edge face).
 - d. Blue Fin protective treatment: This treatment is an anti-corrosion treatment that is applied to the condenser coil to protect it against airborne contaminants.
- E. The air cooled heat pump/condenser shall be constructed of mechanically expanded copper tubes in enhanced surface aluminum fins. Components shall be rated for up to 100-degrees F ambient.
- F. The outdoor unit shall be controlled by the microprocessor located in the indoor unit. The control signal between the indoor unit and the outdoor unit shall be pulse amplitude modulated signal, 24 volts DC.
- G. Sequence of Operation: Refer to mechanical plans for the Dual HVAC Control System and Sequence of Operation.

2.3 CONTROL SYSTEM

- A. The Lead/Lag dual unit control system & thermostat shall consist of sensors, indicators, final control elements, interface equipment, other apparatus, and accessories to control mechanical systems such that the programmed temperature is maintained within the building.
- B. The control system shall include a solid state microprocessor based dual unit Lead/Lag controller designed to operate redundant air conditioning systems with the following requirements:
 - 1. Factory programmed with capability to field reprogram set points per Owner's preferences.
 - 2. Lead/Lag controller to be programmed to operate both AC units to insure equal wear on both units while allowing the Lag unit to assist upon demand.
 - 3. Program settings should be retained during indefinite power loss to the controller.
 - 4. Lag unit automatically becomes Lead unit if lead unit loses power.

PART 3 - EXECUTION

3.1 INSPECTION

- A. Examine rough-in electrical services and installation of floors and walls and other conditions under which ductless split units are to be installed. Verify dimensions of services and substrates before installing units.

3.2 INSTALLATION

- A. Set each ductless split component securely in place, in strict accordance with manufacturer's instructions; adjust to correct height and level.
- B. Provide adequate drainage for condensate system.

3.3 CLEANING

- A. After completion of installation and completion of other work in surrounding areas, remove protective coverings, if any, and clean ductless split systems, internally and externally.

3.4 EXTRA PARTS

- A. Provide one additional/spare filter for each unit.

3.5 PAYMENT

- A. The lump sum price for Building Complete covers all items of work in this Special Provision including furnishing labor, materials, tools, equipment, and incidentals required to complete the work.

END OF SECTION

State Road and Tollway Authority (SRTA), State of Georgia

SPECIAL PROVISION

Section 670 – Water Distribution System

670.1 General Description

This work includes furnishing materials for installing, relocating, and adjusting water distribution systems according to the Plans and Specifications.

670.1.1 Definitions

General Provisions 101 through 150.

670.1.2 Related References

A. Standard Specifications

Section 104—Scope of Work

Section 107—Legal Regulations and Responsibility to the Public

Section 207—Excavation and Backfill for Minor Structures Section 444—Sawed Joints in Existing Pavements

Section 500—Concrete Structures Section 555 Tunnel Liner

Section 611—Relaying, Reconstructing or Adjusting to Grade of Miscellaneous Roadway Structures

Section 615—Jacking or Boring Pipe

Section 810—Roadway Materials Section 841—Iron Pipe

Section 847—Miscellaneous Pipe Section 848—Pipe Appurtenances

B. Related Documents

General Provisions 101 through 150.

670.1.3 Submittals

General Provisions 101 through 150.

670.2 Materials

A. Cast Iron and Ductile Iron Pipe

See Section 841. Use pipes with mechanical or push-on joints. If the Plans or the Engineer allow, use bell and spigot pipe with lead joints.

Ensure that pipes are the class called for on the Plans.

B. Cast Iron Fittings

See Section 841. Fittings consist of cast iron bends, tees, crosses, plugs and reducers, double hub tapped tees, offsets, sleeves, plugs, and other cast iron specials necessary to the work.

Ensure that the class of each fitting is at least the class of pipe to which it is connected. Use fittings furnished with the following:

- The manufacturer's center-to-center and center-to-socket laying dimensions

- The manufacturer's standardized mechanical joints or bell and spigot with lead and rubber joints

C. Gate Valves

See Section 848.2.03. Use gate valves that function as follows:

1. Open to the left, unless otherwise specified
2. Are operated by nut
3. Use operating nuts similar to those used by the local water works system, with an arrow indicating the valve opening direction
4. Are designed for vertical installation with nonrising stems and operating nuts, except as follows:
 - Valves 16 in (400 mm) and larger are designed for horizontal installation with bevel gears, an extended gear case with protectors, track, trunnions, scrapers, and a by-pass.
5. Include mechanical joints, bolts, glands, and gaskets unless otherwise indicated on the drawings or necessary to join existing work
6. Include split sleeve mechanical joint-type tapping sleeves
7. Include mechanical joint hub connections
8. Include valve boxes designed as follows:
 - Made for heavy roadway use
 - Made with cast-iron and two-piece slip or screw
 - Made with round drop covers adjustable up or down to 6 in (150 mm)
 - Made with the proper depth, including extensions, unless otherwise specified

D. Butterfly Valves

Use butterfly valves in water mains 12 in (300 mm) and larger. Ensure that butterfly valves meet these requirements:

- Consist of either a cast iron valve body for buried service or a stainless steel-to-rubber seated tight closing body suitable for two-way flow, Class 150 B
- Contain manual operators sized for line pressure and velocities
- Contain 2 in (50 mm) square operating nuts and extension stems and guides, as required
- Open counterclockwise (to the left)
- Contain mechanical joints suitable for pipeline connections
- Comply with AWWA C-504

E. Service Line Pipes, Fittings, and Appurtenances

Use fittings and appurtenances for pipe, as follows:

1. Fittings

Use the following fittings for copper, galvanized steel, and plastic pipe:

- a. Copper Pipe (or Tubing)
 - Use cast or wrought pattern copper fittings.
 - Use solder joint fittings for rigid copper pipe.
 - Use flared mechanical fittings, if desired, for concealed soft drawn pipe.
 - Use ground joint unions.
 - See Subsection 847.2.03.
- b. Galvanized Steel Pipe
See

Subsection

847.2.01.

c. **Plastic Pipe**

See Subsection 847.2.05.

2. **Appurtenances**

Corporation stops, curb stops, or other appurtenances may be substituted for an adapter if its connections are designed for the appurtenances. Meet the following requirements:

- a. Ensure that corporation stops, curb stops, and other appurtenances for copper, galvanized iron, or plastic pipe service lines meet the requirements of ASTM B 62 and AWWA C 800 for threads.
- b. Use adapters to joint plastic, copper, or galvanized iron pipe to existing facilities.
- c. Use a cut-off key that conforms closely to the type used by the water system that the work is connecting to.

F. **Polyvinyl Chloride (PVC) Pipe**

See Subsection 847.2.05.A.1.

Use pipes that are furnished with either solvent cement or elastomeric gasket coupling.

G. **Steel Pipe Casing**

For welding use plain-end casings the size, thickness, length, and coating specified on the Plans.

H. **Double Strap Saddles**

Ensure that double strap saddles conform to Plan details, or are as directed by the Engineer.

I. **Fire Hydrants**

Use fire hydrants that meet the latest AWWA Specifications and local code requirements. In addition, fire hydrants shall meet the following parameters:

1. **Compressive, Self-Oiling, and Nonfreezing Use**
hydrants sealed and lubricated as follows:
 - a. The operating nut is totally sealed away from the hydrant barrel.
 - b. A large oil reservoir and packing gland continuously and automatically lubricates working parts.
 - c. The drain mechanism operates simply, positively, and automatically.
2. **Hydrant Safety Flange and Coupling**
Construct the safety flange and coupling above the ground line to permit rapid replacement. Ensure that the force of impact in a traffic accident will break the flange and spread the valve stem coupling.
3. **Nozzle Direction**
Construct the hydrant's nozzles to face in any direction at any time by removing the safety flange bolts and revolving the head without digging or cutting off water.
4. **Accessibility to Internal Parts**
Ensure that all working parts of the hydrant, including the seat ring, can be removed through the top without digging. Confirm that seat rings are:
 - Made of bronze
 - Shaped and arranged to be readily removable

- Able to be screwed into a bronze bushing in the shoe
5. **Cover Depth**
If needed, supplement the Department-provided 3-1/2 ft (1 m) vertical leader pipe with extension sections at no additional cost.
 6. **Valve Opening**
Ensure that valve openings are at least 4-1/4 in (106 mm).
 7. **Hose and Steamer Connection**
Breech-lock the hose and steamer connections into the hydrant barrel, then caulk with lead to seal them permanently, or thread and pin them into the hydrant body. Hydrants include two 2-1/2 in (63 mm) hose nozzles and one steamer connection.
 8. **Threads**
Use "National Standard" threads for hose nozzles and steamer connections, unless otherwise specified.
 9. **Operating Nut**
Unless otherwise specified, use 5-sided operating nuts with 1 in (25 mm) flat surfaces.
 10. **Inlet Connection**
Use 6 in (300 mm) inlet connections furnished with mechanical joints to connect to the mechanical joint lead spigot.
- J. **Concrete Blocking**
Use "Class A" concrete for fire hydrant blocking constructed according to Section 500.

670.2.01 Delivery, Storage, and Handling

Carefully handle pipe, fittings, and other materials to avoid breaking or damaging the cement mortar linings.

Do not roll or drop pipe off trucks or cars. To unload pipe, carefully lift and lower it into position using approved slings and clamps.

670.3 Construction Requirements

670.3.1 Personnel

General Provisions 101 through 150.

670.3.2 Equipment

A. Valve-Tapping Machine

Furnish the valve-tapping machine and all other equipment required for each installation.

B. Test Pump and Pressure Measurement

Use a high-quality, reliable test pump and a means of accurately measuring the water required to maintain pressure during the prescribed testing time.

C. Underground Pipe and Cable Finder

Use a high-quality electronic pipe and cable finder to accurately locate underground utilities and other installations to the Engineer's satisfaction.

670.3.3 Preparation

General Provisions 101 through 150.

670.3.4 Fabrication

General Provisions 101 through 150.

670.3.5 Construction

A. Finding Existing Underground Utilities and Obstructions

Comply with Subsection 107.13 and Subsection 107.21.

According to the best information available to the Department, all known water lines, gas lines, telephone conduits, drainage structures, etc., are shown on the Plans. However, to find such installations, use an electronic pipe and cable finder and assist the Engineer in locating existing installations or obstructions to the work.

When unforeseen conflicts require Plan changes, perform the work as altered according to Subsection 104.03 and Subsection 104.04.

B. Excavating Trenches

Excavate trenches to the proper grade, depth, and width as follows:

1. Trench to Grade

Ensure that excavated trench bottoms are firm, free from boulders, and conform to the established grade.

- a. **Backfill**, according to Subsection 670.3.05.E.6, any part of the trench excavated below the established grade. Use Class I or Class II Soils (Section 810), and firmly compact the soil.
- b. Where the established grade of a trench is in rock, undercut the bottom of the trench by at least 6 in (150 mm), then backfill and compact according to Subsection 670.3.05.E.6. Conduct blasting operations strictly according to Subsection 107.12.
- c. **Excavate trenches under pavement to grade as follows:**
 - 1) To remove the pavement, cut it at least 24 in (600 mm) wider than each trench edge to provide solid bearing for the pavement edges when replaced. Remove the pavement according to Section 444, except no separate payment will be made for sawed joints unless a bid item is contained in the Proposal.
 - 2) Tunnel under existing sidewalks, curbs, gutters, and pavements according to Section 555.
 - 3) Where possible, jack pipe under an existing pavement according to Section 615, except no separate payment will be made for jacking and boring pipe unless a bid item is included in the Proposal.

2. Minimum Trench Depth

Excavate trenches to provide at least 48 in (1.2 m) cover depth from the pipe to the finished pavement surface, sidewalk, grass plot, etc. unless indicated otherwise on the Plans or by the Engineer.

If any part of a water main is to be placed in or under a new embankment, finish the embankment to at least a 2 ft (600 mm) plane above the pipe barrel before excavating the trench.

3. Trench Width

Excavate trenches wide enough to allow proper installation of pipe, fittings, and other materials.

4. Trench Bellholes

Excavate bell holes deeply and widely enough to make joints and to allow the pipe barrel to rest firmly on the ditch bottom.

C. Connecting to Existing Mains

Connect to an existing main with the appropriate fittings according to the Plans or the Engineer. When making connections under pressure, i.e., when normal water service must be maintained, furnish and use a tapping sleeve and valve. Connect to existing mains as follows:

1. Before opening new pipe line trenches, locate the various points of connections to be made into existing pipe lines. If necessary, uncover pipe lines for the Engineer to prescribe the connections and fittings needed.

2. Connect to existing pipe lines only to meet operating requirements. Cut existing lines only after obtaining the Engineer's permission.

D. Laying Water Mains and Appurtenances

Lay mains, fittings, and appurtenances as follows:

1. Preparing and Handling Pipes

Thoroughly clean the pipe and fittings before laying them. Keep them clean until accepted.

Use suitable tools and equipment. Do not damage the pipe, especially the cement lining inside the cast iron pipe.

Carefully examine pipe for cracks and other defects and do not lay defective pipe. If pipe or castings appear to be cracked, broken, or defective after laying, remove and replace those sections.

2. Alignment and Gradient

Ensure that pipe line alignment and gradient are either straight or deflected to closely follow true curves. Deflect pipe lines only where required, within allowable horizontal and vertical deflection angles according to the Plans.

3. Special Requirements for Laying Water Mains

Excavate, clean, lay, joint, and backfill progressively and uniformly according to these requirements:

- Never leave pipe in the trench overnight without completely jointing and capping.
- Do not leave completed pipe line exposed in the trench. Backfill and compact the trench as soon as possible after laying, jointing, and testing are complete.
- At the close of work each day, and when laying pipe, close the exposed end of the pipe-line in the trench with an approved wood or metal head or barrier.
- If necessary to cover the end of an incomplete pipe line with backfill, close the end of the pipe with a satisfactory cap or plug.

E. Installing Water Mains

Install water mains as follows:

1. Flexible Joints

Use the following flexible joints for connections inside the roadway shoulders or curbs and gutters:

a. Mechanical Joints

When using mechanical joints:

- 1) Thoroughly wash bell sockets, spigots, gland, gasket, nuts, and bolts with soapy water before assembly. Keep these parts wet until the jointing operation is complete.
- 2) Tighten nuts within the torque range recommended by the manufacturer. Check the tightening tolerance with a torque wrench.
- 3) If effective sealing is not attained at the maximum recommended torque, disassemble, thoroughly clean, then reassemble the joint.
- 4) Do not overstress bolts to compensate for improper installation or defective parts.

b. "Push-On" Type Joints

Use "push-on" joints made according to the manufacturer's recommendations.

c. Bell and Spigot Connections with Lead Joints

Thoroughly clean the bell inside and the pipe outside. Join bell and spigot connections with lead and gasket as follows:

- 1) Gasket: Use a tubular or molded rubber gasket installed according to the manufacturer's

recommendations.

Use asbestos rope or treated paper rope only with the Engineer's approval when the space between the bell and spigot will not permit the use of a rubber ring.

- 2) **Lead:** Place the lead joint at least 2 in (50 mm) deep and pour it to the full depth of the lead groove.
 - Keep the melting pot near the joint being poured. Make only one pouring for each joint.
 - Do not allow dross to accumulate in the melting pot.
 - Thoroughly caulk the joints to secure a tight joint without overstraining the iron in the bells.

2. Cutting Pipe for Water Mains

Use pipe cutters when cutting pipe or special castings. Do not use a hammer and chisel or a cutting torch.

3. Gate Valves on Water Mains

Install and joint gate valves as specified in Subsection 670.2.C. Include the valve box, where required.

4. Fire Hydrants

Install and joint hydrants as specified in Subsection 670.2.I. Include required vertical extension sections. Also, include pipe strap installation, concrete blocking, crushed stone drain, and backfill according to the Plans and this Section.

5. Concrete Blocking

Furnish materials and install concrete blocking according to Subsection 670.2.J. Form and pour concrete blocking at the backs of fittings, including elbows, tees, pipe plugs, fire hydrants, and other locations according to the Plans or the Engineer.

6. Backfilling

Furnish equipment, labor, and when necessary material required for backfilling the pipe line trenches according to Section 207.

- a. When testing for leaks in open trenches, do not backfill until testing is complete and leaks are eliminated.
- b. When retaining pavement adjacent to trenches, replace removed pavement with the same or better material when approved.
- c. After backfilling, maintain a smooth riding surface until the repaving is complete. No separate payment will be made for replaced pavement unless a bid item for this work is contained in the Proposal.

7. Sterilizing Water Mains

Before placing new and existing pipe lines and appurtenances in service, sterilize them within the overall construction limits. Sterilize in conjunction with the pressure test, if desired.

a. Chlorination

Sterilize using only potable water with calcium hypochlorite (HTH), one percent chlorine solution, or other products acceptable to the Engineer and Department of Public Health.

- 1) Add enough sterilizing agent to provide a chlorine residual of 10 ppm (parts per million) in 24 hours.
- 2) At the end of 24 hours, check the chlorine residual. If it is less than 10 ppm, add additional chlorine and check the line again after 24 hours.

b. Flushing

After sterilization, flush the line with potable water until the chlorine residual in tests made at the point of discharge is equal to the chlorine residual of the potable water used for flushing.

c. Sampling

Take all samples in the presence of the Engineer.

- 1) Leave the pipe line full for 24 hours and request the local Health Department to take bacteriological samples to the Georgia Department of Public Health for analysis.
- 2) When test results are not satisfactory, sterilize again, without additional compensation, until satisfactory samples are obtained.

F. Laying Service Lines and Appurtenances

Except as modified in this Section, construct and install service lines according to the requirements for laying water mains.

Install service lines at locations shown on the Plans or where designated by the Engineer. Install new pipe from the water main to the final location of the meter or to points designated by the Engineer to connect with existing or future service lines on abutting property.

A complete service line pipe installation includes all connections using unions, valves, fittings, corporation stops, goosenecks where permitted, and curb stops.

1. Excavation for Service Lines

Excavate as previously specified in Subsection 670.3.05.B, with the following exceptions:

- Ensure that trenches under pavements and across driveways are deep enough to provide at least 48 in (1.2 m) of cover, unless otherwise directed by the Engineer.
- At other areas, trench depth and backfill cover may be adjusted at the discretion of the Engineer to provide at least 18 in (450 mm) of cover.

2. Backfill for Service Lines

Backfill as specified in Subsection 670.3.05.E.6 for water mains, with the following exception:

- Backfill only after a leakage test has been made under normal operating pressure in open trenches and all leaks have been eliminated.

3. Laying and Jointing Service Lines

Install copper, galvanized steel, and plastic service lines as follows:

a. Copper Pipe

- 1) Cut square and burr internal and external pipe ends before inserting them in fitting sockets.
- 2) Sand pipe ends clean and wire-brush fitting sockets clean to ensure 100 percent tinning of the socket and pipe joint surfaces and full solder penetration of the joint. Do not use acid or acid-based material for surface cleaning.
- 3) While the solder is still molten, wipe the solder bead at the external joint with a dry cloth.

b. Galvanized Steel Pipe

Install galvanized steel pipe according to the applicable trenching and laying specifications for other service lines, as they apply. (See Subsection 670.2.E.1.b.)

c. Plastic Pipe

Install plastic service line pipe according to the manufacturer's recommendations. Use compression or flare connections.

- 1) Snake plastic pipe in the trench, allowing at least one percent additional pipe length for thermal contraction.
- 2) Before backfilling, run water through the pipe to cool to operating temperature. Under normal line operating pressure, check all joints for leaks.
- 3) After repairing leaks, backfill the trench with 6 in (150 mm) of clod- and rock-free material. Thoroughly tamp before proceeding with normal backfill.

G. Relocating, Adjusting, and Removing

1. Fire Hydrants and Water Valves

Relocate, adjust to grade, or remove fire hydrants and water valves and valve boxes according to the Plans or as designated by the Engineer.

- a. Protect parts during removal and relocation. Replace lost or damaged Items at no expense to the Department.
- b. Melt out lead or composition joints. Disconnect each joint before removing them from the trench.
- c. Install relocated gate valves or fire hydrants as specified for new gate valves or fire hydrants.
- d. Construct concrete blocking as specified above for fire hydrants (see Subsection 670.2.I).
- e. Remake tests for leakage and retest until no leaks appear.
- f. Backfill as specified in Subsection 670.3.05.E.6.
- g. Consider valve boxes part of the valve assembly and remove them intact with the valve.

Concrete blocking and additional pipe required to reset the gate valve or fire hydrant at its new location will be paid for separately.

2. Existing Water Meters and Boxes

Relocate these according to the Plans or the Engineer.

- a. To relocate water meters, remove the existing meter and box and install a short section of pipe in their place.
- b. Inspect, along with the Engineer, each meter before its removal to determine the meter's condition. The Department will replace defective meters.

This Item also includes, without additional compensation, required pipe, unions and appurtenances, necessary storage protection, and reinstallation of the meter, meter box, and curb stop in the existing service line, as directed.

3. Existing Water Service Lines

Water lines will be adjusted to grade by excavating the existing lines, lowering or raising the lines, and backfilling according to the Plans or the Engineer.

- a. Furnish new materials or fittings required for the adjustment without additional compensation.
- b. Change connections at the main that result from this work.
- c. Repair leaks and damage caused by the operations at no expense to the Department.
- d. When retaining a water meter where an existing service line is to be adjusted, adjust the existing meter and box to the proper grade without additional compensation.

4. Existing Water Meter and Water Valve Boxes

Lower or raise these to the grade established on the Plans or by the Engineer according to Section 611.

670.3.6 Quality Acceptance

A. Testing Water Mains

When the Engineer approves a section of pipe for testing, furnish the materials, equipment, and labor to conduct the test. Use a test pump and a means of measuring the water necessary to maintain the required pressure during the prescribed testing time.

Furnish, install, and remove temporary bulkheads, flanges, plugs, and corporation stops at high points in the pipe line and at the test pump, when necessary.

Use the following testing sequence:

1. Preparation

Whenever the Engineer determines, test pipe lines before backfilling the trench and service installing lines. However, if high-pressure testing after service lines are in place, shut the lines off at the corporation stops.

After installing necessary joints, bulkheads, etc., place corporation stops, if no other means can be provided, in the high points of the pipe line and at the pump. Blow the pipe free of air according to accepted procedure.

2. Testing Requirements

Follow these requirements when testing:

- Ensure that the test pressure is 50 lbs/in² (345 kPa) higher than the designated class pressure of pipe and fittings.
- Ensure that leakage does not exceed 15 gal/in of pipe diameter/ mile (1.4 L of pipe diameter/km) per 24 hours.
- Test the pipe line for two hours.
- If the Engineer determines that additional testing is required, perform the procedure with no additional compensation.
- When service lines cannot be isolated (i.e., shut off from the section to be tested), or where pressure testing as described above may cause damage, test the line under normal operating pressure as approved by the Engineer.

Where possible, do this work in open trenches. Replace cracked, broken, or defective materials and carefully remake joints that leak.

B. Retesting

After the Engineer feels the above conditions have been corrected, retest the lines until they pass the necessary requirements. No additional compensation will be made for the corrections or retesting.

670.3.7 Contractor Warranty and Maintenance

General Provisions 101 through 150.

670.4 Measurement

Water mains, service lines, and other items of work in this Specification, complete, in place, and accepted, are measured for payment as follows:

A. Water Mains

Water mains are measured in linear feet (meter) for each size installed. The mains are measured along the center, parallel to the slope of the pipe, from end of each installation through all valves and fittings.

B. Fittings

Pipe fittings are considered subsidiary to the water line in which they are used and are not measured for separate payment.

C. Gate Valves Including Boxes

When required, these are measured by the number of each size installed.

D. Tapping Sleeve and Valve Assembly

These are measured by the number of each size installed.

E. Fire Hydrants

These are measured by the number of each installed.

F. Service Lines

Service lines are measured in linear feet (meter) for each size of service pipe installed. Measurements are made from end to end and from center of lines to ends of branches including valves and fittings. Valves and fittings are not measured separately for payment.

G. Existing Fire Hydrants, Water Valves, and Water Meters Relocated

Existing fire hydrants, water valves, and water meters are measured by the number of each actually relocated, including relocation and final adjustment of boxes.

H. Existing Meter Boxes and Valve Boxes Adjusted to Grade

Existing meter boxes and valve boxes, adjusted to grade in their original locations, are measured by the number adjusted according to Section 611.

I. Water Valves and Fire Hydrants Removed

Existing water valves, including boxes when necessary, and fire hydrants are measured by the number of each removed.

J. Excavation for Trenches

Excavation is not measured for payment separately, but its cost is included in the amount bid for the Item to which it pertains.

K. Concrete Blocking

The quantity of concrete blocking installed according to and within the limits of Plan details, or as specified, is measured in cubic feet (meters).

L. Service Lines Adjusted to Grade

This Item is measured in linear feet (meters) of service line pipe lowered or raised, including valves, fittings, meters, boxes, and other integral appurtenances. Measurements are made from end to end of actual adjustments.

M. Incidentals

Backfilling, pavement removed, and pavement replaced, including sawing, testing, and sterilizing, are not measured for separate payment.

N. Steel Casing

This is measured in linear feet (meters) for each size installed. Measurements are made along the center, parallel to the slope of the casing.

O. Butterfly Valves Including Boxes

When required, these are measured by the number of each installed.

P. Double Strap Saddles

These are measured by the number of each size installed.

670.4.01 Limits

General Provisions 101 through 150.

670.5 Payment

The Contract Unit Price for each Item, complete and accepted, will include all costs incidental to the construction of the Item according to the Plans and as specified in this Section.

The Unit Prices bid will include due allowance for the salvage value of all materials removed from existing or temporary lines, and not installed in the completed work. All such surplus items will become the property of the Contractor unless otherwise specified.

Payment for any Item listed below is full compensation for the Item or Items, complete in place. When placing water mains or service lines in casings, receive separate payment for the cost of furnishing and installing the casings.

A. Water Main Pipe

These will be paid for at the Contract Unit Price per linear foot (meter) for each size of pipe installed. Payment is full compensation for furnishing all materials including fittings, excavating, backfilling, removing, and replacing pavement, testing and sterilizing, and providing other

incidentals necessary to complete the Item. Payment will also include the cost of laying pipe in casing when required.

B. Gate Valves

These will be paid for at the Contract Unit Price per each for each size of valve installed, complete in place, including the box, if required. Payment will include material and labor for joint connections.

C. Tapping Sleeve and Valve Assemblies

These will be paid for at the Contract Unit Price per each size installed, complete in place, including materials and labor for joint connections.

D. Fire Hydrants

These will be paid for at the Contract Unit Price per each hydrant installed, complete in place, including vertical extensions, joint connections, pipe straps, crushed stone drain, and other incidentals necessary to complete the Item.

E. Service Line Pipe

This will be paid for at the Contract Unit Price per linear foot (meter) for each size of pipe or tubing. Payment is full compensation for excavating, backfilling, removing, and replacing pavement, testing and sterilizing, placing corporation and curb stops and goosenecks, where required, placing fittings, jointing, and connecting to the main, and providing other incidentals necessary to complete the Item. Payment will also include laying pipe in casing when required.

F. Relocation of Existing Fire Hydrant

This will be paid for at the Contract Unit Price per each, complete in place, including crushed stone drain and other incidentals necessary to complete the Item.

G. Relocation of Existing Water Valve, Including Box

This will be paid for at the Contract Unit Price per each set, complete in place, including excavation, backfill, and other incidentals necessary to complete the Item.

H. Relocation of Existing Water Meter, Including Box

This will be paid for at the Contract Unit Price per each set, complete in place, including excavation, backfill, and other incidentals necessary to complete the Item.

I. Adjusting Existing Meter Boxes and Valve Boxes

These will be paid for according to Section 611.

J. Removal of Existing Water Valves to Grade

This will be paid for at the Contract Unit Price per each water valve removed. Valve boxes, when existing, will be included and removed without additional compensation.

K. Removal of Existing Fire Hydrants

This will be paid for at the Contract Unit Price per each fire hydrant removed.

L. Excavation for Trenches

No separate payment will be made for excavation.

M. Concrete Blocking

This will be paid for at the Contract Unit Price per cubic yard (meter), complete in place. Payment will include excavating, backfilling, forming, and performing necessary Work incidental to placing concrete blocking according to the Plans, or as specified. Payment will be made under Section 500.

N. Steel Casing

This will be paid for at the Contract Unit Price per linear foot (meter) for each size of casing installed. Payment is full compensation for furnishing all materials, excavating, backfilling, removing, and replacing pavement, and providing other incidentals necessary to complete the item.

O. Butterfly Valves

These will be paid for at the Contract Unit Price per each size of valve installed, complete in place, including the box, if required. Installation includes materials and labor for joint connections.

P. Double Strap Saddles

These will be paid for at the Contract Unit Price per each size installed complete in place, including materials and labor for joint connections.

Payment will be made under:

Item No. 670	Water main__in (mm)	Per linear foot (meter)
Item No. 670	Gate valve_ __ in (mm)	Per each
Item No. 670	Tapping sleeve and valve assembly __ in (mm) x_	Per each
Item No. 670	Fire hydrant	Per each
Item No. 670	Water service line__in (mm)	Per linear foot (meter)
Item No. 670	Relocate existing fire hydrant	Per each
Item No. 670	Relocate existing water valve including box	Per each
Item No. 670	Relocate existing water meter including box	Per each
Item No. 670	Adjust water service line to grade	Per linear foot (meter)
Item No. 670	Remove existing water valve including box	Per each
Item No. 670	Remove existing fire hydrant	Per each
Item No. 670	Steel casing __ in (mm)	Per linear foot (meter)
Item No. 670	Butterfly valve__in (mm)	Per each
Item No. 670	Double strap saddle_ __ in (mm) x_____ in (mm)	Per each

670.5.01 Adjustments

General Provisions 101 through 150.

END OF SECTION

State Road and Tollway Authority (SRTA), State of Georgia

SPECIAL PROVISION

Section 999 – Detention Pond – Underground

Underground Detention System

PART 1 - GENERAL

1.1 SUBMITTALS

A. Shop Drawings:

1. **Underground Pipe Detention System:** Include plans, elevations, sections, details, frames, and covers, signed and sealed by a Georgia Registered Professional Engineer.
2. **On-line media filters:** Include plans, product data, and specifications (for specified insert).
3. **Water quality treatment device:** Include plans, product data, and specifications for the hydrodynamic separator.

1.2 DELIVERY, STORAGE, AND HANDLING

- ###### A. Handle underground detention system components according to manufacturer's written rigging instructions.

PART 2 - PRODUCTS

2.1 STORMWATER DETENTION STRUCTURES

- ###### A. Stormwater Detention System: Constructed of 84-in diameter corrugated metal pipe; at a minimum should be designed according to ASTM C 890 for A-16 (AASHTO HS20-44), heavy-traffic, structural loading; of depth, shape, dimensions, and appurtenances indicated.

1. **Corrugated Metal Pipe:** 84-in. diameter, 12-gauge (must be properly designed, gauge may be adjusted as needed), Aluminized Type 2 coating, perforated wall in accordance with AASHTO and ASTM specifications, with Huggar Style Bands and a 7-in wide, 3/8-in thick Flat Gasket.
2. **Structural Backfill:** Stone backfill in accordance with manufacturer's written specifications.
3. **Storage Volume:** Minimum 119,400 of total storage volume
4. **Manway/Riser:** Provide as shown on plan(s) and in accordance with manufacturer's recommendations.

- ###### B. On-line media filters: Provide on-line media filters at all inlets that are above and discharge directly into the underground detention system. The media filters must be designed to remove sediment, solids, trash, and petroleum hydrocarbons from stormwater runoff. The filter flow

capacities should be designed to meet or exceed the required "first-flush" treatment flow rate and provide adequate bypass capacity for flows that exceed capacity.

- C. **Water quality treatment device:** Provide a hydrodynamic separator to screen, separate and trap debris, sediment, and hydrocarbons from the stormwater runoff. The unit must be sized to either achieve an 80 percent average annual reduction in the total suspended solid load or treat a flow rate designated by the jurisdiction in which the project is located. Both methods should be sized using a particle size distribution having a mean particle size (d50) of 125 microns unless otherwise stated. The unit shall be capable of capturing and retaining 100 percent of pollutants greater than or equal to 2.4 millimeters (mm) regardless of the pollutant's specific gravity for flows up to the device's rated-treatment capacity.
1. Housing unit of stormwater treatment device shall be constructed of pre-cast or cast-in-place concrete, no exceptions. Precast concrete components shall conform to applicable sections of ASTM C 478, ASTM C 857 and ASTM C 858 and the following:
 - a. Concrete shall achieve a minimum 28-day compressive strength of 4,000 pounds per square-inch (psi);
 - b. Unless otherwise noted, the precast concrete sections shall be designed to withstand lateral earth and AASHTO H-20 traffic loads;
 - c. Cement shall be Type III Portland Cement conforming to ASTM C 150;
 - d. Aggregates shall conform to ASTM C 33;
 - e. Reinforcing steel shall be deformed billet-steel bars, welded steel wire or deformed welded steel wire conforming to ASTM A 615, A 185, or A 497.
 - f. Joints shall be sealed with preformed joint sealing compound conforming to ASTM C 990.
 - g. Shipping of components shall not be initiated until a minimum compressive strength of 4,000 psi is attained or five (5) calendar days after fabrication has expired, whichever occurs first.
 2. Internal Components and appurtenances shall conform to the following:
 - a. Screen and support structure shall be manufactured of Type 316 and 316L stainless steel conforming to ASTM F 1267-01;
 - b. Hardware shall be manufactured of Type 316 stainless steel conforming to ASTM A 320;
 - c. Fiberglass components shall conform to the ASTM D-4097
 - d. Access system(s) conform to the following:
 - e. Manhole castings shall be designed to withstand AASHTO H-20 loadings and manufactured of cast-iron conforming to ASTM A 48 Class 30.

PART 3 - EXECUTION

3.1 STORMWATER DETENTION SYSTEM INSTALLATION

- A. **Piping Systems:** Excavate trenches of width and depth, and install piping system, filter fabric, and backfill, according to piping manufacturer's written instructions.

3.2 FIELD QUALITY CONTROL

- A. Inspect interior of piping to determine whether line displacement or other damage has occurred. Inspect after approximately 24 inches of backfill is in place, and again at completion of Project.

1. Submit separate reports for each system inspection.

2. **Defects requiring correction include the following:**
 - a. **Alignment:** Less than full diameter of inside of pipe is visible between structures.
 - b. **Deflection:** Flexible piping with deflection that prevents passage of ball or cylinder of size not less than 92.5 percent of piping diameter.
 - c. **Damage:** Crushed, broken, cracked, or otherwise damaged piping.
 - d. **Infiltration:** Water leakage into piping at pipe joints.
 - e. **Exfiltration:** Water leakage from or around piping at pipe joints.
3. **Replace defective piping using new materials and repeat inspections until defects are within allowances specified.**
4. **Reinspect and repeat procedure until results are satisfactory.**

3.3 CLEANING

- A. **Clean interior of piping of dirt and superfluous materials. Flush with potable water.**

3.4 PAYMENT

- A. **Payment for the underground detention system shall be lump sum and shall include all items such as piping materials, connections, structures, stone backfill, filter fabric, etc.**
- B. **Payment for the on-line media filters shall be lump sum and included with the underground detention system.**
- C. **Payment for the water quality treatment device shall be lump sum and included with the underground detention system.**

END OF SECTION

State Road and Tollway Authority (SRTA), State of Georgia

SPECIAL PROVISION

Section 009 – Miscellaneous Construction – Emergency Call Box

Section 282600 – Emergency Call Box

PART 1 - GENERAL

1.1 INTRODUCTION

- A. The Emergency Call Boxes System (ECB) provide a way for patrons to report a crime, request assistance OR get information. There are FIVE (5) in the parking lot and two (2) in the pedestrian area around the bus shelters. The ECB system shall be furnished and installed by the Civil Contractor.

1.2 RELATED SECTIONS

- A. Section 26 05 19 - Low-Voltage Electrical Power Conductors and Cables (600 V and Less).
- B. Section 26 05 26 - Grounding and Bonding for Electronic Safety and Security.
- C. See Division 26 for all specifications governing the performance of work associated with the installation of raceway, system junction and pull boxes and device rough-in boxes for all work shown in the Electrical Drawing Package.
- D. Conduit, cable tray and back boxes for this system shall be furnished and installed by the civil contractor under the supervision of the SRTA.

1.3 EMERGENCY CALL BOX SYSTEM

- A. This Section specifies the requirements for the ECB system for Hickory Grove Park and Ride Lot. The ECB faceplate shall consist of a dual button hands-free automatic direct dial communications unit.
- B. The faceplate shall be equipped with a red push button labeled EMERGENCY and a black button labeled XPRESS INFO. The EMERGENCY push button shall be programmed to dial SRTA Operations Center for emergencies. The ECB shall dial a secondary backup SRTA number if the first number does not pickup. The XPRESS INFO button will dial a number to be determined at time of installation.

1.4 CONTRACTOR QUALIFICATIONS

- A. The Installation Contractor shall be or employ the services of a certified Code Blue Phone Reseller/Installer.
 - 1. At a minimum, one (1) on-site personnel shall have appropriate Code Blue Phone certification for installation, programming and troubleshooting.
 - 2. Provide a copy of Blue Light Certification.

PART 2 - PRODUCTS

2.1 CALL TOWER

A. The Call Tower shall meet the following minimum specifications:

1. Dimensions - 12" W X 10" D X 108" H with 2" radius corners.
2. Weight - 340 Lbs.
3. Construction - .025" steel w/multi-coat rust inhibitive coating for UV fading and graffiti protection.
4. Strobe - 1.5 million candlepower, 78 flashes per minute.
5. Safety blue strobe light -
 - Protective polycarbonate housing
 - 7.8 Watt high efficiency, LED
 - 1.5 million candlepower
 - 209 lumens peak
 - 78 flashes per minute
 - Lighting aging: 70% of initial lumens after 50,000 hours of operation
 - Faceplate Panel Light - Ultra bright LEDs, 50,000 Hour lifetime.
 - 120VAC, 5 Amp circuit
 - Lettering - 3.25" high reflective white letters.
 - Compliance - CSA Certified to UL Standard 60950

2.2 PHONE FACEPLATE AND INTERFACE MODULE

A. The call boxes shall meet the following minimum specifications;

1. Shall have a stainless-steel faceplate with a two (2) push buttons, an LED that illuminates when the call box is answered, for the hearing impaired. It will also be fitted with a vandal resistant speaker grill.
2. The Call Box shall be designed for flush mounting in a call tower. A separate blue strobe light shall be wall mounted above the call box in the tower as a location identifier. The blue light shall be normally illuminated for unit visibility. Pressing the EMERGENCY button will cause the blue light to flash for the duration of the call. Only when the called party terminates the call will the light stop flashing.
3. The Call Tower shall consist of the Call Box faceplate mounted in a free-standing vandal resistant tower with a blue strobe light mounted on its top.
4. The faceplate shall be continuously illuminated by LEDs mounted in the tower above the faceplate.
5. Call Towers shall have an analog adapter to allow a two-way communication via a VOIP system in the future.
6. Call tower to have a cell service interface module/ with antenna and be connected to the T-Mobile cellular service.

2.2 MATERIALS LIST

1. Code Blue Call Tower - Model ETP-MTR-PC (120Vac)
2. Code Blue Call Box – Model EEP-500ER
3. Code Blue Cellular interface unit ETP-GSM
4. Code Blue 12Vdc Power Supply- 86396

2.3 FINISH

1. The unit housing shall be fabricated of non-magnetic # 304 stainless steel and shall be powder coated after fabrication. The finish shall be uniform and free of visible defects.

PART 3 - EXECUTION

3.1 MOUNTING

- A. The column shall include four 5/8" x 16" J-bolts for mounting into a 20" X 20" X 3' concrete foundation. J-bolts shall protrude approximately 2 1/2" inches from surface of foundation.

3.2 ELECTRICAL

- A. The communication device shall be connected to 120VAC power.
- B. All electrical components shall be hard wired and concealed within the column in aluminum flex conduit. Lamps and fixtures, conduit, wiring and electrical fixtures comply with the standards of the National Electrical Code, UL.

3.3 WARRANTY

- A. Equipment shall be warranted against any defects in material and workmanship, under normal use, for a period of two years from date of purchase. In the event system is found by SRTA to be defective within the warranty period, manufacturer shall repair and/or replace any defective parts, provided the equipment is returned to manufacturer.

3.4 PAYMENT

- A. Lump sum price for Emergency Call Box (7) covers all items of work in this Special Provision including furnishing labor, materials, tools, equipment, and incidentals required to complete the work.

END OF SECTION

State Road and Tollway Authority (SRTA), State of Georgia

SPECIAL PROVISION

Section 999 – Electrical Construction – Lighting Complete

Section 262816 – Enclosed Switches and Circuit Breakers

PART 1 - GENERAL

1.1 RELATED DOCUMENTS

- A. Drawings and general provisions of the Contract, including General and Supplementary Conditions and other Division 01 Specification Sections, apply to this Section.

1.2 SUMMARY

- A. Section Includes:
 1. Fusible switches.
 2. Molded-case circuit breakers (MCCBs).
 3. Enclosures.

1.3 DEFINITIONS

- A. NC: Normally closed.
- B. NO: Normally open.
- C. SPDT: Single pole, double throw.

1.4 ACTION SUBMITTALS

- A. Product Data: For each type of enclosed switch, circuit breaker, accessory, and component indicated. Include nameplate ratings, dimensioned elevations, sections, weights, and manufacturers' technical data on features, performance, electrical characteristics, ratings, accessories, and finishes.
 1. Enclosure types and details for types other than NEMA 250, Type 1.
 2. Current and voltage ratings.
 3. Short-circuit current ratings (interrupting and withstand, as appropriate).
 4. Include evidence of a nationally recognized testing laboratory (NRTL) listing for series rating of installed devices.
 5. Detail features, characteristics, ratings, and factory settings of individual overcurrent protective devices, accessories, and auxiliary components.

6. Include time-current coordination curves (average melt) for each type and rating of overcurrent protective device; include selectable ranges for each type of overcurrent protective device. Provide in **PDF** electronic format.

B. Shop Drawings: For enclosed switches and circuit breakers.

1. Include plans, elevations, sections, details, and attachments to other work.
2. Include wiring diagrams for power, signal, and control wiring.

1.5 INFORMATIONAL SUBMITTALS

- A. Qualification Data:** For qualified testing agency.
- B. Field quality-control reports.**

1.6 CLOSEOUT SUBMITTALS

- A. Operation and Maintenance Data:** For enclosed switches and circuit breakers to include in emergency, operation, and maintenance manuals.
 1. In addition to items specified in Section 017823 "Operation and Maintenance Data," include the following:
 - a. Manufacturer's written instructions for testing and adjusting enclosed switches and circuit breakers.
 - b. Time-current coordination curves (average melt) for each type and rating of overcurrent protective device; include selectable ranges for each type of overcurrent protective device. Provide in **PDF** electronic format.

1.7 MAINTENANCE MATERIAL SUBMITTALS

- A. Furnish extra materials that match products installed and that are packaged with protective covering for storage and identified with labels describing contents.**
 1. **Fuses:** Equal to 10 percent of quantity installed for each size and type, but no fewer than three of each size and type.
 2. **Fuse Pullers:** Two for each size and type.

1.8 QUALITY ASSURANCE

- A. Testing Agency Qualifications:** Accredited by NETA.
 1. **Testing Agency's Field Supervisor:** Currently certified by NETA to supervise on-site testing.

1.9 FIELD CONDITIONS

- A. Environmental Limitations:** Rate equipment for continuous operation under the following conditions unless otherwise indicated:

1. Ambient Temperature: Not less than minus 22 deg F and not exceeding 104 deg F.
2. Altitude: Not exceeding 6600 feet.

1.10 WARRANTY

- A. **Manufacturer's Warranty:** Manufacturer and Installer agree to repair or replace components that fail in materials or workmanship within specified warranty period.
 1. **Warranty Period:** One year(s) from date of Substantial Completion.

PART 2 - PRODUCTS

2.1 PERFORMANCE REQUIREMENTS

- A. **Seismic Performance:** Enclosed switches and circuit breakers shall withstand the effects of earthquake motions determined according to ASCE/SEI 7.
 1. The term "withstand" means "the unit will remain in place without separation of any parts from the device when subjected to the seismic forces specified and the unit will be fully operational after the seismic event."

2.2 GENERAL REQUIREMENTS

- A. **Source Limitations:** Obtain enclosed switches and circuit breakers, overcurrent protective devices, components, and accessories, within same product category, from single manufacturer.
- B. **Product Selection for Restricted Space:** Drawings indicate maximum dimensions for enclosed switches and circuit breakers, including clearances between enclosures, and adjacent surfaces and other items. Comply with indicated maximum dimensions.
- C. **Electrical Components, Devices, and Accessories:** Listed and labeled as defined in NFPA 70, by an NRTL, and marked for intended location and application.
- D. Comply with NFPA 70.

2.3 FUSIBLE SWITCHES

- A. 1. Schneider Square D 2. General Electric GE 3. Siemens
- B. **Type HD, Heavy Duty:**
 1. Single throw.
 2. Three pole.
 3. 600-V ac.
 4. 200 A and smaller.
 5. UL 98 and NEMA KS 1, horsepower rated, with clips or bolt pads to accommodate specified fuses.

6. Lockable handle with capability to accept three padlocks, and interlocked with cover in closed position.

C. Accessories:

1. Equipment Ground Kit: Internally mounted and labeled for copper and aluminum ground conductors.
2. Neutral Kit: Internally mounted; insulated, capable of being grounded and bonded; labeled for copper neutral conductors.
3. Isolated Ground Kit: Internally mounted; insulated, labeled for copper and aluminum neutral conductors.
4. Class R Fuse Kit: Provides rejection of other fuse types when Class R fuses are specified.
5. Auxiliary Contact Kit: One NO/NC (Form "C") auxiliary contact(s), arranged to activate before switch blades open.
6. Hookstick Handle: Allows use of a hookstick to operate the handle.
7. Lugs: Mechanical type, suitable for number, size, and conductor material.
8. Service-Rated Switches: Labeled for use as service equipment.

2.4 MOLDED-CASE CIRCUIT BREAKERS

- A. 1. Schneider Square D 2. General Electric GE 3. Siemens
- B. Circuit breakers shall be constructed using glass-reinforced insulating material. Current carrying components shall be completely isolated from the handle and the accessory mounting area.
- C. Circuit breakers shall have a toggle operating mechanism with common tripping of all poles, which provides quick-make, quick-break contact action. The circuit-breaker handle shall be over center, be trip free, and reside in a tripped position between on and off to provide local trip indication. Circuit-breaker escutcheon shall be clearly marked on and off in addition to providing international I/O markings. Equip circuit breaker with a push-to-trip button, located on the face of the circuit breaker to mechanically operate the circuit-breaker tripping mechanism for maintenance and testing purposes.
- D. The maximum ampere rating and UL, IEC, or other certification standards with applicable voltage systems and corresponding interrupting ratings shall be clearly marked on face of circuit breaker. Circuit breakers shall be 100 percent rated. Circuit breaker/circuit breaker combinations for series connected interrupting ratings shall be listed by UL as recognized component combinations. Any series rated combination used shall be marked on the end-use equipment along with the statement "Caution - Series Rated System. _____ Amps Available. Identical Replacement Component Required."
- E. MCCBs shall be equipped with a device for locking in the isolated position.
- F. Lugs shall be suitable for 140 deg F rated wire on 125-A circuit breakers and below].
- G. Standard: Comply with UL 489 with interrupting capacity to comply with available fault currents.
- H. Thermal-Magnetic Circuit Breakers: Inverse time-current thermal element for low-level overloads and instantaneous magnetic trip element for short circuits. Adjustable magnetic trip setting for circuit-breaker frame sizes 250 A and larger.

- I. **Adjustable, Instantaneous-Trip Circuit Breakers:** Magnetic trip element with front-mounted, field-adjustable trip setting.
- J. **Electronic Trip Circuit Breakers:** Field-replaceable rating plug, rms sensing, with the following field-adjustable settings:
 - 1. Instantaneous trip.
 - 2. Long- and short-time pickup levels.
 - 3. Long- and short-time time adjustments.
 - 4. Ground-fault pickup level, time delay, and I-squared t response.
- K. **Current-Limiting Circuit Breakers:** Frame sizes 400 A and smaller, and let-through ratings less than NEMA FU 1, RK-5.
- L. **Integrally Fused Circuit Breakers:** Thermal-magnetic trip element with integral limiter-style fuse listed for use with circuit breaker and trip activation on fuse opening or on opening of fuse compartment door.
- M. **Ground-Fault Circuit-Interrupter (GFCI) Circuit Breakers:** Single- and two-pole configurations with Class A ground-fault protection (6-mA trip).
- N. **Ground-Fault Equipment-Protection (GFEP) Circuit Breakers:** With Class B ground-fault protection (30-mA trip).
- O. **Features and Accessories:**
 - 1. Standard frame sizes, trip ratings, and number of poles.
 - 2. Lugs: Compression type, suitable for number, size, trip ratings, and conductor material.
 - 3. Application Listing: Appropriate for application;
 - 4. Shunt Trip: Trip coil energized from separate circuit, with coil-clearing contact.
 - 5. Undervoltage Trip: Set to operate at 35 to 75 percent of rated voltage without intentional time delay.
 - 6. Auxiliary Contacts: One SPDT switch with "a" and "b" contacts; "a" contacts mimic circuit-breaker contacts, "b" contacts operate in reverse of circuit-breaker contacts.
 - 7. Alarm Switch: One NO NC contact that operates only when circuit breaker has tripped.

2.5 ENCLOSURES

- A. **Enclosed Switches and Circuit Breakers:** UL 489, NEMA KS 1, NEMA 250, and UL 50, to comply with environmental conditions at installed location.
- B. **Enclosure Finish:** The enclosure shall be finished with gray baked enamel paint, electrodeposited on cleaned, phosphatized steel (NEMA 250 Type 1) galvanized steel (NEMA 250 Types 3R).
- C. **Conduit Entry:** NEMA 250 Types 4, 4X, and 12 enclosures shall contain no knockouts. NEMA 250 Types 7 and 9 enclosures shall be provided with threaded conduit openings in both endwalls.
- D. **Operating Mechanism:** The circuit-breaker operating handle shall be externally operable with the operating mechanism being an integral part of the box, not the cover directly operable through the front cover of the enclosure (NEMA 250 Type 1) directly operable through the dead front trim of the enclosure (NEMA 250 Type 3R). The cover interlock mechanism shall have an

externally operated override. The override shall not permanently disable the interlock mechanism, which shall return to the locked position once the override is released. The tool used to override the cover interlock mechanism shall not be required to enter the enclosure in order to override the interlock.

PART 3 - EXECUTION

3.1 EXAMINATION

- A. Examine elements and surfaces to receive enclosed switches and circuit breakers for compliance with installation tolerances and other conditions affecting performance of the Work.
- B. Proceed with installation only after unsatisfactory conditions have been corrected.
 - 1. Commencement of work shall indicate Installer's acceptance of the areas and conditions as satisfactory.

3.2 PREPARATION

- A. Interruption of Existing Electric Service: Do not interrupt electric service to facilities occupied by Owner or others unless permitted under the following conditions and then only after arranging to provide temporary electric service according to requirements indicated:
 - 1. Notify Construction Manager no fewer than seven days in advance of proposed interruption of electric service.
 - 2. Indicate method of providing temporary electric service.
 - 3. Do not proceed with interruption of electric service without Construction Manager's written permission.
 - 4. Comply with NFPA 70E.

3.3 ENCLOSURE ENVIRONMENTAL RATING APPLICATIONS

- A. Enclosed Switches and Circuit Breakers: Provide enclosures at installed locations with the following environmental ratings.
 - 1. Indoor, Dry and Clean Locations: NEMA 250, Type 1.
 - 2. Outdoor Locations: NEMA 250, Type 3R.

3.4 INSTALLATION

- A. Coordinate layout and installation of switches, circuit breakers, and components with equipment served and adjacent surfaces. Maintain required workspace clearances and required clearances for equipment access doors and panels.
- B. Install individual wall-mounted switches and circuit breakers with tops at uniform height unless otherwise indicated.
- C. Comply with mounting and anchoring requirements specified in Section 260548.16 "Seismic Controls for Electrical Systems."

- D. Temporary Lifting Provisions: Remove temporary lifting of eyes, channels, and brackets and temporary blocking of moving parts from enclosures and components.
- E. Install fuses in fusible devices.
- F. Comply with NFPA 70 and NECA 1.

3.5 IDENTIFICATION

- A. Comply with requirements in Section 260553 "Identification for Electrical Systems."
 - 1. Identify field-installed conductors, interconnecting wiring, and components; provide warning signs.
 - 2. Label each enclosure with engraved metal or laminated-plastic nameplate.

3.6 FIELD QUALITY CONTROL

- A. Testing Agency: Owner will engage a qualified testing agency to perform tests and inspections.
- B. Testing Agency: Engage a qualified testing agency to perform tests and inspections.
- C. Manufacturer's Field Service: Engage a factory-authorized service representative to test and inspect components, assemblies, and equipment installations, including connections.
- D. Perform tests and inspections with the assistance of a factory-authorized service representative.
- E. Tests and Inspections for Switches:
 - 1. Visual and Mechanical Inspection:
 - a. Inspect physical and mechanical condition.
 - b. Inspect anchorage, alignment, grounding, and clearances.
 - c. Verify that the unit is clean.
 - d. Verify blade alignment, blade penetration, travel stops, and mechanical operation.
 - e. Verify that fuse sizes and types match the Specifications and Drawings.
 - f. Verify that each fuse has adequate mechanical support and contact integrity.
 - g. Inspect bolted electrical connections for high resistance using one of the two following methods:
 - 1) Use a low-resistance ohmmeter.
 - a) Compare bolted connection resistance values to values of similar connections. Investigate values that deviate from those of similar bolted connections by more than 50 percent of the lowest value.
 - 2) Verify tightness of accessible bolted electrical connections by calibrated torque-wrench method in accordance with manufacturer's published data or NETA ATS Table 100.12.
 - a) Bolt-torque levels shall be in accordance with manufacturer's published data. In the absence of manufacturer's published data, use NETA ATS Table 100.12.

- h. Verify that operation and sequencing of interlocking systems is as described in the Specifications and shown on the Drawings.
- i. Verify correct phase barrier installation.
- j. Verify lubrication of moving current-carrying parts and moving and sliding surfaces.

2. Electrical Tests:

- a. Perform resistance measurements through bolted connections with a low-resistance ohmmeter. Compare bolted connection resistance values to values of similar connections. Investigate values that deviate from adjacent poles or similar switches by more than 50 percent of the lowest value.
- b. Measure contact resistance across each switchblade fuseholder. Drop values shall not exceed the high level of the manufacturer's published data. If manufacturer's published data are not available, investigate values that deviate from adjacent poles or similar switches by more than 50 percent of the lowest value.
- c. Perform insulation-resistance tests for one minute on each pole, phase-to-phase and phase-to-ground with switch closed, and across each open pole. Apply voltage in accordance with manufacturer's published data. In the absence of manufacturer's published data, use Table 100.1 from the NETA ATS. Investigate values of insulation resistance less than those published in Table 100.1 or as recommended in manufacturer's published data.
- d. Measure fuse resistance. Investigate fuse-resistance values that deviate from each other by more than 15 percent.
- e. Perform ground fault test according to NETA ATS 7.14 "Ground Fault Protection Systems, Low-Voltage."

F. Tests and Inspections for Molded Case Circuit Breakers:

1. Visual and Mechanical Inspection:

- a. Verify that equipment nameplate data are as described in the Specifications and shown on the Drawings.
- b. Inspect physical and mechanical condition.
- c. Inspect anchorage, alignment, grounding, and clearances.
- d. Verify that the unit is clean.
- e. Operate the circuit breaker to ensure smooth operation.
- f. Inspect bolted electrical connections for high resistance using one of the two following methods:
 - 1) Use a low-resistance ohmmeter.
 - a) Compare bolted connection resistance values to values of similar connections. Investigate values that deviate from those of similar bolted connections by more than 50 percent of the lowest value.
 - 2) Verify tightness of accessible bolted electrical connections by calibrated torque-wrench method in accordance with manufacturer's published data or NETA ATS Table 100.12.
 - a) Bolt-torque levels shall be in accordance with manufacturer's published data. In the absence of manufacturer's published data, use NETA ATS Table 100.12.
- g. Inspect operating mechanism, contacts, and chutes in unsealed units.

- h. Perform adjustments for final protective device settings in accordance with the coordination study.
2. Electrical Tests:
- a. Perform resistance measurements through bolted connections with a low-resistance ohmmeter. Compare bolted connection resistance values to values of similar connections. Investigate values that deviate from adjacent poles or similar switches by more than 50 percent of the lowest value.
 - b. Perform insulation-resistance tests for one minute on each pole, phase-to-phase and phase-to-ground with circuit breaker closed, and across each open pole. Apply voltage in accordance with manufacturer's published data. In the absence of manufacturer's published data, use Table 100.1 from the NETA ATS. Investigate values of insulation resistance less than those published in Table 100.1 or as recommended in manufacturer's published data.
 - c. Perform a contact/pole resistance test. Drop values shall not exceed the high level of the manufacturer's published data. If manufacturer's published data are not available, investigate values that deviate from adjacent poles or similar switches by more than 50 percent of the lowest value.
 - d. Perform insulation resistance tests on all control wiring with respect to ground. Applied potential shall be 500-V dc for 300-V rated cable and 1000-V dc for 600-V rated cable. Test duration shall be one minute. For units with solid state components, follow manufacturer's recommendation. Insulation resistance values shall be no less than two megohms.
 - e. Determine the following by primary current injection:
 - 1) Long-time pickup and delay. Pickup values shall be as specified. Trip characteristics shall not exceed manufacturer's published time-current characteristic tolerance band, including adjustment factors.
 - 2) Short-time pickup and delay. Short-time pickup values shall be as specified. Trip characteristics shall not exceed manufacturer's published time-current characteristic tolerance band, including adjustment factors.
 - 3) Ground-fault pickup and time delay. Ground-fault pickup values shall be as specified. Trip characteristics shall not exceed manufacturer's published time-current characteristic tolerance band, including adjustment factors.
 - 4) Instantaneous pickup. Instantaneous pickup values shall be as specified and within manufacturer's published tolerances.
 - f. Test functionality of the trip unit by means of primary current injection. Pickup values and trip characteristics shall be as specified and within manufacturer's published tolerances.
 - g. Perform minimum pickup voltage tests on shunt trip and close coils in accordance with manufacturer's published data. Minimum pickup voltage of the shunt trip and close coils shall be as indicated by manufacturer.
 - h. Verify correct operation of auxiliary features such as trip and pickup indicators; zone interlocking; electrical close and trip operation; trip-free, anti-pump function; and trip unit battery condition. Reset all trip logs and indicators. Investigate units that do not function as designed.
 - i. Verify operation of charging mechanism. Investigate units that do not function as designed.
3. Correct malfunctioning units on-site, where possible, and retest to demonstrate compliance; otherwise, replace with new units and retest.
4. Perform the following infrared scan tests and inspections and prepare reports:

- a. **Initial Infrared Scanning:** After Substantial Completion, but not more than 60 days after Final Acceptance, perform an infrared scan of each enclosed switch and circuit breaker. Remove front panels so joints and connections are accessible to portable scanner.
 - b. **Follow-up Infrared Scanning:** Perform an additional follow-up infrared scan of each enclosed switch and circuit breaker 11 months after date of Substantial Completion.
 - c. **Instruments and Equipment:** Use an infrared scanning device designed to measure temperature or to detect significant deviations from normal values. Provide calibration record for device.
5. Test and adjust controls, remote monitoring, and safeties. Replace damaged and malfunctioning controls and equipment.
- G. Enclosed switches and circuit breakers will be considered defective if they do not pass tests and inspections.
- H. Prepare test and inspection reports.
- 1. Test procedures used.
 - 2. Include identification of each enclosed switch and circuit breaker tested and describe test results.
 - 3. List deficiencies detected, remedial action taken, and observations after remedial action.

3.7 ADJUSTING

- A. Adjust moving parts and operable components to function smoothly, and lubricate as recommended by manufacturer.
- B. Set field-adjustable circuit-breaker trip ranges.

3.8 PAYMENT

- A. Lump sum price for Electrical Construction – Lighting Complete covers all items of work in this Special Provision including furnishing labor, materials, tools, equipment, and incidentals required to complete the work.

State Road and Tollway Authority (SRTA), State of Georgia

SPECIAL PROVISION

Section 999 – Electrical Construction – Lighting Complete

Section 262813 – Fuses

PART 1 - GENERAL

1.1 RELATED DOCUMENTS

- A. Drawings and general provisions of the Contract, including General and Supplementary Conditions and Division 01 Specification Sections, apply to this Section.

1.2 SUMMARY

- A. Section Includes:

1. Cartridge fuses rated 600 V ac and less for use in the following:
 - a. Enclosed switches.
2. Spare-fuse cabinets.

1.3 ACTION SUBMITTALS

- A. **Product Data:** For each type of product. Include construction details, material descriptions, dimensions of individual components and profiles, and finishes for spare-fuse cabinets. Include the following for each fuse type indicated:
1. **Ambient Temperature Adjustment Information:** If ratings of fuses have been adjusted to accommodate ambient temperatures, provide list of fuses with adjusted ratings.
 - a. For each fuse having adjusted ratings, include location of fuse, original fuse rating, local ambient temperature, and adjusted fuse rating.
 - b. Provide manufacturer's technical data on which ambient temperature adjustment calculations are based.
 2. Dimensions and manufacturer's technical data on features, performance, electrical characteristics, and ratings.
 3. Current-limitation curves for fuses with current-limiting characteristics.
 4. Time-current coordination curves (average melt) and current-limitation curves (instantaneous peak let-through current) for each type and rating of fuse. Submit in PDF format.
 5. Coordination charts and tables and related data.
 6. Fuse sizes for elevator feeders and elevator disconnect switches.

1.4 CLOSEOUT SUBMITTALS

- A. **Operation and Maintenance Data:** For fuses to include in emergency, operation, and maintenance manuals. In addition to items specified in Section 017700 "Closeout Procedures," Section 017823 "Operation and Maintenance Data," include the following:
1. Ambient temperature adjustment information.
 2. Current-limitation curves for fuses with current-limiting characteristics.
 3. Time-current coordination curves (average melt) and current-limitation curves (instantaneous peak let-through current) for each type and rating of fuse used on the Project. Submit in PDF format.
 4. Coordination charts and tables and related data.

1.5 MAINTENANCE MATERIAL SUBMITTALS

- A. Furnish extra materials that match products installed and that are packaged with protective covering for storage and identified with labels describing contents.
1. Fuses: Equal to 10 percent of quantity installed for each size and type, but no fewer than three of each size and type.

1.6 FIELD CONDITIONS

- A. Where ambient temperature to which fuses are directly exposed is less than 40 deg F or more than , apply manufacturer's ambient temperature adjustment factors to fuse ratings.

PART 2 - PRODUCTS

2.1 MANUFACTURERS

- A. 1. Little Fuse 2. Bussman 3. Ferraz Shamut
- B. **Source Limitations:** Obtain fuses, for use within a specific product or circuit, from single source from single manufacturer.

2.2 CARTRIDGE FUSES

- A. **Characteristics:** NEMA FU 1, current-limiting, nonrenewable cartridge fuses with voltage ratings consistent with circuit voltages.
1. Type RK-1: 600-V, zero- to 600-A rating, 200 kAIC, time delay.
 2. Type RK-5: 600-V, zero- to 600-A rating, 200 kAIC, time delay].
 3. Type CC: 600-V, zero- to 30-A rating, 200 kAIC, fast acting, time delay.
 4. Type CD: 600-V, 31- to 60-A rating, 200 kAIC, fast acting , time delay.
 5. Type J: 600-V, zero- to 600-A rating, 200 kAIC, time delay.
- B. **Electrical Components, Devices, and Accessories:** Listed and labeled as defined in NFPA 70, by a qualified testing agency, and marked for intended location and application.

- C. Comply with NEMA FU 1 for cartridge fuses.
- D. Comply with NFPA 70.
- E. Coordinate fuse ratings with utilization equipment nameplate limitations of maximum fuse size and with system short-circuit current levels.

2.3 SPARE-FUSE CABINET

- A. Characteristics: Wall-mounted steel unit with full-length, recessed piano-hinged door and key-coded cam lock and pull.
 1. Size: Adequate for storage of spare fuses specified with 10 percent spare capacity minimum.
 2. Finish: Gray, baked enamel.
 3. Identification: "SPARE FUSES" in 1-1/2-inch- high letters on exterior of door.
 4. Fuse Pullers: For each size of fuse, where applicable and available, from fuse manufacturer.

PART 3 - EXECUTION

3.1 EXAMINATION

- A. Examine fuses before installation. Reject fuses that are moisture damaged or physically damaged.
- B. Examine holders to receive fuses for compliance with installation tolerances and other conditions affecting performance, such as rejection features.
- C. Examine utilization equipment nameplates and installation instructions. Install fuses of sizes and with characteristics appropriate for each piece of equipment.
- D. Evaluate ambient temperatures to determine if fuse rating adjustment factors must be applied to fuse ratings.
- E. Proceed with installation only after unsatisfactory conditions have been corrected.

3.2 FUSE APPLICATIONS

- A. Cartridge Fuses:
 1. Motor Branch Circuits: Class RK1 Class RK5 Class CC, motor duty, time delay.
 2. Control Transformer Circuits: Class CC, time delay, control transformer duty.
 3. Provide open-fuse indicator fuses or fuse covers with open fuse indication.

3.3 INSTALLATION

- A. Install fuses in fusible devices. Arrange fuses so rating information is readable without removing fuse.

- B. Install spare-fuse cabinet(s) in location shown on the Drawings or as indicated in the field by Construction Manager.

3.4 IDENTIFICATION

- A. Install labels complying with requirements for identification specified in Section 260553 "Identification for Electrical Systems" and indicating fuse replacement information inside of door of each fused switch and adjacent to each fuse block, socket, and holder.

3.5 PAYMENT

- A. Lump sum price for Electrical Construction – Lighting Complete covers all items of work in this Special Provision including furnishing labor, materials, tools, equipment, and incidentals required to complete the work.

END OF SECTION

State Road and Tollway Authority (SRTA), State of Georgia

SPECIAL PROVISION

Section 999 – Electrical Construction – Lighting Complete

Section 260526 – Grounding and Bonding for Electrical Systems

PART 1 - GENERAL

1.1 RELATED DOCUMENTS

- A. Drawings and general provisions of the Contract, including General and Supplementary Conditions and Division 01 Specification Sections, apply to this Section.

1.2 SUMMARY

- A. Section includes grounding and bonding systems and equipment.
- B. Section includes grounding and bonding systems and equipment, plus the following special applications:
 1. Underground distribution grounding.
 2. Ground bonding common with lightning protection system.
 3. Foundation steel electrodes.

1.3 ACTION SUBMITTALS

- A. Product Data: For each type of product indicated.

1.4 INFORMATIONAL SUBMITTALS

- A. Coordination Drawings: Plans showing dimensioned locations of grounding features specified in "Field Quality Control" Article, including the following:
 1. Test wells.
 2. Ground rods.
- B. Qualification Data: For testing agency and testing agency's field supervisor.
- C. Field quality-control reports.

1.5 CLOSEOUT SUBMITTALS

- A. Operation and Maintenance Data: For grounding to include in emergency, operation, and maintenance manuals.
 - 1. In addition to items specified in Section 017823 "Operation and Maintenance Data," include the following:
 - a. Plans showing as-built, dimensioned locations of grounding features specified in "Field Quality Control" Article, including the following:
 - 1) Test wells.
 - 2) Ground rods.
 - b. Instructions for periodic testing and inspection of grounding features at test wells based on NFPA 70B.
 - 1) Tests shall determine if ground-resistance or impedance values remain within specified maximums, and instructions shall recommend corrective action if values do not.
 - 2) Include recommended testing intervals.

1.6 QUALITY ASSURANCE

- A. Testing Agency Qualifications: Certified by NETA.

PART 2 - PRODUCTS

2.1 SYSTEM DESCRIPTION

- A. Electrical Components, Devices, and Accessories: Listed and labeled as defined in NFPA 70, by a qualified testing agency, and marked for intended location and application.
- B. Comply with UL 467 for grounding and bonding materials and equipment.

2.2 MANUFACTURERS

- A. 1. Erico 2. Hager Lightning Protection 3. Thomas and Belts.

2.3 CONDUCTORS

- A. Insulated Conductors: Copper or tinned-copper wire or cable insulated for 600 V unless otherwise required by applicable Code or authorities having jurisdiction.
- B. Bare Copper Conductors:
 - 1. Solid Conductors: ASTM B 3.
 - 2. Stranded Conductors: ASTM B 8.
 - 3. Tinned Conductors: ASTM B 33.

4. **Bonding Cable:** 28 kcmil, 14 strands of No. 17 AWG conductor, 1/4 inch in diameter.
 5. **Bonding Conductor:** No. 4 or No. 6 AWG, stranded conductor.
 6. **Bonding Jumper:** Copper tape, braided conductors terminated with copper ferrules; 1-5/8 inches wide and 1/16 inch thick.
 7. **Tinned Bonding Jumper:** Tinned-copper tape, braided conductors terminated with copper ferrules; 1-5/8 inches wide and 1/16 inch thick.
- C. **Grounding Bus:** Predrilled rectangular bars of annealed copper, 1/4 by 4 inches in cross section, with 9/32-inch holes spaced 1-1/8 inches apart. Stand-off insulators for mounting shall comply with UL 891 for use in switchboards, 600 V and shall be Lexan or PVC, impulse tested at 5000 V.

2.4 CONNECTORS

- A. Listed and labeled by an NRTL acceptable to authorities having jurisdiction for applications in which used and for specific types, sizes, and combinations of conductors and other items connected.
- B. **Welded Connectors:** Exothermic-welding kits of types recommended by kit manufacturer for materials being joined and installation conditions.
- C. **Bus-Bar Connectors:** Mechanical type, cast silicon bronze, solderless exothermic-type wire terminals, and long-barrel, two-bolt connection to ground bus bar.
- D. **Bus-Bar Connectors:** Compression type, copper or copper alloy, with two wire terminals.
- E. **Beam Clamps:** Mechanical type, terminal, ground wire access from four directions, with dual, tin-plated or silicon bronze bolts.
- F. **Cable-to-Cable Connectors:** Compression type, copper or copper alloy.
- G. **Cable Tray Ground Clamp:** Mechanical type, zinc-plated malleable iron.
- H. **Conduit Hubs:** Mechanical type, terminal with threaded hub.
- I. **Ground Rod Clamps:** Mechanical type, copper or copper alloy, terminal with hex head bolt.
- J. **Ground Rod Clamps:** Mechanical type, copper or copper alloy, terminal with hex head bolt.
- K. **Service Post Connectors:** Mechanical type, bronze alloy terminal, in short- and long-stud lengths, capable of single and double conductor connections.
- L. **Signal Reference Grid Clamp:** Mechanical type, stamped-steel terminal with hex head screw.
- M. **Straps:** Solid copper, copper lugs. Rated for 600 A.
- N. **Tower Ground Clamps:** Mechanical type, copper or copper alloy, terminal one-piece clamp.
- O. **U-Bolt Clamps:** Mechanical type, copper or copper alloy, terminal listed for direct burial.
- P. **Water Pipe Clamps:**
 1. Mechanical type, two pieces with zinc-plated bolts.

- a. Material: [Tin-plated aluminum.
 - b. Listed for direct burial.
2. U-bolt type with malleable-iron clamp and copper ground connector

2.5 GROUNDING ELECTRODES

- A. Ground Rods: Copper-clad steel, sectional type 3/4 by 120 inches.
- B. Chemical-Enhanced Grounding Electrodes: Copper tube, straight or L-shaped, charged with nonhazardous electrolytic chemical salts.
 1. Termination: Factory-attached No. 4/0 AWG bare conductor at least 48 inches long.
 2. Backfill Material: Electrode manufacturer's recommended material.
- C. Ground Plates: 1/4 inch thick, hot-dip galvanized.

PART 3 - EXECUTION

3.1 APPLICATIONS

- A. Conductors: Install solid conductor for No. 8 AWG and smaller, and stranded conductors for No. 6 AWG and larger unless otherwise indicated.
- B. Underground Grounding Conductors: Install bare tinned-copper conductor, No. 2/0 AWG minimum.
 1. Bury at least 24 inches below grade.
 2. Duct-Bank Grounding Conductor: Bury 12 inches above duct bank when indicated as part of duct-bank installation.
- C. Isolated Grounding Conductors: Green-colored insulation with continuous yellow stripe. On feeders with isolated ground, identify grounding conductor where visible to normal inspection, with alternating bands of green and yellow tape, with at least three bands of green and two bands of yellow.
- D. Grounding Bus: Install in electrical equipment rooms, in rooms housing service equipment, and elsewhere as indicated.
 1. Install bus horizontally, on insulated spacers 2 inches minimum from wall, 6 inches above finished floor unless otherwise indicated.
 2. Where indicated on both sides of doorways, route bus up to top of door frame, across top of doorway, and down; connect to horizontal bus.
- E. Conductor Terminations and Connections:
 1. Pipe and Equipment Grounding Conductor Terminations: Bolted connectors.
 2. Underground Connections: Welded connectors except at test wells and as otherwise indicated.
 3. Connections to Ground Rods at Test Wells: Bolted connectors.
 4. Connections to Structural Steel: Welded connectors.

3.2 GROUNDING AT THE SERVICE

- A. Equipment grounding conductors and grounding electrode conductors shall be connected to the ground bus. Install a main bonding jumper between the neutral and ground buses.

3.3 EQUIPMENT GROUNDING

- A. Install insulated equipment grounding conductors with all feeders and branch circuits.
- B. Install insulated equipment grounding conductors with the following items, in addition to those required by NFPA 70:
 1. Feeders and branch circuits.
 2. Lighting circuits.
 3. Receptacle circuits.
 4. Single-phase motor and appliance branch circuits.
 5. Three-phase motor and appliance branch circuits.
 6. Flexible raceway runs.
- C. **Isolated Grounding Receptacle Circuits:** Install an insulated equipment grounding conductor connected to the receptacle grounding terminal. Isolate conductor from raceway and from panelboard grounding terminals. Terminate at equipment grounding conductor terminal of the applicable derived system or service unless otherwise indicated.
- D. **Isolated Equipment Enclosure Circuits:** For designated equipment supplied by a branch circuit or feeder, isolate equipment enclosure from supply circuit raceway with a nonmetallic raceway fitting listed for the purpose. Install fitting where raceway enters enclosure, and install a separate insulated equipment grounding conductor. Isolate conductor from raceway and from panelboard grounding terminals. Terminate at equipment grounding conductor terminal of the applicable derived system or service unless otherwise indicated.
- E. **Poles Supporting Outdoor Lighting Fixtures:** Install grounding electrode and a separate insulated equipment grounding conductor in addition to grounding conductor installed with branch-circuit conductors.
- F. **Metallic Fences:** Comply with requirements of IEEE C2.
 1. Grounding Conductor: Bare, tinned copper, not less than No. 8 AWG.
 2. Gates: Shall be bonded to the grounding conductor with a flexible bonding jumper.
 3. Barbed Wire: Strands shall be bonded to the grounding conductor.

3.4 INSTALLATION

- A. **Grounding Conductors:** Route along shortest and straightest paths possible unless otherwise indicated or required by Code. Avoid obstructing access or placing conductors where they may be subjected to strain, impact, or damage.
- B. **Ground Bonding Common with Lightning Protection System:** Comply with NFPA 780 and UL 96 when interconnecting with lightning protection system. Bond electrical power system ground directly to lightning protection system grounding conductor at closest point to electrical service grounding electrode. Use bonding conductor sized same as system grounding electrode conductor, and install in conduit.

- C. **Ground Rods:** Drive rods until tops are 2 inches below finished floor or final grade unless otherwise indicated.
1. Interconnect ground rods with grounding electrode conductor below grade and as otherwise indicated. Make connections without exposing steel or damaging coating if any.
 2. Use exothermic welds for all below-grade connections.
 3. For grounding electrode system, install at least [three] <Insert number> rods spaced at least one-rod length from each other and located at least the same distance from other grounding electrodes, and connect to the service grounding electrode conductor.
- D. **Test Wells:** Ground rod driven through drilled hole in bottom of handhole. Handholes are specified in Section 260543 "Underground Ducts and Raceways for Electrical Systems," and shall be at least 12 inches deep, with cover.
1. Install at least one test well for each service unless otherwise indicated. Install at the ground rod electrically closest to service entrance. Set top of test well flush with finished grade or floor.
- E. **Bonding Straps and Jumpers:** Install in locations accessible for inspection and maintenance except where routed through short lengths of conduit.
1. **Bonding to Structure:** Bond straps directly to basic structure, taking care not to penetrate any adjacent parts.
 2. **Bonding to Equipment Mounted on Vibration Isolation Hangers and Supports:** Install bonding so vibration is not transmitted to rigidly mounted equipment.
 3. Use exothermic-welded connectors for outdoor locations; if a disconnect-type connection is required, use a bolted clamp.
- F. **Grounding and Bonding for Piping:**
1. **Metal Water Service Pipe:** Install insulated copper grounding conductors, in conduit, from building's main service equipment, or grounding bus, to main metal water service entrances to building. Connect grounding conductors to main metal water service pipes; use a bolted clamp connector or bolt a lug-type connector to a pipe flange by using one of the lug bolts of the flange. Where a dielectric main water fitting is installed, connect grounding conductor on street side of fitting. Bond metal grounding conductor conduit or sleeve to conductor at each end.
 2. **Water Meter Piping:** Use braided-type bonding jumpers to electrically bypass water meters. Connect to pipe with a bolted connector.
 3. Bond each aboveground portion of gas piping system downstream from equipment shutoff valve.
- G. **Bonding Interior Metal Ducts:** Bond metal air ducts to equipment grounding conductors of associated fans, blowers, electric heaters, and air cleaners. Install tinned bonding jumper to bond across flexible duct connections to achieve continuity.
- H. **Grounding for Steel Building Structure:** Install a driven ground rod at base of each corner column and at intermediate exterior columns at distances not more than 60 feet apart.
- I. **Connections:** Make connections so possibility of galvanic action or electrolysis is minimized. Select connectors, connection hardware, conductors, and connection methods so metals in direct contact are galvanically compatible.

1. Use electroplated or hot-tin-coated materials to ensure high conductivity and to make contact points closer in order of galvanic series.
2. Make connections with clean, bare metal at points of contact.
3. Make aluminum-to-steel connections with stainless-steel separators and mechanical clamps.
4. Make aluminum-to-galvanized-steel connections with tin-plated copper jumpers and mechanical clamps.
5. Coat and seal connections having dissimilar metals with inert material to prevent future penetration of moisture to contact surfaces.

3.5 FIELD QUALITY CONTROL

- A. Testing Agency: Owner will engage a qualified testing agency to perform tests and inspections.
- B. Testing Agency: Engage a qualified testing agency to perform tests and inspections.
- C. Manufacturer's Field Service: Engage a factory-authorized service representative to test and inspect components, assemblies, and equipment installations, including connections.
- D. Perform tests and inspections with the assistance of a factory-authorized service representative.
- E. Tests and Inspections:
 1. After installing grounding system but before permanent electrical circuits have been energized, test for compliance with requirements.
 2. Inspect physical and mechanical condition. Verify tightness of accessible, bolted, electrical connections with a calibrated torque wrench according to manufacturer's written instructions.
 3. Test completed grounding system at each location where a maximum ground-resistance level is specified, at service disconnect enclosure grounding terminal, at ground test wells, and at individual ground rods. Make tests at ground rods before any conductors are connected.
 - a. Measure ground resistance no fewer than two full days after last trace of precipitation and without soil being moistened by any means other than natural drainage or seepage and without chemical treatment or other artificial means of reducing natural ground resistance.
 - b. Perform tests by fall-of-potential method according to IEEE 81.
 4. Prepare dimensioned Drawings locating each test well, ground rod and ground-rod assembly, and other grounding electrodes. Identify each by letter in alphabetical order, and key to the record of tests and observations. Include the number of rods driven and their depth at each location, and include observations of weather and other phenomena that may affect test results. Describe measures taken to improve test results.
- F. Grounding system will be considered defective if it does not pass tests and inspections.
- G. Prepare test and inspection reports.
- H. Report measured ground resistances that exceed the following values:
 1. Power and Lighting Equipment or System with Capacity of 500 kVA and Less: 10 ohms.

- I. **Excessive Ground Resistance:** If resistance to ground exceeds specified values, notify Architect promptly and include recommendations to reduce ground resistance.

3.6 PAYMENT

- A. Lump sum price for Electrical Construction – Lighting Complete covers all items of work in this Special Provision including furnishing labor, materials, tools, equipment, and incidentals required to complete the work.

END OF SECTION

State Road and Tollway Authority (SRTA), State of Georgia

SPECIAL PROVISION

Section 999 – Electrical Construction – Lighting Complete

Section 260529 – Hangers and Supports for Electrical Systems

PART 1 - GENERAL

1.1 RELATED DOCUMENTS

- A. Drawings and general provisions of the Contract, including General and Supplementary Conditions and Division 01 Specification Sections, apply to this Section.

1.2 SUMMARY

- A. Section Includes:
 1. Steel slotted support systems.
 2. Conduit and cable support devices.
 3. Support for conductors in vertical conduit.
 4. Structural steel for fabricated supports and restraints.
 5. Mounting, anchoring, and attachment components, including powder-actuated fasteners, mechanical expansion anchors, concrete inserts, clamps, through bolts, toggle bolts, and hanger rods.
 6. Fabricated metal equipment support assemblies.

1.3 ACTION SUBMITTALS

- A. Product Data: For each type of product.
 1. Include construction details, material descriptions, dimensions of individual components and profiles, and finishes for the following:
 - a. Slotted support systems, hardware, and accessories.
 - b. Clamps.
 - c. Hangers.
 - d. Sockets.
 - e. Eye nuts.
 - f. Fasteners.
 - g. Anchors.
 - h. Saddles.
 - i. Brackets.
 2. Include rated capacities and furnished specialties and accessories.

- B. **Shop Drawings** For fabrication and installation details for electrical hangers and support systems.
 - 1. Hangers. Include product data for components.
 - 2. Slotted support systems.
 - 3. Equipment supports.
- C. **Delegated-Design Submittal:** For hangers and supports for electrical systems.
 - 1. Include design calculations and details of hangers.

1.4 INFORMATIONAL SUBMITTALS

- A. **Coordination Drawings:** Reflected ceiling plan(s) and other details, drawn to scale, on which the following items are shown and coordinated with each other, using input from installers of the items involved:
 - 1. Suspended ceiling components.
 - 2. Structural members to which hangers and supports will be attached.
 - 3. Size and location of initial access modules for acoustical tile.
 - 4. Items penetrating finished ceiling, including the following:
 - a. Luminaires.
- B. **Seismic Qualification Data:** Certificates, for hangers and supports for electrical equipment and systems, accessories, and components, from manufacturer.
 - 1. **Basis for Certification:** Indicate whether withstand certification is based on actual test of assembled components or on calculation.
 - 2. **Dimensioned Outline Drawings of Equipment Unit:** Identify center of gravity and locate and describe mounting and anchorage provisions.
 - 3. Detailed description of equipment anchorage devices on which the certification is based and their installation requirements.
- C. Welding certificates.

1.5 QUALITY ASSURANCE

- A. **Welding Qualifications:** Qualify procedures and personnel according to **AWS D1.1/D1.1M AWS D1.2/D1.2M**].
- B. **Welding Qualifications:** Qualify procedures and personnel according to the following:
 - 1. AWS D1.1/D1.1M.
 - 2. AWS D1.2/D1.2M.

PART 2 - PRODUCTS

2.1 PERFORMANCE REQUIREMENTS

- A. **Delegated Design:** Engage a qualified professional engineer, as defined in Section 014000 "Quality Requirements," to design hanger and support system.
- B. **Surface-Burning Characteristics:** Comply with ASTM E 84; testing by a qualified testing agency. Identify products with appropriate markings of applicable testing agency.
 - 1. **Flame Rating:** Class 1.
 - 2. **Self-extinguishing** according to ASTM D 635.

2.2 SUPPORT, ANCHORAGE, AND ATTACHMENT COMPONENTS

- A. **Steel Slotted Support Systems:** Preformed steel channels and angles with minimum 13/32-inch-diameter holes at a maximum of 8 inches o.c. in at least one surface.
 - 1. **Standard:** Comply with MFMA-4 factory-fabricated components for field assembly.
 - 2. **Material for Channel, Fittings, and Accessories:** **Galvanized steel.**
 - 3. **Channel Width:** **Selected for applicable load criteria 1-5/8 inches.**
 - 4. **Painted Coatings:** Manufacturer's standard painted coating applied according to MFMA-4.
 - 5. **Protect finishes on exposed surfaces from damage** by applying a strippable, temporary protective covering before shipping.
 - 6.
- B. **Conduit and Cable Support Devices:** **Steel** hangers, clamps, and associated fittings, designed for types and sizes of raceway or cable to be supported.
- C. **Support for Conductors in Vertical Conduit:** Factory-fabricated assembly consisting of threaded body and insulating wedging plug or plugs for nonarmored electrical conductors or cables in riser conduits. Plugs shall have number, size, and shape of conductor gripping pieces as required to suit individual conductors or cables supported. Body shall be made of malleable iron.
- D. **Structural Steel for Fabricated Supports and Restraints:** ASTM A 36/A 36M steel plates, shapes, and bars; black and galvanized.
- E. **Mounting, Anchoring, and Attachment Components:** Items for fastening electrical items or their supports to building surfaces include the following:
 - 1. **Powder-Actuated Fasteners:** Threaded-steel stud, for use in hardened portland cement concrete, steel, or wood, with tension, shear, and pullout capacities appropriate for supported loads and building materials where used.
 - 2. **Mechanical-Expansion Anchors:** Insert-wedge-type, **zinc-coated** steel, for use in hardened portland cement concrete, with tension, shear, and pullout capacities appropriate for supported loads and building materials where used.
 - 3. **Concrete Inserts:** Steel or malleable-iron, slotted support system units are similar to MSS Type 18 units and comply with MFMA-4 or MSS SP-58.

4. Clamps for Attachment to Steel Structural Elements: MSS SP-58 units are suitable for attached structural element.
5. Through Bolts: Structural type, hex head, and high strength. Comply with ASTM A 325.
6. Toggle Bolts: **[All] [Stainless]**-steel springhead type.
7. Hanger Rods: Threaded steel.

2.3 FABRICATED METAL EQUIPMENT SUPPORT ASSEMBLIES

- A. Description: Welded or bolted structural-steel shapes, shop or field fabricated to fit dimensions of supported equipment.
- B. Materials: Comply with requirements in Section 055000 "Metal Fabrications" for steel shapes and plates.

PART 3 - EXECUTION

3.1 APPLICATION

- A. Comply with the following standards for application and installation requirements of hangers and supports, except where requirements on Drawings or in this Section are stricter:
 1. NECA 1.
 2. NECA 101
 3. NECA 102.
 4. NECA 105.
 5. NECA 111.
- B. Comply with requirements in Section 078413 "Penetration Firestopping" for firestopping materials and installation for penetrations through fire-rated walls, ceilings, and assemblies.
- C. Comply with requirements for raceways and boxes specified in Section 260533 "Raceways and Boxes for Electrical Systems."
- D. Maximum Support Spacing and Minimum Hanger Rod Size for Raceways: Space supports for EMT, IMC, and RMC as required by NFPA 70. Minimum rod size shall be 1/4 inch in diameter.
- E. Multiple Raceways or Cables: Install trapeze-type supports fabricated with steel slotted support system, sized so capacity can be increased by at least **25** percent in future without exceeding specified design load limits.
 1. Secure raceways and cables to these supports with two-bolt conduit clamps.
- F. Spring-steel clamps designed for supporting single conduits without bolts may be used for 1-1/2-inch and smaller raceways serving branch circuits and communication systems above suspended ceilings, and for fastening raceways to trapeze supports.

3.2 SUPPORT INSTALLATION

- A. Comply with NECA 1 and NECA 101 for installation requirements except as specified in this article.

- B. Raceway Support Methods: In addition to methods described in NECA 1, EMT, IMC and RMC may be supported by openings through structure members, according to NFPA 70.
- C. Strength of Support Assemblies: Where not indicated, select sizes of components so strength will be adequate to carry present and future static loads within specified loading limits. Minimum static design load used for strength determination shall be weight of supported components plus 200 lb.
- D. Mounting and Anchorage of Surface-Mounted Equipment and Components: Anchor and fasten electrical items and their supports to building structural elements by the following methods unless otherwise indicated by code:
 1. To Wood: Fasten with lag screws or through bolts.
 2. To New Concrete: Bolt to concrete inserts.
 3. To Masonry: Approved toggle-type bolts on hollow masonry units and expansion anchor fasteners on solid masonry units.
 4. To Existing Concrete: Expansion anchor fasteners.
 5. Instead of expansion anchors, powder-actuated driven threaded studs provided with lock washers and nuts may be used in existing standard-weight concrete 4 inches thick or greater. Do not use for anchorage to lightweight-aggregate concrete or for slabs less than 4 inches thick.
 6. To Steel: Welded threaded studs complying with AWS D1.1/D1.1M, with lock washers and nuts.
 7. To Light Steel: Sheet metal screws.
- E. Drill holes for expansion anchors in concrete at locations and to depths that avoid the need for reinforcing bars.

3.3 INSTALLATION OF FABRICATED METAL SUPPORTS

- A. Comply with installation requirements in Section 055000 "Metal Fabrications" for site-fabricated metal supports.
- B. Cut, fit, and place miscellaneous metal supports accurately in location, alignment, and elevation to support and anchor electrical materials and equipment.
- C. Field Welding: Comply with AWS D1.1/D1.1M.

3.4 CONCRETE BASES

- A. Construct concrete bases of dimensions indicated, but not less than 4 inches larger in both directions than supported unit, and so anchors will be a minimum of 10 bolt diameters from edge of the base.
- B. Use 3000-psi, 28-day compressive-strength concrete. Concrete materials, reinforcement, and placement requirements are specified in **Section 033000 "Cast-in-Place Concrete."**
- C. Anchor equipment to concrete base as follows:
 1. Place and secure anchorage devices. Use supported equipment manufacturer's setting drawings, templates, diagrams, instructions, and directions furnished with items to be embedded.
 2. Install anchor bolts to elevations required for proper attachment to supported equipment.

3. Install anchor bolts according to anchor-bolt manufacturer's written instructions.

3.5 PAINTING

- A. Touchup: Clean field welds and abraded areas of shop paint. Paint exposed areas immediately after erecting hangers and supports. Use same materials as used for shop painting. Comply with SSPC-PA 1 requirements for touching up field-painted surfaces.
 1. Apply paint by brush or spray to provide minimum dry film thickness of 2.0 mils.
- B. Touchup: Comply with requirements in **Section 099113 "Exterior Painting"**, **Section 099123 "Interior Painting"** and **Section 099600 "High-Performance Coatings"** for cleaning and touchup painting of field welds, bolted connections, and abraded areas of shop paint on miscellaneous metal.
- C. Galvanized Surfaces: Clean welds, bolted connections, and abraded areas and apply galvanizing-repair paint to comply with ASTM A 780.

3.6 PAYMENT

- A. Lump sum price for Electrical Construction – Lighting Complete covers all items of work in this Special Provision including furnishing labor, materials, tools, equipment, and incidentals required to complete the work.

END OF SECTION

State Road and Tollway Authority (SRTA), State of Georgia

SPECIAL PROVISION

Section 999 – Electrical Construction – Lighting Complete

Section 260553 – Identification for Electrical Systems

PART 1 - GENERAL

1.1 RELATED DOCUMENTS

- A. Drawings and general provisions of the Contract, including General and Supplementary Conditions and Division 01 Specification Sections, apply to this Section.

1.2 SUMMARY

- A. Section Includes:
 1. Color and legend requirements for raceways, conductors, and warning labels and signs.
 2. Labels.
 3. Bands and tubes.
 4. Tapes and stencils.
 5. Tags.
 6. Signs.
 7. Cable ties.
 8. Paint for identification.
 9. Fasteners for labels and signs.

1.3 ACTION SUBMITTALS

- A. **Product Data:** For each type of product.
 1. Include construction details, material descriptions, dimensions of individual components and profiles, and finishes for electrical identification products.
- B. **Samples:** For each type of label and sign to illustrate composition, size, colors, lettering style, mounting provisions, and graphic features of identification products.
- C. **Identification Schedule:** For each piece of electrical equipment and electrical system components to be an index of nomenclature for electrical equipment and system components used in identification signs and labels. Use same designations indicated on Drawings.
- D. **Delegated-Design Submittal:** For arc-flash hazard study.

PART 2 - PRODUCTS

2.1 PERFORMANCE REQUIREMENTS

- A. Comply with ASME A13.1 and IEEE C2.
- B. Comply with NFPA 70.
- C. Comply with 29 CFR 1910.144 and 29 CFR 1910.145.
- D. Comply with ANSI Z535.4 for safety signs and labels.
- E. Comply with NFPA 70E requirements for arc-flash warning labels.
- F. Adhesive-attached labeling materials, including label stocks, laminating adhesives, and inks used by label printers, shall comply with UL 969.
- G. Thermal Movements: Allow for thermal movements from ambient and surface temperature changes.
 - 1. Temperature Change: 120 deg F, ambient; 180 deg F, material.

2.2 COLOR AND LEGEND REQUIREMENTS

- A. Raceways and Cables Carrying Circuits at 600 V or Less:
 - 1. Black letters on an orange field.
 - 2. Legend: Indicate voltage and system or service type.
- B. Color-Coding for Phase- and Voltage-Level Identification, 600 V or Less: Use colors listed below for ungrounded service feeder and branch-circuit conductors.
 - 1. Color shall be factory applied or field applied for sizes larger than No. 8 AWG if authorities having jurisdiction permit.
 - 2. Colors for 208/120-V Circuits:
 - a. Phase A: Black.
 - b. Phase B: Red.
 - c. Phase C: Blue.
 - 3. Colors for 240-V Circuits:
 - a. Phase A: Black.
 - b. Phase B: Red.
 - 4. Colors for 480/277-V Circuits:
 - a. Phase A: Brown.
 - b. Phase B: Orange.
 - c. Phase C: Yellow.
 - 5. Color for Neutral: White or gray

6. Color for Equipment Grounds: Green.
 7. Colors for Isolated Grounds: Green with white stripe.
- C. Warning Label Colors:
1. Identify system voltage with black letters on an orange background.
- D. Warning labels and signs shall include, but are not limited to, the following legends:
1. Multiple Power Source Warning: "DANGER - ELECTRICAL SHOCK HAZARD - EQUIPMENT HAS MULTIPLE POWER SOURCES."
 2. Workspace Clearance Warning: "WARNING - OSHA REGULATION - AREA IN FRONT OF ELECTRICAL EQUIPMENT MUST BE KEPT CLEAR FOR 36 INCHES."
- E. Equipment Identification Labels:
1. Black letters on a white field.

2.3 LABELS

- A. Vinyl Wraparound Labels: Preprinted, flexible labels laminated with a clear, weather- and chemical-resistant coating and matching wraparound clear adhesive tape for securing label ends.
- B. Snap-around Labels: Slit, pretensioned, flexible, preprinted, color-coded acrylic sleeves, with diameters sized to suit diameters and that stay in place by gripping action.
- C. Self-Adhesive Wraparound Labels: Preprinted, 3-mil-thick, polyester flexible label with acrylic pressure-sensitive adhesive.
1. Self-Lamination: Clear; UV-, weather- and chemical-resistant; self-laminating, protective shield over the legend. Labels sized such that the clear shield overlaps the entire printed legend.
 2. Marker for Labels: Permanent, waterproof, black ink marker recommended by tag manufacturer.
 3. Marker for Labels: Machine-printed, permanent, waterproof, black ink recommended by printer manufacturer.
- D. Self-Adhesive Labels: Polyester, thermal, transfer-printed, 3-mil-thick, multicolor, weather- and UV-resistant, pressure-sensitive adhesive labels, configured for intended use and location.
1. Minimum Nominal Size:
 - a. 1-1/2 by 6 inches for raceway and conductors.
 - b. 3-1/2 by 5 inches for equipment.
 - c. As required by authorities having jurisdiction.

2.4 BANDS AND TUBES

- A. Snap-around, Color-Coding Bands: Slit, pretensioned, flexible, solid-colored acrylic sleeves, 2 inches long, with diameters sized to suit diameters and that stay in place by gripping action.

- B. Heat-Shrink Preprinted Tubes: Flame-retardant polyolefin tubes with machine-printed identification labels, sized to suit diameter and shrunk to fit firmly. Full shrink recovery occurs at a maximum of 200 deg F. Comply with UL 224.

2.5 TAPES AND STENCILS

- A. Marker Tapes: Vinyl or vinyl-cloth, self-adhesive wraparound type, with circuit identification legend machine printed by thermal transfer or equivalent process.
- B. Self-Adhesive Vinyl Tape: Colored, heavy duty, waterproof, fade resistant; not less than 3 mils thick by 1 to 2 inches wide; compounded for outdoor use.
- C. Tape and Stencil: 4-inch-wide black stripes on 10-inch centers placed diagonally over orange background and is 12 inches wide. Stop stripes at legends.
- D. Floor Marking Tape: 2-inch-wide, 5-mil pressure-sensitive vinyl tape, with black and white stripes and clear vinyl overlay.
- E. Underground-Line Warning Tape:
 1. Tape:
 - a. Recommended by manufacturer for the method of installation and suitable to identify and locate underground electrical and communications utility lines.
 - b. Printing on tape shall be permanent and shall not be damaged by burial operations.
 - c. Tape material and ink shall be chemically inert and not subject to degradation when exposed to acids, alkalis, and other destructive substances commonly found in soils.
 2. Color and Printing:
 - a. Comply with ANSI Z535.1, ANSI Z535.2, ANSI Z535.3, ANSI Z535.4, and ANSI Z535.5.
 - b. Inscriptions for Red-Colored Tapes: "ELECTRIC LINE, HIGH VOLTAGE".
 - c. Inscriptions for Orange-Colored Tapes: "TELEPHONE CABLE, CATV CABLE, COMMUNICATIONS CABLE, OPTICAL FIBER CABLE".
 3. Tag:
 - a. Pigmented polyolefin, bright colored, continuous-printed on one side with the inscription of the utility, compounded for direct-burial service.
 - b. Width: 3 inches.
 - c. Thickness: 4 mils.
 - d. Weight: 18.5 lb/1000 sq. ft..
 - e. Tensile according to ASTM D 882: 30 lbf and 2500 psi.
 4. Tag: **Type II:**
 - a. Multilayer laminate, consisting of high-density polyethylene scrim coated with pigmented polyolefin; bright colored, continuous-printed on one side with the inscription of the utility, compounded for direct-burial service.
 - b. Width: 3 inches.

- c. Thickness: 12 mils.
 - d. Weight: 36.1 lb/1000 sq. ft..
 - e. Tensile according to ASTM D 882: 400 lbf and 11,500 psi.
5. Tag: **Type ID:**
- a. Detectable three-layer laminate, consisting of a printed pigmented polyolefin film, a solid aluminum-foil core, and a clear protective film that allows inspection of the continuity of the conductive core; bright colored, continuous-printed on one side with the inscription of the utility, compounded for direct-burial service.
 - b. Width: 3 inches.
 - c. Overall Thickness: 5 mils.
 - d. Foil Core Thickness: 0.35 mil.
 - e. Weight: 28 lb/1000 sq. ft..
 - f. Tensile according to ASTM D 882: 70 lbf and 4600 psi.
6. Tag: **Type IID:**
- a. Reinforced, detectable three-layer laminate, consisting of a printed pigmented woven scrim, a solid aluminum-foil core, and a clear protective film that allows inspection of the continuity of the conductive core; bright-colored, continuous-printed on one side with the inscription of the utility, compounded for direct-burial service.
 - b. Width: 3 inches.
 - c. Overall Thickness: 8 mils
 - d. Foil Core Thickness: 0.35 mil.
 - e. Weight: 34 lb/1000 sq. ft..
 - f. Tensile according to ASTM D 882: 300 lbf and 12,500 psi.
- F. Stenciled Legend: In nonfading, waterproof, black ink or paint. Minimum letter height shall be **1 inch**.

2.6 TAGS

- A. Metal Tags: Brass or aluminum, 2 by 2 by 0.05 inch, with stamped legend, punched for use with self-locking cable tie fastener.
- B. Nonmetallic Preprinted Tags: Polyethylene tags, 0.015-inch thick, color-coded for phase and voltage level, with factory printed permanent designations; punched for use with self-locking cable tie fastener.
- C. Write-on Tags:
 - 1. Polyester Tags: 0.010-inch thick, with corrosion-resistant grommet and cable tie for attachment.
 - 2. Marker for Tags: Permanent, waterproof, black ink marker recommended by tag manufacturer.
 - 3. Marker for Tags: Machine-printed, permanent, waterproof, black ink marker recommended by printer manufacturer.

2.7 SIGNS

A. Baked-Enamel Signs:

1. Preprinted aluminum signs, high-intensity reflective, punched or drilled for fasteners, with colors, legend, and size required for application.
2. 1/4-inch grommets in corners for mounting.
3. Nominal Size: 7 by 10 inches.

B. Metal-Backed Butyrate Signs:

1. Weather-resistant, nonfading, preprinted, cellulose-acetate butyrate signs, with 0.0396-inch galvanized-steel backing, punched and drilled for fasteners, and with colors, legend, and size required for application.
2. 1/4-inch grommets in corners for mounting.
3. Nominal Size: 10 by 14 inches.

C. Laminated Acrylic or Melamine Plastic Signs:

1. Engraved legend.
2. Thickness:
 - a. For signs up to 20 sq. in., minimum 1/16 inch thick.
 - b. For signs larger than 20 sq. in., 1/8 inch thick.
 - c. Engraved legend with black letters on white face.
 - d. Self-adhesive.
 - e. Framed with mitered acrylic molding and arranged for attachment at applicable equipment.

2.8 CABLE TIES

A. General-Purpose Cable Ties: Fungus inert, self-extinguishing, one piece, self-locking, and Type 6/6 nylon.

1. Minimum Width: 3/16 inch.
2. Tensile Strength at 73 Deg F according to ASTM D 638: 12,000 psi.
3. Temperature Range: Minus 40 to plus 185 deg F.
4. Color: Black, except where used for color-coding.

B. UV-Stabilized Cable Ties: Fungus inert, designed for continuous exposure to exterior sunlight, self-extinguishing, one piece, self-locking, and Type 6/6 nylon.

1. Minimum Width: 3/16 inch.
2. Tensile Strength at 73 Deg F according to ASTM D 638: 12,000 psi.
3. Temperature Range: Minus 40 to plus 185 deg F.
4. Color: Black.

2.9 MISCELLANEOUS IDENTIFICATION PRODUCTS

- A. **Paint:** Comply with requirements in painting Sections for paint materials and application requirements. Retain paint system applicable for surface material and location (exterior or interior).
- B. **Fasteners for Labels and Signs:** Self-tapping, stainless-steel screws or stainless-steel machine screws with nuts and flat and lock washers.

PART 3 - EXECUTION

3.1 PREPARATION

- A. **Self-Adhesive Identification Products:** Before applying electrical identification products, clean substrates of substances that could impair bond, using materials and methods recommended by manufacturer of identification product.

3.2 INSTALLATION

- A. Verify and coordinate identification names, abbreviations, colors, and other features with requirements in other Sections requiring identification applications, Drawings, Shop Drawings, manufacturer's wiring diagrams, and operation and maintenance manual. Use consistent designations throughout Project.
- B. Install identifying devices before installing acoustical ceilings and similar concealment.
- C. Verify identity of each item before installing identification products.
- D. Coordinate identification with Project Drawings, manufacturer's wiring diagrams, and operation and maintenance manual.
- E. Apply identification devices to surfaces that require finish after completing finish work.
- F. Install signs with approved legend to facilitate proper identification, operation, and maintenance of electrical systems and connected items.
- G. **System Identification for Raceways and Cables under 600 V:** Identification shall completely encircle cable or conduit. Place identification of two-color markings in contact, side by side.
 - 1. Secure tight to surface of conductor, cable, or raceway.
- H. **Auxiliary Electrical Systems Conductor Identification:** Identify field-installed alarm, control, and signal connections.
- I. **Elevated Components:** Increase sizes of labels, signs, and letters to those appropriate for viewing from the floor.
- J. **Accessible Fittings for Raceways:** Identify the covers of each junction and pull box of the following systems with the wiring system legend and system voltage. System legends shall be as follows:

1. "EMERGENCY POWER."
2. "POWER."
3. "UPS."

K. Vinyl Wraparound Labels:

1. Secure tight to surface of raceway or cable at a location with high visibility and accessibility.
2. Attach labels that are not self-adhesive type with clear vinyl tape, with adhesive appropriate to the location and substrate.

L. Snap-around Labels: Secure tight to surface at a location with high visibility and accessibility.

M. Self-Adhesive Wraparound Labels: Secure tight to surface at a location with high visibility and accessibility.

N. Self-Adhesive Labels:

1. On each item, install unique designation label that is consistent with wiring diagrams, schedules, and operation and maintenance manual.
2. Unless otherwise indicated, provide a single line of text with 1/2-inch-high letters on 1-1/2-inch-high label; where two lines of text are required, use labels 2 inches high.

O. Snap-around Color-Coding Bands: Secure tight to surface at a location with high visibility and accessibility.

P. Heat-Shrink, Preprinted Tubes: Secure tight to surface at a location with high visibility and accessibility.

Q. Marker Tapes: Secure tight to surface at a location with high visibility and accessibility.

R. Self-Adhesive Vinyl Tape: Secure tight to surface at a location with high visibility and accessibility.

1. Field-Applied, Color-Coding Conductor Tape: Apply in half-lapped turns for a minimum distance of 6 inches where splices or taps are made. Apply last two turns of tape with no tension to prevent possible unwinding.

S. Tape and Stencil: Comply with requirements in painting Sections for surface preparation and paint application.

T. Floor Marking Tape: Apply stripes to finished surfaces following manufacturer's written instructions.

U. Underground Line Warning Tape:

1. During backfilling of trenches, install continuous underground-line warning tape directly above cable or raceway at 6 to 8 inches below finished grade. Use multiple tapes where width of multiple lines installed in a common trench **or concrete envelope** exceeds 16 inches overall.
2. Limit use of underground-line warning tape to direct-buried cables.
3. Install underground-line warning tape for direct-buried cables and cables in raceways.

V. Metal Tags:

1. Place in a location with high visibility and accessibility.
 2. Secure using general-purpose cable ties.
- W. **Nonmetallic Preprinted Tags:**
1. Place in a location with high visibility and accessibility.
 2. Secure using general-purpose cable ties.
- X. **Write-on Tags:**
1. Place in a location with high visibility and accessibility.
 2. Secure using general-purpose cable ties.
- Y. **Baked-Enamel Signs:**
1. Attach signs that are not self-adhesive type with mechanical fasteners appropriate to the location and substrate.
 2. Unless otherwise indicated, provide a single line of text with 1/2-inch-high letters on minimum 1-1/2-inch-high sign; where two lines of text are required, use signs minimum 2 inches high.
- Z. **Metal-Backed Butyrate Signs:**
1. Attach signs that are not self-adhesive type with mechanical fasteners appropriate to the location and substrate.
 2. Unless otherwise indicated, provide a single line of text with 1/2-inch- high letters on 1-1/2-inch-high sign; where two lines of text are required, use labels 2 inches high.
- AA. **Laminated Acrylic or Melamine Plastic Signs:**
1. Attach signs that are not self-adhesive type with mechanical fasteners appropriate to the location and substrate.
 2. Unless otherwise indicated, provide a single line of text with 1/2-inch- high letters on 1-1/2-inch-high sign; where two lines of text are required, use labels 2 inches high.
- BB. **Cable Ties: General purpose, for attaching tags, except as listed below:**
1. Outdoors: UV-stabilized nylon.
 2. In Spaces Handling Environmental Air: Plenum rated.

3.3 IDENTIFICATION SCHEDULE

- A. Install identification materials and devices at locations for most convenient viewing without interference with operation and maintenance of equipment. Install access doors or panels to provide view of identifying devices.
- B. Identify conductors, cables, and terminals in enclosures and at junctions, terminals, pull points, and locations of high visibility. Identify by system and circuit designation.
- C. **Accessible Fittings for Raceways and Cables within Buildings:** Identify the covers of each junction and pull box of the following systems with self-adhesive labels containing the wiring system legend and system voltage. System legends shall be as follows:

1. "EMERGENCY POWER."
 2. "POWER."
 3. "UPS."
- D. **Locations of Underground Lines:** Underground-line warning tape for power, lighting, communication, and control wiring and optical-fiber cable.
- E. **Workspace Indication:** Apply floor marking tape or tape and stencil to finished surfaces. Show working clearances in the direction of access to live parts. Workspace shall comply with NFPA 70 and 29 CFR 1926.403 unless otherwise indicated. Do not install at flush-mounted panelboards and similar equipment in finished spaces.
- F. **Instructional Signs:** Self-adhesive labels, including the color code for grounded and ungrounded conductors.
- G. **Warning Labels for Indoor Cabinets, Boxes, and Enclosures for Power and Lighting:** Self-adhesive labels.
1. Apply to exterior of door, cover, or other access.
 2. For equipment with multiple power or control sources, apply to door or cover of equipment, including, but not limited to, the following:
 - a. Power-transfer switches.
 - b. Controls with external control power connections.
- H. **Arc Flash Warning Labeling:** Self-adhesive labels.
- I. **Operating Instruction Signs:** Self-adhesive labels.
- J. **Equipment Identification Labels:**
1. **Indoor Equipment:** Self-adhesive label
 2. **Outdoor Equipment:** Laminated acrylic or melamine sign.
 3. **Equipment to Be Labeled:**
 - a. **Panelboards:** Typewritten directory of circuits in the location provided by panelboard manufacturer. Panelboard identification shall be in the form of a self-adhesive, engraved, laminated acrylic or melamine label.
 - b. **Enclosures and electrical cabinets.**
 - c. **Access doors and panels for concealed electrical items.**
 - d. **Transformers:** Label that includes tag designation indicated on Drawings for the transformer, feeder, and panelboards or equipment supplied by the secondary.
 - e. **Enclosed switches.**
 - f. **Enclosed circuit breakers.**
 - g. **Enclosed controllers.**
 - h. **Push-button stations.**
 - i. **Contactors.**
 - j. **Remote-controlled switches, dimmer modules, and control devices.**
 - k. **UPS equipment.**

3.4 PAYMENT

- A. Lump sum price for Electrical Construction – Lighting Complete covers all items of work in this Special Provision including furnishing labor, materials, tools, equipment, and incidentals required to complete the work.

END OF SECTION

State Road and Tollway Authority (SRTA), State of Georgia

SPECIAL PROVISION

Section 999 – Electrical Construction – Lighting Complete

Section 265619 – LED Exterior Lighting

PART 1 - GENERAL

1.1 RELATED DOCUMENTS

- A. Drawings and general provisions of the Contract, including General and Supplementary Conditions and Division 01 Specification Sections, apply to this Section.

1.2 SUMMARY

- A. Section Includes:
 1. Exterior solid-state luminaires that are designed for and exclusively use LED lamp technology.
 2. Luminaire supports.
 3. Luminaire-mounted photoelectric relays.
- B. Related Requirements:
 1. Section 265613 "Lighting Poles and Standards" for poles and standards used to support exterior lighting equipment.

1.3 DEFINITIONS

- A. CCT: Correlated color temperature.
- B. CRI: Color rendering index.
- C. Fixture: See "Luminaire."
- D. IP: International Protection or Ingress Protection Rating.
- E. Lumen: Measured output of lamp and luminaire, or both.
- F. Luminaire: Complete lighting unit, including lamp, reflector, and housing.

1.4 ACTION SUBMITTALS

- A. Product Data: For each type of luminaire.

1. Arrange in order of luminaire designation.
 2. Include data on features, accessories, and finishes.
 3. Include physical description and dimensions of luminaire.
 4. Lamps, include life, output (lumens, CCT, and CRI), and energy-efficiency data.
 5. Photometric data and adjustment factors based on laboratory tests, complying with IES Lighting Measurements Testing and Calculation Guides, of each luminaire type. The adjustment factors shall be for lamps and accessories identical to those indicated for the luminaire as applied in this Project.
 - a. **Manufacturer's Certified Data:** Photometric data certified by manufacturer's laboratory with a current accreditation under the NVLAP for Energy Efficient Lighting Products.
 - b. **Testing Agency Certified Data:** For indicated luminaires, photometric data certified by a qualified independent testing agency. Photometric data for remaining luminaires shall be certified by manufacturer.
 6. Wiring diagrams for power, control, and signal wiring.
 7. Photoelectric relays.
 8. Means of attaching luminaires to supports and indication that the attachment is suitable for components involved.
- B. Shop Drawings:** For nonstandard or custom luminaires.
1. Include plans, elevations, sections, and mounting and attachment details.
 2. Include details of luminaire assemblies. Indicate dimensions, weights, loads, required clearances, method of field assembly, components, and location and size of each field connection.
 3. Include diagrams for power, signal, and control wiring.
 - 4.
- C. Samples:** For each luminaire and for each color and texture indicated with factory-applied finish.
- D. Product Schedule:** For luminaires and lamps. Use same designations indicated on Drawings.
- E. Delegated-Design Submittal:** For luminaire supports.
1. Include design calculations for luminaire supports.
- 1.5 INFORMATIONAL SUBMITTALS**
- A. Coordination Drawings:** Plans, drawn to scale, on which the following items are shown and coordinated with each other, using input from installers of the items involved:
1. Luminaires.
 2. Structural members to which equipment and luminaires will be attached.
 3. Underground utilities and structures.
 4. Existing underground utilities and structures.
 5. Above-grade utilities and structures.
 6. Existing above-grade utilities and structures.
 7. Building features.
 8. Vertical and horizontal information.
- B. Qualification Data:** For testing laboratory providing photometric data for luminaires.

- C. **Product Certificates:** For each type of the following:
 1. Luminaire.
 2. Photoelectric relay.
- D. **Product Test Reports:** For each luminaire, for tests performed by manufacturer and witnessed by a qualified testing agency.
- E. Source quality-control reports.
- F. Sample warranty.

1.6 CLOSEOUT SUBMITTALS

- A. **Operation and Maintenance Data:** For luminaires and photoelectric relays to include in operation and maintenance manuals.
 1. Provide a list of all lamp types used on Project. Use ANSI and manufacturers' codes.
 2. Provide a list of all photoelectric relay types used on Project; use manufacturers' codes.

1.7 MAINTENANCE MATERIAL SUBMITTALS

- A. **Furnish extra materials that match products installed and that are packaged with protective covering for storage and identified with labels describing contents.**
 1. **Glass, Acrylic, and Plastic Lenses, Covers, and Other Optical Parts:** One for every 100 of each type and rating installed. Furnish at least one of each type.
 2. **Diffusers and Lenses:** One for every 100 of each type and rating installed. Furnish at least one of each type.
 3. **Globes and Guards:** One for every 20 of each type and rating installed. Furnish at least one of each type.

1.8 QUALITY ASSURANCE

- A. **Luminaire Photometric Data Testing Laboratory Qualifications:** Luminaire manufacturers' laboratory that is accredited under the NVLAP for Energy Efficient Lighting Products.
- B. **Luminaire Photometric Data Testing Laboratory Qualifications:** Provided by an independent agency, with the experience and capability to conduct the testing indicated, that is an NRTL as defined by OSHA in 29 CFR 1910.7, accredited under the NVLAP for Energy Efficient Lighting Products and complying with applicable IES testing standards.
- C. **Provide luminaires from a single manufacturer for each luminaire type.**
- D. **Each luminaire type shall be binned within a three-step MacAdam Ellipse to ensure color consistency among luminaires.**
- E. **Installer Qualifications:** An authorized representative who is trained and approved by manufacturer.
- F. **Mockups:** For exterior luminaires, complete with power and control connections.

1. Obtain Architect's approval of luminaires in mockups before starting installations.
2. Maintain mockups during construction in an undisturbed condition as a standard for judging the completed work.
3. Approval of mockups does not constitute approval of deviations from the Contract Documents contained in mockups unless Architect specifically approves such deviations in writing.
4. Subject to compliance with requirements, approved mockups may become part of the completed Work if undisturbed at time of Substantial Completion.

1.9 DELIVERY, STORAGE, AND HANDLING

- A. Protect finishes of exposed surfaces by applying a strippable, temporary protective covering prior to shipping.

1.10 FIELD CONDITIONS

- A. Verify existing and proposed utility structures prior to the start of work associated with luminaire installation.
- B. Mark locations of exterior luminaires for approval by Architect prior to the start of luminaire installation.

1.11 WARRANTY

- A. Warranty: Manufacturer and Installer agree to repair or replace components of luminaires that fail in materials or workmanship within specified warranty period.
 1. Failures include, but are not limited to, the following:
 - a. Structural failures, including luminaire support components.
 - b. Faulty operation of luminaires and accessories.
 - c. Deterioration of metals, metal finishes, and other materials beyond normal weathering.
 2. Warranty Period: 2 year(s) from date of Substantial Completion.

PART 2 - PRODUCTS

2.1 LUMINAIRE REQUIREMENTS

- A. Electrical Components, Devices, and Accessories: Listed and labeled as defined in NFPA 70, by a qualified testing agency, and marked for intended location and application.
- B. NRTL Compliance: Luminaires shall be listed and labeled for indicated class and division of hazard by an NRTL.
- C. FM Global Compliance: Luminaires for hazardous locations shall be listed and labeled for indicated class and division of hazard by FM Global.

- D. UL Compliance: Comply with UL 1598 and listed for wet location.
- E. Lamp base complying with ANSI C81.61 or IEC 60061-1.
- F. Bulb shape complying with ANSI C79.1.
- G. CRI of minimum 80. CCT of 4100 K.
- H. L70 lamp life of 50,000 hours.
- I. Lamps dimmable from 100 percent to 0 percent of maximum light output.
- J. Internal driver.
- K. Nominal Operating Voltage: as indicated.
- L. In-line Fusing: On the primary for each luminaire.
- M. Lamp Rating: Lamp marked for outdoor use.
- N. Source Limitations: Obtain luminaires from single source from a single manufacturer.
- O. Source Limitations: For luminaires, obtain each color, grade, finish, type, and variety of luminaire from single source with resources to provide products of consistent quality in appearance and physical properties.

2.2 LUMINAIRE TYPES

- A. Area and Site:
 1. Luminaire Shape: Round.
 2. Mounting: Pole with extruded-aluminum rectangular arm, 11 inches in length.
 3. Luminaire-Mounting Height: See Drawings
 4. Distribution: See Drawings.
 5. Diffusers and Globes: Prismatic glass.
 6. Housings:
 - a. Extruded-aluminum housing and heat sink.
 - b. Clear anodized painted finish.

2.3 MATERIALS

- A. Metal Parts: Free of burrs and sharp corners and edges.
- B. Sheet Metal Components: Corrosion-resistant aluminum. Form and support to prevent warping and sagging.
- C. Doors, Frames, and Other Internal Access: Smooth operating, free of light leakage under operating conditions, and designed to permit relamping without use of tools. Designed to prevent doors, frames, lenses, diffusers, and other components from falling accidentally during relamping and when secured in operating position. Doors shall be removable for cleaning or replacing lenses.

- D. **Diffusers and Globes:**
1. **Acrylic Diffusers:** 100 percent virgin acrylic plastic, with high resistance to yellowing and other changes due to aging, exposure to heat, and UV radiation.
 2. **Glass:** Annealed crystal glass unless otherwise indicated.
 3. **Lens Thickness:** At least 0.125 inch minimum unless otherwise indicated.
- E. **Lens and Refractor Gaskets:** Use heat- and aging-resistant resilient gaskets to seal and cushion lenses and refractors in luminaire doors.
- F. **Reflecting surfaces shall have minimum reflectance as follows unless otherwise indicated:**
1. **White Surfaces:** 85 percent.
 2. **Specular Surfaces:** 83 percent.
 3. **Diffusing Specular Surfaces:** 75 percent.
- G. **Housings:**
1. **Rigidly formed, weather- and light-tight enclosure** that will not warp, sag, or deform in use.
 2. **Provide filter/breather for enclosed luminaires.**
- H. **Factory-Applied Labels:** Comply with UL 1598. Include recommended lamps. Labels shall be located where they will be readily visible to service personnel, but not seen from normal viewing angles when lamps are in place.
1. **Label shall include the following lamp characteristics:**
 - a. **"USE ONLY"** and include specific lamp type.
 - b. **Lamp diameter, shape, size, wattage and coating.**
 - c. **CCT and CRI for all luminaires.**

2.4 FINISHES

- A. **Variations in Finishes:** Noticeable variations in same piece are unacceptable. Variations in appearance of adjoining components are acceptable if they are within the range of approved Samples and are assembled or installed to minimize contrast.
- B. **Luminaire Finish:** Manufacturer's standard paint applied to factory-assembled and -tested luminaire before shipping. Where indicated, match finish process and color of pole or support materials.
- C. **Factory-Applied Finish for Aluminum Luminaires:** Comply with NAAMM's "Metal Finishes Manual for Architectural and Metal Products" for recommendations for applying and designating finishes.
1. **Finish designations prefixed by AA** comply with the system established by the Aluminum Association for designating aluminum finishes.
 2. **Natural Satin Finish:** Provide fine, directional, medium satin polish (AA-M32); buff complying with AA-M20 requirements; and seal aluminum surfaces with clear, hard-coat wax.

3. Class I, Clear-Anodic Finish: AA-M32C22A41 (Mechanical Finish: Medium satin; Chemical Finish: Etched, medium matte; Anodic Coating: Architectural Class I, clear coating 0.018 mm or thicker) complying with AAMA 611.
4. Class I, Color-Anodic Finish: AA-M32C22A42/A44 (Mechanical Finish: Medium satin; Chemical Finish: Etched, medium matte; Anodic Coating: Architectural Class I, integrally colored or electrolytically deposited color coating 0.018 mm or thicker), complying with AAMA 611.

a. Color: See Lighting Fixture Schedule.

D. **Factory-Applied Finish for Steel Luminaires:** Comply with NAAMM's "Metal Finishes Manual for Architectural and Metal Products" for recommendations for applying and designating finishes.

1. **Surface Preparation:** Clean surfaces to comply with SSPC-SP 1, to remove dirt, oil, grease, and other contaminants that could impair paint bond. Grind welds and polish surfaces to a smooth, even finish. Remove mill scale and rust, if present, from uncoated steel, complying with SSPC-SP 5/NACE No. 1 or SSPC-SP 8.
2. **Exterior Surfaces:** Manufacturer's standard finish consisting of one or more coats of primer and two finish coats of high-gloss, high-build polyurethane enamel.
 - a. Color: As selected from manufacturer's standard catalog of colors.
 - b. Color: Match Architect's sample of manufacturer's standard color.
 - c. Color: As selected by Architect from manufacturer's full range.

2.5 LUMINAIRE SUPPORT COMPONENTS

A. Comply with requirements in Section 260529 "Hangers and Supports for Electrical Systems" for channel and angle iron supports and nonmetallic channel and angle supports.

PART 3 - EXECUTION

3.1 EXAMINATION

- A. Examine substrates, areas, and conditions, with Installer present, for compliance with requirements for installation tolerances and other conditions affecting performance of the Work.
- B. Examine roughing-in for luminaire electrical conduit to verify actual locations of conduit connections before luminaire installation.
- C. Proceed with installation only after unsatisfactory conditions have been corrected.

3.2 GENERAL INSTALLATION REQUIREMENTS

- A. Comply with NECA 1.
- B. Use fastening methods and materials selected to resist seismic forces defined for the application and approved by manufacturer.
- C. Install lamps in each luminaire.

- D. Fasten luminaire to structural support.
- E. Supports:
 - 1. Sized and rated for luminaire weight.
 - 2. Able to maintain luminaire position after cleaning and relamping.
 - 3. Support luminaires without causing deflection of finished surface.
 - 4. Luminaire-mounting devices shall be capable of supporting a horizontal force of 100 percent of luminaire weight and a vertical force of 400 percent of luminaire weight.
- F. Wiring Method: Install cables in raceways. Conceal raceways and cables.
- G. Install luminaires level, plumb, and square with finished grade unless otherwise indicated.
- H. Coordinate layout and installation of luminaires with other construction.
- I. Comply with requirements in Section 260519 "Low-Voltage Electrical Power Conductors and Cables" and Section 260533 "Raceways and Boxes for Electrical Systems" for wiring connections and wiring methods.

3.3 CORROSION PREVENTION

- A. Aluminum: Do not use in contact with earth or concrete. When in direct contact with a dissimilar metal, protect aluminum by insulating fittings or treatment.
- B. Steel Conduits: Comply with Section 260533 "Raceways and Boxes for Electrical Systems." In concrete foundations, wrap conduit with 0.010-inch-thick, pipe-wrapping plastic tape applied with a 50 percent overlap.

3.4 IDENTIFICATION

- A. Identify system components, wiring, cabling, and terminals. Comply with requirements for identification specified in Section 260553 "Identification for Electrical Systems."

3.5 FIELD QUALITY CONTROL

- A. Inspect each installed luminaire for damage. Replace damaged luminaires and components.
- B. Perform the following tests and inspections with the assistance of a factory-authorized service representative:
 - 1. Operational Test: After installing luminaires, switches, and accessories, and after electrical circuitry has been energized, test units to confirm proper operation.
 - 2. Verify operation of photoelectric controls.
- C. Illumination Tests:
 - 1. Measure light intensities at night. Use photometers with calibration referenced to NIST standards. Comply with the following IES testing guide(s):
 - a. IES LM-5.

- b. IES LM-50.
- c. IES LM-52.
- d. IES LM-64.
- e. IES LM-72.

2. **Operational Test:** After installing luminaires, switches, and accessories, and after electrical circuitry has been energized, test units to confirm proper operation.

- D. Luminaire will be considered defective if it does not pass tests and inspections.
- E. Prepare a written report of tests, inspections, observations, and verifications indicating and interpreting results. If adjustments are made to lighting system, retest to demonstrate compliance with standards.

3.6 DEMONSTRATION

- A. Train Owner's maintenance personnel to adjust, operate, and maintain luminaires and photocell relays.

3.7 ADJUSTING

- A. **Occupancy Adjustments:** When requested within 12 months of date of Substantial Completion, provide on-site assistance in adjusting the direction of aim of luminaires to suit occupied conditions. Make up to two visits to Project during other-than-normal hours for this purpose. Some of this work may be required during hours of darkness.
 - 1. During adjustment visits, inspect all luminaires. Replace lamps or luminaires that are defective.
 - 2. Parts and supplies shall be manufacturer's authorized replacement parts and supplies.
 - 3. Adjust the aim of luminaires in the presence of the Architect.

3.8 PAYMENT

- A. Lump sum price for Electrical Construction – Lighting Complete covers all items of work in this Special Provision including furnishing labor, materials, tools, equipment, and incidentals required to complete the work.

END OF SECTION

State Road and Tollway Authority (SRTA), State of Georgia

SPECIAL PROVISION

Section 999 – Electrical Construction – Lighting Complete

Section 265119 – LED Interior Lighting

PART 1 - GENERAL

1.1 RELATED DOCUMENTS

- A. Drawings and general provisions of the Contract, including General and Supplementary Conditions and Division 01 Specification Sections, apply to this Section.

1.2 SUMMARY

- A. Section Includes:
 1. Interior solid-state luminaires that use LED technology.
 2. Lighting fixture supports.

1.3 DEFINITIONS

- A. CCT: Correlated color temperature.
- B. CRI: Color Rendering Index.
- C. Fixture: See "Luminaire."
- D. IP: International Protection or Ingress Protection Rating.
- E. LED: Light-emitting diode.
- F. Lumen: Measured output of lamp and luminaire, or both.
- G. Luminaire: Complete lighting unit, including lamp, reflector, and housing.

1.4 ACTION SUBMITTALS

- A. Product Data: For each type of product.
 1. Arrange in order of luminaire designation.
 2. Include data on features, accessories, and finishes.
 3. Include physical description and dimensions of luminaires.

4. Include emergency lighting units, including batteries and chargers.
 5. Include life, output (lumens, CCT, and CRI), and energy efficiency data.
 6. Photometric data and adjustment factors based on laboratory tests, complying with IESNA Lighting Measurements Testing and Calculation Guides, of each lighting fixture type. The adjustment factors shall be for lamps and accessories identical to those indicated for the lighting fixture as applied in this Project and IES LM-80.
 - a. **Manufacturers' Certified Data:** Photometric data certified by manufacturer's laboratory with a current accreditation under the National Voluntary Laboratory Accreditation Program for Energy Efficient Lighting Products.
 - b. **Testing Agency Certified Data:** For indicated luminaires, photometric data certified by a qualified independent testing agency. Photometric data for remaining luminaires shall be certified by manufacturer.
- B. Shop Drawings:** For nonstandard or custom luminaires.
1. Include plans, elevations, sections, and mounting and attachment details.
 2. Include details of luminaire assemblies. Indicate dimensions, weights, loads, required clearances, method of field assembly, components, and location and size of each field connection.
 3. Include diagrams for power, signal, and control wiring.
- C. Product Schedule:** For luminaires and lamps.

1.5 INFORMATIONAL SUBMITTALS

- A. Coordination Drawings:** Reflected ceiling plan(s) and other details, drawn to scale, on which the following items are shown and coordinated with each other, using input from installers of the items involved:
1. Lighting luminaires.
 2. Suspended ceiling components.
 3. Partitions and millwork that penetrate the ceiling or extend to within 12 inches of the plane of the luminaires.
 4. Structural members to which luminaires will be attached.
 5. Initial access modules for acoustical tile, including size and locations.
 6. Items penetrating finished ceiling, including the following:
 - a. Other luminaires.
 - b. Air outlets and inlets.
 - c. Access panels.
- B. Qualification Data:** For testing laboratory providing photometric data for luminaires.
- C. Detailed description of equipment anchorage devices on which the certification is based and their installation requirements.**
- D. Product Certificates:** For each type of luminaire.
- E. Product Test Reports:** For each luminaire, for tests performed by manufacturer and witnessed by a qualified testing agency.
- F. Sample warranty.**

1.6 CLOSEOUT SUBMITTALS

- A. **Operation and Maintenance Data:** For luminaires and lighting systems to include in operation and maintenance manuals.
 1. Provide a list of all lamp types used on Project; use ANSI and manufacturers' codes.

1.7 MAINTENANCE MATERIAL SUBMITTALS

- A. **Furnish extra materials that match products installed and that are packaged with protective covering for storage and identified with labels describing contents.**
 1. **Diffusers and Lenses:** One for every 100 of each type and rating installed. Furnish at least one of each type.
 2. **Globes and Guards:** One for every 20 of each type and rating installed. Furnish at least one of each type.

1.8 QUALITY ASSURANCE

- A. **Luminaire Photometric Data Testing Laboratory Qualifications:** Luminaire manufacturer's laboratory that is accredited under the NVLAP for Energy Efficient Lighting Products.
- B. **Luminaire Photometric Data Testing Laboratory Qualifications:** Provided by an independent agency, with the experience and capability to conduct the testing indicated, that is an NRTL as defined by OSHA in 29 CFR 1910.7, accredited under the NVLAP for Energy Efficient Lighting Products, and complying with the applicable IES testing standards.
- C. **Provide luminaires from a single manufacturer for each luminaire type.**
- D. **Each luminaire type shall be binned within a three-step MacAdam Ellipse to ensure color consistency among luminaires.**
- E. **Mockups:** For interior lighting luminaires in room or module mockups, complete with power and control connections.
 1. Obtain Architect's approval of luminaires in mockups before starting installations.
 2. Maintain mockups during construction in an undisturbed condition as a standard for judging the completed Work.
 3. Approval of mockups does not constitute approval of deviations from the Contract Documents contained in mockups unless Architect specifically approves such deviations in writing.
 4. Subject to compliance with requirements, approved mockups may become part of the completed Work if undisturbed at time of Substantial Completion.

1.9 DELIVERY, STORAGE, AND HANDLING

- A. **Protect finishes of exposed surfaces by applying a strippable, temporary protective covering before shipping.**

1.10 WARRANTY

- A. Warranty: Manufacturer and Installer agree to repair or replace components of luminaires that fail in materials or workmanship within specified warranty period.
- B. Warranty Period: Five year(s) from date of Substantial Completion.

PART 2 - PRODUCTS

2.1 LUMINAIRE REQUIREMENTS

- A. Electrical Components, Devices, and Accessories: Listed and labeled as defined in NFPA 70, by a qualified testing agency, and marked for intended location and application.
- B. NRTL Compliance: Luminaires for hazardous locations shall be listed and labeled for indicated class and division of hazard by an NRTL.
- C. FM Global Compliance: Luminaires for hazardous locations shall be listed and labeled for indicated class and division of hazard by FM Global.
- D. Recessed Fixtures: Comply with NEMA LE 4.
- E. Bulb shape complying with ANSI C79.1.
- F. Lamp base complying with ANSI C81.61 or IEC 60061-1.
- G. CRI of minimum 80. CCT of 4100 K.
- H. Rated lamp life of 35,000 hours.
- I. Lamps dimmable from 100 percent to 0 percent of maximum light output.
- J. Internal driver.
- K. Nominal Operating Voltage: 120 V ac 240 V ac 277 V ac.
 - 1. Lens Thickness: At least 0.125 inch minimum unless otherwise indicated.
- L. Housings:
 - 1. Extruded-aluminum housing and heat sink.
 - 2. Clear anodized.

2.2 STRIP LIGHT

- A. Minimum 750 lumens. Minimum allowable efficacy of 80 lumens per watt.
- B. Integral junction box with conduit fittings.

2.3 SURFACE MOUNT, LINEAR

- A. Minimum 750 lumens. Minimum allowable efficacy of 80 lumens per watt.
- B. Integral junction box with conduit fittings.

2.4 MATERIALS

- A. Metal Parts:
 - 1. Free of burrs and sharp corners and edges.
 - 2. Sheet metal components shall be steel unless otherwise indicated.
 - 3. Form and support to prevent warping and sagging.
- B. Doors, Frames, and Other Internal Access: Smooth operating, free of light leakage under operating conditions, and designed to permit relamping without use of tools. Designed to prevent doors, frames, lenses, diffusers, and other components from falling accidentally during relamping and when secured in operating position.
- C. Diffusers and Globes:
 - 1. Tempered Fresnel glass
 - 2. Acrylic Diffusers: One hundred percent virgin acrylic plastic, with high resistance to yellowing and other changes due to aging, exposure to heat, and UV radiation.
 - 3. Glass: Annealed crystal glass unless otherwise indicated.
 - 4. Lens Thickness: At least 0.125 inch minimum unless otherwise indicated.
- D. Housings:
 - 1. Extruded-aluminum housing and heat sink.
 - 2. Clear anodized finish.
- E. Factory-Applied Labels: Comply with UL 1598. Include recommended lamps. Locate labels where they will be readily visible to service personnel, but not seen from normal viewing angles when lamps are in place.
 - 1. Label shall include the following lamp characteristics:
 - a. "USE ONLY" and include specific lamp type.
 - b. Lamp diameter, shape, size, wattage, and coating.
 - c. CCT and CRI for all luminaires.

2.5 METAL FINISHES

- A. Variations in finishes are unacceptable in the same piece. Variations in finishes of adjoining components are acceptable if they are within the range of approved Samples and if they can be and are assembled or installed to minimize contrast.

PART 3 - EXECUTION**3.1 EXAMINATION**

- A. Examine substrates, areas, and conditions, with Installer present, for compliance with requirements for installation tolerances and other conditions affecting performance of the Work.
- B. Examine roughing-in for luminaire to verify actual locations of luminaire and electrical connections before fixture installation. Proceed with installation only after unsatisfactory conditions have been corrected.

3.2 TEMPORARY LIGHTING

- A. If approved by the Architect, use selected permanent luminaires for temporary lighting. When construction is sufficiently complete, clean luminaires used for temporary lighting and install new lamps.

3.3 INSTALLATION

- A. Comply with NECA 1.
- B. Install luminaires level, plumb, and square with ceilings and walls unless otherwise indicated.
- C. Install lamps in each luminaire.
- D. Supports:
 1. Sized and rated for luminaire weight.
 2. Able to maintain luminaire position after cleaning and relamping.
 3. Provide support for luminaire without causing deflection of ceiling or wall.
 4. Luminaire mounting devices shall be capable of supporting a horizontal force of 100 percent of luminaire weight and vertical force of 400 percent of luminaire weight.

3.4 IDENTIFICATION

- A. Identify system components, wiring, cabling, and terminals. Comply with requirements for identification specified in Section 260553 "Identification for Electrical Systems."

3.5 FIELD QUALITY CONTROL

- A. Perform the following tests and inspections:
 1. Operational Test: After installing luminaires, switches, and accessories, and after electrical circuitry has been energized, test units to confirm proper operation.
 2. Test for Emergency Lighting: Interrupt power supply to demonstrate proper operation. Verify transfer from normal power to battery power and retransfer to normal.
- B. Luminaire will be considered defective if it does not pass operation tests and inspections.

- C. Prepare test and inspection reports.

3.6 PAYMENT

- A. Lump sum price for **Electrical Construction – Lighting Complete** covers all items of work in this Special Provision including furnishing labor, materials, tools, equipment, and incidentals required to complete the work.

END OF SECTION

State Road and Tollway Authority (SRTA), State of Georgia

SPECIAL PROVISION

Section 999 – Electrical Construction – Lighting Complete

Section 265613 – Lighting Poles and Standards

PART 1 - GENERAL

1.1 RELATED DOCUMENTS

- A. Drawings and general provisions of the Contract, including General and Supplementary Conditions and Division 01 Specification Sections, apply to this Section.

1.2 SUMMARY

- A. Section Includes:
 1. Poles and accessories for support of luminaires.

1.3 DEFINITIONS

- A. EPA: Equivalent projected area.
- B. Luminaire: Complete luminaire.
- C. Pole: Luminaire-supporting structure, including tower used for large-area illumination.
- D. Standard: See "Pole."

1.4 ACTION SUBMITTALS

- A. Product Data: For each pole, accessory, and luminaire-supporting and -lowering device, arranged as indicated.
 1. Include data on construction details, profiles, EPA, cable entrances, materials, dimensions, weight, rated design load, and ultimate strength of individual components.
 2. Include finishes for lighting poles and luminaire-supporting devices.
 3. Anchor bolts.
 4. Manufactured pole foundations.

B. Shop Drawings:

1. Include plans, elevations, sections, and [mounting] [and] [attachment] details.
2. Include details of equipment assemblies. Indicate dimensions, weights, loads, required clearances, method of field assembly, components, and location and size of each field connection.
3. Detail fabrication and assembly of poles and pole accessories.
4. Foundation construction details, including material descriptions, dimensions, anchor bolts, support devices, and calculations, signed and sealed by a professional engineer licensed in the state of installation.
5. Anchor bolt templates keyed to specific poles and certified by manufacturer.
6. Method and procedure of pole installation. Include manufacturer's written installations.

C. Samples: For each exposed lighting pole, standard, and luminaire-supporting device and for each color and texture specified.

1.5 INFORMATIONAL SUBMITTALS

A. Pole and Support Component Certificates: Signed by manufacturers of poles, certifying that products are designed for indicated load requirements according to AASHTO LTS-6-M and that load imposed by luminaire and attachments has been included in design. The certification shall be based on design calculations signed and sealed by a professional engineer.

B. Qualification Data: For Installer.

C. Seismic Qualification Data: For accessories, and components, from manufacturer.

1. **Basis for Certification:** Indicate whether withstand certification is based on actual test of assembled components or on calculation.
2. **Dimensioned Outline Drawings of Equipment Unit:** Identify center of gravity and locate and describe mounting and anchorage provisions.
3. **Detailed description of equipment anchorage devices** on which the certification is based and their installation requirements.

D. Material Test Reports:

1. For each foundation component, by a qualified testing agency.
2. For each pole, by a qualified testing agency.

E. Source quality-control reports.

F. Field quality-control reports.

G. Sample Warranty: Manufacturer's standard warranty.

H. Soil test reports

1.6 CLOSEOUT SUBMITTALS

A. Operation and Maintenance Data: For poles to include in emergency, operation, and maintenance manuals.

1. In addition to items specified in Section 017823 "Operation and Maintenance Data," include pole inspection and repair procedures.

1.7 MAINTENANCE MATERIAL SUBMITTALS

- A. Pole repair materials.

1.8 QUALITY ASSURANCE

- A. Testing Agency Qualifications: Qualified according to ASTM C 1093 for foundation testing.

1.9 DELIVERY, STORAGE, AND HANDLING

- A. Package aluminum poles for shipping according to ASTM B 660.
- B. Store poles on decay-resistant skids at least 12 inches above grade and vegetation. Support poles to prevent distortion and arrange to provide free air circulation.
- C. Retain factory-applied pole wrappings on metal poles until right before pole installation. Handle poles with web fabric straps.

1.10 WARRANTY

- A. Special Warranty: Manufacturer agrees to repair or replace components of pole(s) that fail in materials or workmanship; that corrode; or that fade, stain, perforate, erode, or chalk due to effects of weather or solar radiation within a specified warranty period. Manufacturer may exclude lightning damage, hail damage, vandalism, abuse, or unauthorized repairs from special warranty period.
 1. Warranty Period: Five years from date of Substantial Completion.
 2. Warranty Period for Corrosion Resistance: Five years from date of Substantial Completion.
 3. Warranty Period for Color Retention: Five years from date of Substantial Completion.

PART 2 - PRODUCTS

- A. Structural Characteristics: Comply with AASHTO LTS-6-M.
- B. Dead Load: Weight of luminaire and its horizontal and vertical supports, lowering devices, and supporting structure, applied according to AASHTO LTS-6-M.
- C. Live Load: Single load of 500 lbf distributed according to AASHTO LTS-6-M.
- D. Ice Load: Load of 3 lbf/sq. ft., applied according to AASHTO LTS-6-M for applicable areas on the Ice Load Map.
- E. Wind Load: Pressure of wind on pole and luminaire, calculated and applied according to AASHTO LTS-6-M.

- F. **Strength Analysis:** For each pole, multiply the actual EPA of luminaires and brackets by a factor of 1.1 to obtain the EPA to be used in pole selection strength analysis.
- G. **Luminaire Attachment Provisions:** Comply with luminaire manufacturers' mounting requirements. Use stainless-steel fasteners and mounting bolts unless otherwise indicated.

2.2 ALUMINUM POLES

- A. **Poles:** Seamless, extruded structural tube complying with ASTM B 221, Alloy 6063-T6, with access handhole in pole wall.
- B. **Poles:** Seamless extruded structural tube complying with ASTM B 221, Alloy 6061-T6, with access handhole in pole wall.
 - 1. **Shape:** Round, tapered.
 - 2. **Mounting Provisions:** Butt flange for bolted mounting on foundation or breakaway support.
- C. **Mast Arms:** Aluminum type, continuously welded to pole attachment plate. Material and finish same as plate.
- D. **Brackets for Luminaires:** Detachable, cantilever, without underbrace.
 - 1. **Adaptor fitting** welded to pole, allowing the bracket to be bolted to the pole-mounted adapter, then bolted together with stainless-steel bolts.
 - 2. **Cross Section:** Tapered oval, with straight tubular end section to accommodate luminaire. Match pole material and finish.
- E. **Pole-Top Tenons:** Fabricated to support luminaire or luminaires and brackets indicated, and securely fastened to pole top.
- F. **Grounding and Bonding Lugs:** Bolted 1/2-inch threaded lug, complying with requirements in Section 260526 "Grounding and Bonding for Electrical Systems," listed for attaching grounding and bonding conductors of type and size listed in that Section, and accessible through handhole.
- G. **Fasteners:** Stainless steel size and type as determined by manufacturer. Corrosion-resistant items compatible with support components.
 - 1. **Materials:** Compatible with poles and standards as well as to substrates to which poles and standards are fastened and shall not cause galvanic action at contact points.
 - 2. **Anchor Bolts, Leveling Nuts, Bolt Caps, and Washers:** Hot-dip galvanized after fabrication unless otherwise indicated.
- H. **Handhole:** Oval shaped, with minimum clear opening of 2-1/2 by 5 inches, with cover secured by stainless-steel captive screws.
- I. **Prime-Coat Finish:** Manufacturer's standard prime-coat finish ready for field painting.
- J. **Aluminum Finish:** Comply with NAAMM's "Metal Finishes Manual for Architectural and Metal Products" recommendations for applying and designating finishes.

1. Finish designations prefixed by AA comply with the system established by the Aluminum Association for designating aluminum finishes.
 2. Natural Satin Finish: Provide fine, directional, medium satin polish (AA-M32); buff complying with AA-M20 requirements; and seal aluminum surfaces with clear, hard-coat wax.
 3. Class I, Clear-Anodic Finish: AA-M32C22A41 (Mechanical Finish: Medium satin; Chemical Finish: Etched, medium matte; Anodic Coating: Architectural Class I clear coating of 0.018 mm or thicker), complying with AAMA 611.
 4. Class I, Color-Anodic Finish: AA-M32C22A42/A44 (Mechanical Finish: Medium; Chemical Finish: Etched, medium matte; Anodic Coating: Architectural Class I integrally colored or electrolytically deposited color coating 0.018 mm or thicker), complying with AAMA 611.
- K. **Factory-Painted Finish:** Comply with NAAMM's "Metal Finishes Manual for Architectural and Metal Products" recommendations for applying and designating finishes.
1. **Surface Preparation:** Clean surfaces to comply with SSPC-SP 1 to remove dirt, oil, grease, and other contaminants that could impair paint bond. Grind welds and polish surfaces to a smooth, even finish. Remove mill scale and rust, if present, from uncoated steel, according to SSPC-SP 5/NACE No. 1 or SSPC-SP 8.
 2. **Interior Surfaces of Pole:** One coat of bituminous paint, or otherwise treat for equal corrosion protection.
 3. **Exterior Surfaces:** Manufacturer's standard finish consisting of one or more coats of primer and two finish coats of high-gloss, high-build polyurethane enamel.
 - a. **Color:** As indicated by manufacturer's designations.
- L. **Powder-Coat Finish:** Comply with NAAMM's "Metal Finishes Manual for Architectural and Metal Products" recommendations for applying and designating finishes.
1. **Surface Preparation:** Clean surfaces to comply with SSPC-SP 1 to remove dirt, oil, grease, and other contaminants that could impair powder coat bond. Grind welds and polish surfaces to a smooth, even finish. Remove mill scale and rust, if present, from uncoated steel, according to SSPC-SP 5/NACE No. 1 or SSPC-SP 8.
 2. **Powder coat shall comply with AAMA 2604.**
 - a. **Electrostatic applied powder coating;** single application with a minimum 2.5- to 3.5-mils dry film thickness; cured according to manufacturer's instructions. Coat interior and exterior of pole for equal corrosion protection.
 - b. **Color:** As indicated by manufacturer's designations.

2.3 GENERAL FINISH REQUIREMENTS

- A. **Protect mechanical finishes on exposed surfaces from damage by applying a strippable, temporary protective covering before shipping.**
- B. **Appearance of Finished Work:** Noticeable variations in same piece are unacceptable. Variations in appearance of adjoining components are acceptable if they are within the range of approved Samples and are assembled or installed to minimize contrast.

PART 3 - EXECUTION

3.1 EXAMINATION

- A. Examine areas and conditions, with Installer present, for compliance with requirements for installation tolerances and other conditions affecting performance of the Work.
- B. Examine poles, luminaire-mounting devices, lowering devices, and pole accessories before installation. Components that are scratched, dented, marred, wet, moisture damaged, or visibly damaged are considered defective.
- C. Examine roughing-in for foundation and conduit to verify actual locations of installation.
- D. Proceed with installation only after unsatisfactory conditions have been corrected.

3.2 POLE FOUNDATION

- A. Concrete Pole Foundations: Cast in place, with anchor bolts to match pole-base flange. Structural steel complying with ASTM A 36/A 36M and hot-dip galvanized according to ASTM A 123/A 123 M; and with top-plate and mounting bolts to match pole-base flange and strength required to support pole, luminaire, and accessories. Concrete, reinforcement, and formwork are specified in Section 033000 "Cast-in-Place Concrete."
- B. Pre-Cast Foundations: Factory fabricated, with structural steel complying with ASTM A 36/A 36M and hot-dip galvanized according to ASTM A 123/A 123M; and with top-plate and mounting bolts to match pole-base flange and strength required to support pole, luminaire, and accessories. Concrete, reinforcement, and formwork are specified in Section 033000 "Cast-in-Place Concrete."
- C. Power-Installed Screw Foundations: Factory fabricated by pole manufacturer, with structural steel complying with ASTM A 36/A 36M and hot-dip galvanized according to ASTM A 123/A 123M; and with top-plate and mounting bolts to match pole-base flange and strength required to support pole, luminaire, and accessories.
 - 1. Baseplate: Stamped with manufacturer's name, date of production, and cable entry.
 - 2. Make holes 6 inches in diameter larger than pole diameter.
 - 3. Fill augered hole around pole with air-entrained concrete having a minimum compressive strength of 3000 psi at 28 days and finish in a dome above finished grade.
 - 4. Use a short piece of 1/2-inch diameter pipe to make a drain hole through grout. Arrange to drain condensation from interior of pole.
 - 5. Cure concrete a minimum of 72 hours before performing work on pole.
- D. Anchor Bolts: Install plumb using manufacturer-supplied steel template, uniformly spaced.

3.3 POLE INSTALLATION

- A. Alignment: Align pole foundations and poles for optimum directional alignment of luminaires and their mounting provisions on pole.

- B. Clearances: Maintain the following minimum horizontal distances of poles from surface and underground features unless otherwise indicated on drawing.
 1. Fire Hydrants and Water Piping: 60 inches.
 2. Water, Gas, Electric, Communications, and Sewer Lines: 10 feet.
 3. Trees: 15 feet from tree trunk.
- C. Foundation-Mounted Poles: Mount pole with leveling nuts and tighten top nuts to torque level according to pole manufacturer's written instructions.
 1. Use anchor bolts and nuts selected to resist seismic forces defined for the application and approved by manufacturer.
 2. Grout void between pole base and foundation. Use nonshrink or expanding concrete grout firmly packed to fill space.
 3. Install base covers unless otherwise indicated.
 4. Use a short piece of 1/2 -inch diameter pipe to make a drain hole through grout. Arrange to drain condensation from interior of pole.
- D. Poles and Pole Foundations Set in Concrete-Paved Areas: Install poles with a minimum 6-inch-wide, unpaved gap between the pole or pole foundation and the edge of the adjacent concrete slab. Fill unpaved ring with pea gravel. Insert material to a level 1 inch below top of concrete slab.
- E. Raise and set pole using web fabric slings (not chain or cable) at locations indicated by manufacturer.

3.4 CORROSION PREVENTION

- A. Aluminum: Do not use in contact with earth or concrete. When in direct contact with a dissimilar metal, protect aluminum using insulating fittings or treatment.
- B. Steel Conduits: Comply with requirements in Section 260533 "Raceways and Boxes for Electrical Systems." In concrete foundations, wrap conduit with 0.010-inch-thick, pipe-wrapping plastic tape applied with a 50-percent overlap.

3.5 GROUNDING

- A. Ground Metal Poles and Support Structures: Comply with requirements in Section 260526 "Grounding and Bonding for Electrical Systems."
 1. Install grounding electrode for each pole unless otherwise indicated.
 2. Install grounding conductor pigtail in the base for connecting luminaire to grounding system.
- B. Ground Nonmetallic Poles and Support Structures: Comply with requirements in Section 260526 "Grounding and Bonding for Electrical Systems."
 1. Install grounding electrode for each pole.
 2. Install grounding conductor and conductor protector.
 3. Ground metallic components of pole accessories and foundation.

3.6 IDENTIFICATION

- A. Identify system components, wiring, cabling, and terminals. Comply with requirements for identification specified in Section 260553 "Identification for Electrical Systems."

3.7 FIELD QUALITY CONTROL

- A. Special Inspections: Owner will engage a qualified special inspector to perform the following special inspections:
 - 1. Inspect poles for nicks, mars, dents, scratches, and other damage.
 - 2. System function tests.

3.8 PAYMENT

- A. Lump sum price for Electrical Construction – Lighting Complete covers all items of work in this Special Provision including furnishing labor, materials, tools, equipment, and incidentals required to complete the work.

END OF SECTION

State Road and Tollway Authority (SRTA), State of Georgia

SPECIAL PROVISION

Section 999 – Electrical Construction – Lighting Complete

Section 262213 – Low-Voltage Distribution Transformers

PART 1 - GENERAL

1.1 RELATED DOCUMENTS

- A. Drawings and general provisions of the Contract, including General and Supplementary Conditions and Division 01 Specification Sections, apply to this Section.

1.2 SUMMARY

- A. Section includes distribution, dry-type transformers with a nominal primary and secondary rating of 600 V and less, with capacities up to 1500 kVA.

1.3 ACTION SUBMITTALS

- A. Product Data: For each type of product.
 1. Include construction details, material descriptions, dimensions of individual components and profiles, and finishes for each type and size of transformer.
 2. Include rated nameplate data, capacities, weights, dimensions, minimum clearances, installed devices and features, and performance for each type and size of transformer.
- B. Shop Drawings:
 1. Detail equipment assemblies and indicate dimensions, weights, loads, required clearances, method of field assembly, components, and location and size of each field connection.
 2. Vibration Isolation Base Details: Detail fabrication including anchorages and attachments to structure and to supported equipment.
 3. Include diagrams for power, signal, and control wiring.

1.4 INFORMATIONAL SUBMITTALS

- A. Qualification Data: For testing agency.
- B. Source quality-control reports.
- C. Field quality-control reports.

1.5 CLOSEOUT SUBMITTALS

- A. Operation and Maintenance Data: For transformers to include in emergency, operation, and maintenance manuals.

1.6 QUALITY ASSURANCE

- A. Testing Agency Qualifications: Accredited by NETA.
 - 1. Testing Agency's Field Supervisor: Certified by NETA to supervise on-site testing.

1.7 DELIVERY, STORAGE, AND HANDLING

- A. Inspection: On receipt, inspect for and note any shipping damage to packaging and transformer.
 - 1. If manufacturer packaging is removed for inspection, and transformer will be stored after inspection, re-package transformer using original or new packaging materials that provide protection equivalent to manufacturer's packaging.
- B. Storage: Store in a warm, dry, and temperature-stable location in original shipping packaging.
- C. Temporary Heating: Apply temporary heat according to manufacturer's written instructions within the enclosure of each ventilated-type unit, throughout periods during which equipment is not energized and when transformer is not in a space that is continuously under normal control of temperature and humidity.
- D. Handling: Follow manufacturer's instructions for lifting and transporting transformers.

PART 2 - PRODUCTS

2.1 MANUFACTURERS

- A. 1. Schneider Electric (Square D) 2. General Electric GE 3. Siemens
- B. Source Limitations: Obtain each transformer type from single source from single manufacturer.

2.2 GENERAL TRANSFORMER REQUIREMENTS

- A. Description: Factory-assembled and -tested, air-cooled units for 60-Hz service.
- B. Comply with NFPA 70.
 - 1. Electrical Components, Devices, and Accessories: Listed and labeled as defined in NFPA 70, by a qualified testing agency, and marked for intended location and use.
- C. Transformers Rated 15 kVA and Larger:
 - 1. Comply with 10 CFR 431 (DOE 2016) efficiency levels.
 - 2. Marked as compliant with DOE 2016 efficiency levels by an NRTL.

- D. **Shipping Restraints:** Paint or otherwise color-code bolts, wedges, blocks, and other restraints that are to be removed after installation and before energizing. Use fluorescent colors that are easily identifiable inside the transformer enclosure.

2.3 DISTRIBUTION TRANSFORMERS

- A. Comply with NFPA 70.
- B. **Cores:** Electrical grade, non-aging silicon steel with high permeability and low hysteresis losses.
 1. One leg per phase.
 2. Core volume shall allow efficient transformer operation at 10 percent above the nominal tap voltage.
 3. Grounded to enclosure.
- C. **Coils:** Continuous windings without splices except for taps.
 1. Coil Material: Copper.
 2. Internal Coil Connections: Brazed or pressure type.
 3. Terminal Connections: Welded.
- D. **Encapsulation:** Transformers smaller than 30 kVA shall have core and coils completely resin encapsulated.
- E. **Enclosure:** Ventilated.
 1. NEMA 250, Type 2: Core and coil shall be encapsulated within resin compound using a vacuum-pressure impregnation process to seal out moisture and air.
 2. KVA Ratings: Based on convection cooling only and not relying on auxiliary fans.
 3. Wiring Compartment: Sized for conduit entry and wiring installation.
 4. Finish: Comply with NEMA 250.
 - a. Finish Color: Gray weather-resistant enamel.
- F. **Taps for Transformers 3 kVA and Smaller:** None.
- G. **Taps for Transformers 7.5 to 24 kVA:** One 5 percent tap above and one 5 percent tap below normal full capacity.
- H. **Taps for Transformers 25 kVA and Larger:** Two 2.5 percent taps above and two 2.5 percent taps below normal full capacity
- I. **Insulation Class, Smaller Than 30 kVA:** 180 deg C, UL-component-recognized insulation system with a maximum of 115 deg C rise above 40 deg C ambient temperature.
- J. **Insulation Class, 30 kVA and Larger:** 220 deg C, UL-component-recognized insulation system with a maximum of 150 deg C rise above 40 deg C ambient temperature.
- K. **Grounding:** Provide ground-bar kit or a ground bar installed on the inside of the transformer enclosure.
 - 1.

- L. **Electrostatic Shielding:** Each winding shall have an independent, single, full-width copper electrostatic shield arranged to minimize interwinding capacitance.
 - 1. Arrange coil leads and terminal strips to minimize capacitive coupling between input and output terminals.
 - 2. Include special terminal for grounding the shield.
- M. **Low-Sound-Level Requirements:** Maximum sound levels when factory tested according to IEEE C57.12.91, as follows:
 - 1. 9.00 kVA and Less: 40 dBA.
 - 2. 9.01 to 30.00 kVA: 45 dBA.
 - 3. 30.01 to 50.00 kVA: 45 dBA for K-factors of 1, 4, and 9.
 - 4. 50.01 to 150.00 kVA: 50 dBA for K-factors of 1, 4, and 9.

2.4 IDENTIFICATION

- A. **Nameplates:** Engraved, laminated-acrylic or melamine plastic signs for each distribution transformer, mounted with corrosion-resistant screws. Nameplates and label products are specified in Section 260553 "Identification for Electrical Systems."
- B. **Nameplates:** Self-adhesive label for each distribution transformer. Self-adhesive labels are specified in Section 260553 "Identification for Electrical Systems."

2.5 SOURCE QUALITY CONTROL

- A. **Test and inspect transformers according to IEEE C57.12.01 and IEEE C57.12.91.**
 - 1. Resistance measurements of all windings at rated voltage connections and at all tap connections.
 - 2. Ratio tests at rated voltage connections and at all tap connections.
 - 3. Phase relation and polarity tests at rated voltage connections.
 - 4. No load losses, and excitation current and rated voltage at rated voltage connections.
 - 5. Impedance and load losses at rated current and rated frequency at rated voltage connections.
 - 6. Applied and induced tensile tests.
 - 7. Regulation and efficiency at rated load and voltage.
 - 8. **Insulation-Resistance Tests:**
 - a. High-voltage to ground.
 - b. Low-voltage to ground.
 - c. High-voltage to low-voltage.
 - 9. Temperature tests.
- B. **Factory Sound-Level Tests:** Conduct sound-level tests on equipment for this Project.

PART 3 - EXECUTION

3.1 EXAMINATION

- A. Examine conditions for compliance with enclosure- and ambient-temperature requirements for each transformer.
- B. Verify that field measurements are as needed to maintain working clearances required by NFPA 70 and manufacturer's written instructions.
- C. Examine walls, floors, roofs, and concrete bases for suitable mounting conditions where transformers will be installed.
- D. Verify that ground connections are in place and requirements in Section 260526 "Grounding and Bonding for Electrical Systems" have been met. Maximum ground resistance shall be 5 ohms at location of transformer.
- E. Environment: Enclosures shall be rated for the environment in which they are located. Covers for NEMA 250, Type 4X enclosures shall not cause accessibility problems.
- F. Proceed with installation only after unsatisfactory conditions have been corrected.

3.2 INSTALLATION

- A. Install wall-mounted transformers level and plumb with wall brackets fabricated by transformer manufacturer.
 - 1. Coordinate installation of wall-mounted and structure-hanging supports with actual transformer provided.
 - 2. Brace wall-mounted transformers as specified in Section 260548.16 "Seismic Controls for Electrical Systems."
- B. Install transformers level and plumb on a concrete base with vibration-dampening supports. Locate transformers away from corners and not parallel to adjacent wall surface.
- C. Construct concrete bases according to Section 033000 "Cast-in-Place Concrete" or Section 033053 "Miscellaneous Cast-in-Place Concrete" and anchor floor-mounted transformers according to manufacturer's written instructions and requirements in Section 260529 "Hangers and Supports for Electrical Systems."
 - 1. Coordinate size and location of concrete bases with actual transformer provided. Cast anchor-bolt inserts into bases. Concrete, reinforcement, and formwork requirements are specified with concrete.
- D. Secure transformer to concrete base according to manufacturer's written instructions.
- E. Secure covers to enclosure and tighten all bolts to manufacturer-recommended torques to reduce noise generation.
- F. Remove shipping bolts, blocking, and wedges.

3.3 CONNECTIONS

- A. Ground equipment according to Section 260526 "Grounding and Bonding for Electrical Systems."
- B. Connect wiring according to Section 260519 "Low-Voltage Electrical Power Conductors and Cables."
- C. Tighten electrical connectors and terminals according to manufacturer's published torque-tightening values. If manufacturer's torque values are not indicated, use those specified in UL 486A-486B.
- D. Provide flexible connections at all conduit and conductor terminations and supports to eliminate sound and vibration transmission to the building structure.

3.4 FIELD QUALITY CONTROL

- A. Testing Agency: Owner will engage a qualified testing agency to perform tests and inspections.
- B. Testing Agency: Engage a qualified testing agency to perform tests and inspections.
- C. Manufacturer's Field Service: Engage a factory-authorized service representative to test and inspect components, assemblies, and equipment installations, including connections.
- D. Perform tests and inspections with the assistance of a factory-authorized service representative.
- E. Small (Up to 167-kVA Single-Phase or 500-kVA Three-Phase) Dry-Type Transformer Field Tests:
 - 1. Visual and Mechanical Inspection.
 - a. Inspect physical and mechanical condition.
 - b. Inspect anchorage, alignment, and grounding.
 - c. Verify that resilient mounts are free and that any shipping brackets have been removed.
 - d. Verify the unit is clean.
 - e. Perform specific inspections and mechanical tests recommended by manufacturer.
 - f. Verify that as-left tap connections are as specified.
 - g. Verify the presence of surge arresters and that their ratings are as specified.
 - 2. Electrical Tests:
 - a. Measure resistance at each winding, tap, and bolted connection.
 - b. Perform insulation-resistance tests winding-to-winding and each winding-to-ground. Apply voltage according to manufacturer's published data. In the absence of manufacturer's published data, comply with NETA ATS, Table 100.5. Calculate polarization index: the value of the index shall not be less than 1.0.
 - c. Perform turns-ratio tests at all tap positions. Test results shall not deviate by more than one-half percent from either the adjacent coils or the calculated ratio. If test fails, replace the transformer.
 - d. Verify correct secondary voltage, phase-to-phase and phase-to-neutral, after energization and prior to loading.

- F. **Large (Larger Than 167-kVA Single Phase or 500-kVA Three Phase) Dry-Type Transformer Field Tests:**
1. **Visual and Mechanical Inspection:**
 - a. Inspect physical and mechanical condition.
 - b. Inspect anchorage, alignment, and grounding.
 - c. Verify that resilient mounts are free and that any shipping brackets have been removed.
 - d. Verify the unit is clean.
 - e. Perform specific inspections and mechanical tests recommended by manufacturer.
 - f. Verify that as-left tap connections are as specified.
 - g. Verify the presence of surge arresters and that their ratings are as specified.
 2. **Electrical Tests:**
 - a. Measure resistance at each winding, tap, and bolted connection.
 - b. Perform insulation-resistance tests winding-to-winding and each winding-to-ground. Apply voltage according to manufacturer's published data. In the absence of manufacturer's published data, comply with NETA ATS, Table 100.5. Calculate polarization index: the value of the index shall not be less than 1.0.
 - c. Perform power-factor or dissipation-factor tests on all windings.
 - d. Perform turns-ratio tests at all tap positions. Test results shall not deviate by more than one-half percent from either the adjacent coils or the calculated ratio. If test fails, replace the transformer.
 - e. Perform an excitation-current test on each phase.
 - f. Perform an applied voltage test on all high- and low-voltage windings to ground. See IEEE C57.12.91, Sections 10.2 and 10.9.
 - g. Verify correct secondary voltage, phase-to-phase and phase-to-neutral, after energization and prior to loading.
- G. Remove and replace units that do not pass tests or inspections and retest as specified above.
- H. **Infrared Scanning: Two months after Substantial Completion, perform an infrared scan of transformer connections.**
1. Use an infrared-scanning device designed to measure temperature or detect significant deviations from normal values. Provide documentation of device calibration.
 2. Perform two follow-up infrared scans of transformers, one at four months and the other at 11 months after Substantial Completion.
 3. Prepare a certified report identifying transformer checked and describing results of scanning. Include notation of deficiencies detected, remedial action taken, and scanning observations after remedial action.
- I. **Test Labeling: On completion of satisfactory testing of each unit, attach a dated and signed "Satisfactory Test" label to tested component.**

3.5 ADJUSTING

- A. Record transformer secondary voltage at each unit for at least 48 hours of typical occupancy period. Adjust transformer taps to provide optimum voltage conditions at secondary terminals. Optimum is defined as not exceeding nameplate voltage plus 5 percent and not being lower

than nameplate voltage minus 3 percent at maximum load conditions. Submit recording and tap settings as test results.

- B. **Output Settings Report:** Prepare a written report recording output voltages and tap settings.

3.6 CLEANING

- A. Vacuum dirt and debris; do not use compressed air to assist in cleaning.

3.7 PAYMENT

- A. Lump sum price for **Electrical Construction – Lighting Complete** covers all items of work in this **Special Provision** including furnishing labor, materials, tools, equipment, and incidentals required to complete the work.

END OF SECTION

State Road and Tollway Authority (SRTA), State of Georgia

SPECIAL PROVISION

Section 999 – Electrical Construction – Lighting Complete

Section 260519 – Low-Voltage Electrical Power Conductors & Cables

PART 1 - GENERAL

1.1 RELATED DOCUMENTS

- A. Drawings and general provisions of the Contract, including General and Supplementary Conditions and Division 01 Specification Sections, apply to this Section.

1.2 SUMMARY

- A. Section Includes:
 1. Copper building wire rated 600 V or less.
 2. Connectors, splices, and terminations rated 600 V and less.

1.3 ACTION SUBMITTALS

- A. Product Data: For each type of product.
- B. Product Schedule: Indicate type, use, location, and termination locations.

1.4 INFORMATIONAL SUBMITTALS

- A. Field quality-control reports.

1.5 QUALITY ASSURANCE

- A. Testing Agency Qualifications: Member company of NETA.
 1. Testing Agency's Field Supervisor: Certified by NETA to supervise on-site testing.

PART 2 - PRODUCTS**2.1 COPPER BUILDING WIRE**

- A. Description: Flexible, insulated and uninsulated, drawn copper current-carrying conductor with an overall insulation layer or jacket, or both, rated 600 V or less.
- B. 1. Southwire Company 2. Republic Wire Inc. 3. USA Wire and Cable Inc.
- C. Standards:
 - 1. Listed and labeled as defined in NFPA 70, by a qualified testing agency, and marked for intended location and use.
 - 2. RoHS compliant.
 - 3. Conductor and Cable Marking: Comply with wire and cable marking according to UL's "Wire and Cable Marking and Application Guide."
- D. Conductors: Copper, complying with ASTM B 3 for bare annealed copper and with ASTM B 8 for stranded conductors.
- E. Conductor Insulation:
 - 1. Type THHN and Type THWN-2: Comply with UL 83.

2.2 CONNECTORS AND SPLICES

- A. Description: Factory-fabricated connectors, splices, and lugs of size, ampacity rating, material, type, and class for application and service indicated; listed and labeled as defined in NFPA 70, by a qualified testing agency, and marked for intended location and use.
- B. Lugs: One piece, seamless, designed to terminate conductors specified in this Section.
 - 1. Material: Copper.
 - 2. Type: One hole with standard barrels.
 - 3. Termination: Compression.

PART 3 - EXECUTION**3.1 CONDUCTOR MATERIAL APPLICATIONS**

- A. Feeders: Copper; solid for No. 10 AWG and smaller; stranded for No. 8 AWG and larger.
- B. Feeders: Copper for feeders smaller than No. 4 AWG; copper or aluminum for feeders No. 4 AWG and larger. Conductors shall be solid for No. 10 AWG and smaller; stranded for No. 8 AWG and larger.
- C. Branch Circuits: Copper. Solid for No. 10 AWG and smaller; stranded for No. 8 AWG and larger.
- D. Branch Circuits: Copper. Solid for No. 12 AWG and smaller; stranded for No. 10 AWG and larger.

3.2 CONDUCTOR INSULATION AND MULTICONDUCTOR CABLE APPLICATIONS AND WIRING METHODS

- A. Service Entrance: Type THHN/THWN-2, single conductors in raceway.
- B. Exposed Feeders: Type THHN/THWN-2, single conductors in raceway.
- C. Feeders Concealed in Ceilings, Walls, Partitions, and Crawlspace: Type THHN/THWN-2, single conductors in raceway.
- D. Feeders Concealed in Concrete, below Slabs-on-Grade, and Underground: Type THHN/THWN-2, single conductors in raceway.
- E. Branch Circuits Concealed in Ceilings, Walls, and Partitions: Type THHN/THWN-2, single conductors in raceway.
- F. Branch Circuits Concealed in Concrete, below Slabs-on-Grade, and Underground: Type THHN/THWN-2, single conductors in raceway.

3.3 INSTALLATION OF CONDUCTORS AND CABLES

- A. Conceal cables in finished walls, ceilings, and floors unless otherwise indicated.
- B. Complete raceway installation between conductor and cable termination points according to Section 260533 "Raceways and Boxes for Electrical Systems" prior to pulling conductors and cables.
- C. Use manufacturer-approved pulling compound or lubricant where necessary; compound used must not deteriorate conductor or insulation. Do not exceed manufacturer's recommended maximum pulling tensions and sidewall pressure values.
- D. Use pulling means, including fish tape, cable, rope, and basket-weave wire/cable grips, that will not damage cables or raceway.
- E. Install exposed cables parallel and perpendicular to surfaces of exposed structural members, and follow surface contours where possible.
- F. Support cables according to Section 260529 "Hangers and Supports for Electrical Systems."
- G. Complete cable tray systems installation according to Section 260536 "Cable Trays for Electrical Systems" prior to installing conductors and cables.

3.4 CONNECTIONS

- A. Tighten electrical connectors and terminals according to manufacturer's published torque-tightening values. If manufacturer's torque values are not indicated, use those specified in UL 486A-486B.
- B. Make splices, terminations, and taps that are compatible with conductor material and that possess equivalent or better mechanical strength and insulation ratings than unspliced conductors.

- C. **Wiring at Outlets:** Install conductor at each outlet, with at least 6 inches of slack.

3.5 IDENTIFICATION

- A. **Identify and color-code conductors and cables** according to Section 260553 "Identification for Electrical Systems."
- B. **Identify each spare conductor at each end with identity number and location of other end of conductor, and identify as spare conductor.**

3.6 SLEEVE AND SLEEVE-SEAL INSTALLATION FOR ELECTRICAL PENETRATIONS

- A. **Install sleeves and sleeve seals at penetrations of exterior floor and wall assemblies. Comply with requirements in Section 260544 "Sleeves and Sleeve Seals for Electrical Raceways and Cabling."**

3.7 FIRESTOPPING

- A. **Apply firestopping to electrical penetrations of fire-rated floor and wall assemblies to restore original fire-resistance rating of assembly according to Section 078413 "Penetration Firestopping."**

3.8 FIELD QUALITY CONTROL

- A. **Testing Agency: Owner will engage a qualified testing agency to perform tests and inspections.**
- B. **Testing Agency: Engage a qualified testing agency to perform tests and inspections.**
- C. **Manufacturer's Field Service: Engage a factory-authorized service representative to test and inspect components, assemblies, and equipment installations, including connections.**
- D. **Perform tests and inspections with the assistance of a factory-authorized service representative.**
 - 1. **After installing conductors and cables and before electrical circuitry has been energized, test service entrance and feeder conductors for compliance with requirements.**
 - 2. **After installing conductors and cables and before electrical circuitry has been energized, test service entrance and feeder conductors and conductors feeding the following critical equipment and services for compliance with requirements:**
 - 3. **Perform each of the following visual and electrical tests:**
 - a. **Inspect exposed sections of conductor and cable for physical damage and correct connection according to the single-line diagram.**
 - b. **Test bolted connections for high resistance using one of the following:**
 - 1) A low-resistance ohmmeter.
 - 2) Calibrated torque wrench.
 - 3) Thermographic survey.
 - c. **Inspect compression-applied connectors for correct cable match and indentation.**

- d. Inspect for correct identification.
 - e. Inspect cable jacket and condition.
 - f. Insulation-resistance test on each conductor for ground and adjacent conductors. Apply a potential of 500-V dc for 300-V rated cable and 1000-V dc for 600-V rated cable for a one-minute duration.
 - g. Continuity test on each conductor and cable.
 - h. Uniform resistance of parallel conductors.
4. **Initial Infrared Scanning:** After Substantial Completion, but before Final Acceptance, perform an infrared scan of each splice in conductors No. 3 AWG and larger. Remove box and equipment covers so splices are accessible to portable scanner. Correct deficiencies determined during the scan.
- a. **Instrument:** Use an infrared scanning device designed to measure temperature or to detect significant deviations from normal values. Provide calibration record for device.
 - b. **Record of Infrared Scanning:** Prepare a certified report that identifies switches checked and that describes scanning results. Include notation of deficiencies detected, remedial action taken, and observations after remedial action.
5. **Follow-up Infrared Scanning:** Perform an additional follow-up infrared scan of each switch 11 months after date of Substantial Completion.
- E. Cables will be considered defective if they do not pass tests and inspections.
- F. Prepare test and inspection reports to record the following:
- 1. Procedures used.
 - 2. Results that comply with requirements.
 - 3. Results that do not comply with requirements, and corrective action taken to achieve compliance with requirements.
- 3.9 **PAYMENT**
- A. Lump sum price for Electrical Construction – Lighting Complete covers all items of work in this Special Provision including furnishing labor, materials, tools, equipment, and incidentals required to complete the work.

END OF SECTION

State Road and Tollway Authority (SRTA), State of Georgia

SPECIAL PROVISION

Section 999 – Electrical Construction – Lighting Complete

Section 262416 – Panelboards

PART 1 - GENERAL

1.1 RELATED DOCUMENTS

- A. Drawings and general provisions of the Contract, including General and Supplementary Conditions and Division 01 Specification Sections, apply to this Section.

1.2 SUMMARY

- A. Section Includes:
 1. Distribution panelboards.
 2. Lighting and appliance branch-circuit panelboards.

1.3 DEFINITIONS

- A. ATS: Acceptance testing specification.
- B. GFCI: Ground-fault circuit interrupter.
- C. GFEP: Ground-fault equipment protection.
- D. MCCB: Molded-case circuit breaker.
- E. SPD: Surge protective device.
- F. VPR: Voltage protection rating.

1.4 ACTION SUBMITTALS

- A. Product Data: For each type of panelboard.
 1. Include materials, switching and overcurrent protective devices, SPDs, accessories, and components indicated.
 2. Include dimensions and manufacturers' technical data on features, performance, electrical characteristics, ratings, and finishes.

- B. **Shop Drawings:** For each panelboard and related equipment.
1. Include dimensioned plans, elevations, sections, and details.
 2. Show tabulations of installed devices with nameplates, conductor termination sizes, equipment features, and ratings.
 3. Detail enclosure types including mounting and anchorage, environmental protection, knockouts, corner treatments, covers and doors, gaskets, hinges, and locks.
 4. Detail bus configuration, current, and voltage ratings.
 5. Short-circuit current rating of panelboards and overcurrent protective devices.
 6. Include evidence of NRTL listing for series rating of installed devices.
 7. Include evidence of NRTL listing for SPD as installed in panelboard.
 8. Detail features, characteristics, ratings, and factory settings of individual overcurrent protective devices and auxiliary components.
 9. Include wiring diagrams for power, signal, and control wiring.
 10. Key interlock scheme drawing and sequence of operations.
 11. Include time-current coordination curves for each type and rating of overcurrent protective device included in panelboards. Submit on translucent log-log graph paper; include selectable ranges for each type of overcurrent protective device. Include an Internet link for electronic access to downloadable PDF of the coordination curves.

1.5 INFORMATIONAL SUBMITTALS

- A. **Qualification Data:** For testing agency.
- B. **Panelboard Schedules:** For installation in panelboards. Submit final versions after load balancing.

1.6 CLOSEOUT SUBMITTALS

- A. **Operation and Maintenance Data:** For panelboards and components to include in emergency, operation, and maintenance manuals. In addition to items specified in Section 017823 "Operation and Maintenance Data," include the following:
1. Manufacturer's written instructions for testing and adjusting overcurrent protective devices.
 2. Time-current curves, including selectable ranges for each type of overcurrent protective device that allows adjustments.

1.7 MAINTENANCE MATERIAL SUBMITTALS

- A. **Furnish extra materials that match products installed and that are packaged with protective covering for storage and identified with labels describing contents.**
1. **Keys:** Two spares for each type of panelboard cabinet lock.
 2. **Circuit Breakers Including GFCI and GFEP Types:** Two spares for each panelboard.
 3. **Fuses for Fused Switches:** Equal to 10 percent of quantity installed for each size and type, but no fewer than three of each size and type.
 4. **Fuses for Fused Power-Circuit Devices:** Equal to 10 percent of quantity installed for each size and type, but no fewer than three of each size and type.

1.8 QUALITY ASSURANCE

- A. Manufacturer Qualifications: ISO 9001 or 9002 certified.

1.9 DELIVERY, STORAGE, AND HANDLING

- A. Remove loose packing and flammable materials from inside panelboards; install temporary electric heating (250 W per panelboard) to prevent condensation.
- B. Handle and prepare panelboards for installation according to NECA 407 NEMA PB 1.

1.10 FIELD CONDITIONS

- A. Environmental Limitations:
 1. Do not deliver or install panelboards until spaces are enclosed and weathertight, wet work in spaces is complete and dry, work above panelboards is complete, and temporary HVAC system is operating and maintaining ambient temperature and humidity conditions at occupancy levels during the remainder of the construction period.
 2. Rate equipment for continuous operation under the following conditions unless otherwise indicated:
 - a. Ambient Temperature: Not exceeding minus 22 deg F.
 - b. Altitude: Not exceeding 6600 feet.
- B. Service Conditions: NEMA PB 1, usual service conditions, as follows:
 1. Ambient temperatures within limits specified.
 2. Altitude not exceeding 6600 feet.
- C. Interruption of Existing Electric Service: Do not interrupt electric service to facilities occupied by Owner or others unless permitted under the following conditions and then only after arranging to provide temporary electric service according to requirements indicated:
 1. Notify Construction Manager no fewer than two days in advance of proposed interruption of electric service.
 2. Do not proceed with interruption of electric service without Construction Manager's written permission.
 3. Comply with NFPA 70E.

1.11 WARRANTY

- A. Manufacturer's Warranty: Manufacturer agrees to repair or replace panelboards that fail in materials or workmanship within specified warranty period.
 1. Panelboard Warranty Period: 18 months from date of Substantial Completion.
- B. Special Warranty: Manufacturer's standard form in which manufacturer agrees to repair or replace SPD that fails in materials or workmanship within specified warranty period.
 1. SPD Warranty Period: Five years from date of Substantial Completion.

PART 2 - PRODUCTS

2.1 PANELBOARDS COMMON REQUIREMENTS

- A. **Product Selection for Restricted Space:** Drawings indicate maximum dimensions for panelboards including clearances between panelboards and adjacent surfaces and other items. Comply with indicated maximum dimensions.
- B. **Electrical Components, Devices, and Accessories:** Listed and labeled as defined in NFPA 70, by a qualified testing agency, and marked for intended location and application.
- C. Comply with NEMA PB 1.
- D. Comply with NFPA 70.
- E. **Enclosures: Flush and Surface-mounted, dead-front cabinets.**
 - 1. **Rated for environmental conditions at installed location.**
 - a. **Indoor Dry and Clean Locations:** NEMA 250, Type 1.
 - b. **Outdoor Locations:** NEMA 250, Type 3R.
 - 2. **Height:** 84 inches maximum.
 - 3. **Front:** Secured to box with concealed trim clamps. For surface-mounted fronts, match box dimensions; for flush-mounted fronts, overlap box. Trims shall cover all live parts and shall have no exposed hardware.
 - 4. **Hinged Front Cover:** Entire front trim hinged to box and with standard door within hinged trim cover. Trims shall cover all live parts and shall have no exposed hardware.
 - 5. **Skirt for Surface-Mounted Panelboards:** Same gage and finish as panelboard front with flanges for attachment to panelboard, wall, and ceiling or floor.
 - 6. **Gutter Extension and Barrier:** Same gage and finish as panelboard enclosure; integral with enclosure body. Arrange to isolate individual panel sections.
 - 7. **Finishes:**
 - a. **Panels and Trim:** Steel and galvanized steel, factory finished immediately after cleaning and pretreating with manufacturer's standard two-coat, baked-on finish consisting of prime coat and thermosetting topcoat.
 - b. **Back Boxes:** Galvanized steel Same finish as panels and trim.
 - c. **Fungus Proofing:** Permanent fungicidal treatment for overcurrent protective devices and other components.
- F. **Incoming Mains:**
 - 1. **Location:** Top.
 - 2. **Main Breaker:** Main lug interiors up to 400 amperes shall be field convertible to main breaker.
- G. **Phase, Neutral, and Ground Buses:**
 - 1. **Material:** Tin-plated copper.
 - a. **Plating shall run entire length of bus.**
 - b. **Bus shall be fully rated the entire length.**

2. Interiors shall be factory assembled into a unit. Replacing switching and protective devices shall not disturb adjacent units or require removing the main bus connectors.
 3. **Equipment Ground Bus:** Adequate for feeder and branch-circuit equipment grounding conductors; bonded to box.
 4. **Isolated Ground Bus:** Adequate for branch-circuit isolated ground conductors; insulated from box.
 5. **Full-Sized Neutral:** Equipped with full-capacity bonding strap for service entrance applications. Mount electrically isolated from enclosure. Do not mount neutral bus in gutter.
 6. **Extra-Capacity Neutral Bus:** Neutral bus rated 200 percent of phase bus and listed and labeled by an NRTL acceptable to authority having jurisdiction, as suitable for nonlinear loads in electronic-grade panelboards and others designated on Drawings. Connectors shall be sized for double-sized or parallel conductors as indicated on Drawings. Do not mount neutral bus in gutter.
 7. **Split Bus:** Not allowed.
- H. **Conductor Connectors:** Suitable for use with conductor material and sizes.
1. **Material:** Hard-drawn copper, 98 percent conductivity.
 2. **Terminations** shall allow use of 75 deg C rated conductors without derating.
 3. **Size:** Lugs suitable for indicated conductor sizes, with additional gutter space, if required, for larger conductors.
 4. **Main and Neutral Lugs:** Compression type, with a lug on the neutral bar for each pole in the panelboard.
 5. **Ground Lugs and Bus-Configured Terminators:** Compression type, with a lug on the bar for each pole in the panelboard.
 6. **Feed-Through Lugs:** Compression type, suitable for use with conductor material. Locate at opposite end of bus from incoming lugs or main device.
 7. **Subfeed (Double) Lugs:** Compression type suitable for use with conductor material. Locate at same end of bus as incoming lugs or main device.
 8. **Gutter-Tap Lugs:** Compression type suitable for use with conductor material and with matching insulating covers. Locate at same end of bus as incoming lugs or main device.
- I. **NRTL Label:** Panelboards or load centers shall be labeled by an NRTL acceptable to authority having jurisdiction for use as service equipment with one or more main service disconnecting and overcurrent protective devices. Panelboards or load centers shall have meter enclosures, wiring, connections, and other provisions for utility metering. Coordinate with utility company for exact requirements.
- J. **Future Devices:** Panelboards or load centers shall have mounting brackets, bus connections, filler plates, and necessary appurtenances required for future installation of devices.
1. **Percentage of Future Space Capacity:** Five percent.
- K. **Panelboard Short-Circuit Current Rating:** Rated for series-connected system with integral or remote upstream overcurrent protective devices and labeled by an NRTL. Include label or manual with size and type of allowable upstream and branch devices listed and labeled by an NRTL for series-connected short-circuit rating.
1. **Panelboards** rated 240 V or less shall have short-circuit ratings as shown on Drawings, but not less than 10,000 A rms symmetrical.
 2. **Panelboards** rated above 240 V and less than 600 V shall have short-circuit ratings as shown on Drawings, but not less than 14,000 A rms symmetrical.

- L. **Panelboard Short-Circuit Current Rating:** Fully rated to interrupt symmetrical short-circuit current available at terminals. Assembly listed by an NRTL for 100 percent interrupting capacity.
 - 1. Panelboards and overcurrent protective devices rated 240 V or less shall have short-circuit ratings as shown on Drawings, but not less than 10,000 A rms symmetrical.
 - 2. Panelboards and overcurrent protective devices rated above 240 V and less than 600 V shall have short-circuit ratings as shown on Drawings, but not less than 14,000 A rms symmetrical.

2.2 PERFORMANCE REQUIREMENTS

- A. **Surge Suppression:** Factory installed as an integral part of indicated panelboards, complying with UL 1449 SPD Type 1.

2.3 POWER PANELBOARDS

- A. 1. Schneider Square D. 2. General Electric GE 3. Siemens.
- B. **Panelboards:** NEMA PB 1, distribution type.
- C. **Doors:** Secured with vault-type latch with tumbler lock; keyed alike.
 - 1. For doors more than 36 inches high, provide two latches, keyed alike.
- D. **Mains:** Circuit breaker.
- E. **Branch Overcurrent Protective Devices for Circuit-Breaker Frame Sizes 125 A and Smaller:** Bolt-on circuit breakers.
- F. **Branch Overcurrent Protective Devices for Circuit-Breaker Frame Sizes Larger Than 125 A:** Bolt-on circuit breakers.
- G. **Branch Overcurrent Protective Devices:** Fused switches.
- H. **Contactors in Main Bus:** NEMA ICS 2, Class A, electrically held, general-purpose controller, with same short-circuit interrupting rating as panelboard.
 - 1. **Internal Control-Power Source:** Control-power transformer, with fused primary and secondary terminals, connected to main bus ahead of contactor connection.
 - 2. **External Control-Power Source:** 120-V branch circuit.
- I. **Buses:**
 - 1. Copper phase and neutral buses; 100 percent capacity neutral bus and lugs.
 - 2. Copper equipment and isolated ground buses.
 - a. Standard ampere ratings and number of poles.
 - b. Mechanical cover interlock with a manual interlock override, to prevent the opening of the cover when the switch is in the on position. The interlock shall prevent the switch from being turned on with the cover open. The operating handle shall have lock-off means with provisions for three padlocks.

- c. **Auxiliary Contacts:** One normally open and normally closed contact(s) that operate with switch handle operation.

2.4 IDENTIFICATION

- A. **Panelboard Label:** Manufacturer's name and trademark, voltage, amperage, number of phases, and number of poles shall be located on the interior of the panelboard door.
- B. **Breaker Labels:** Faceplate shall list current rating, UL and IEC certification standards, and AIC rating.
- C. **Circuit Directory:** Directory card inside panelboard door, mounted in transparent card holder.
 - 1. Circuit directory shall identify specific purpose with detail sufficient to distinguish it from all other circuits.
- D. **Circuit Directory:** Computer-generated circuit directory mounted inside panelboard door with transparent plastic protective cover.
 - 1. Circuit directory shall identify specific purpose with detail sufficient to distinguish it from all other circuits.

2.5 ACCESSORY COMPONENTS AND FEATURES

- A. **Accessory Set:** Include tools and miscellaneous items required for overcurrent protective device test, inspection, maintenance, and operation.
- B. **Portable Test Set:** For testing functions of solid-state trip devices without removing from panelboard. Include relay and meter test plugs suitable for testing panelboard meters and switchboard class relays.

PART 3 - EXECUTION

3.1 EXAMINATION

- A. Verify actual conditions with field measurements prior to ordering panelboards to verify that equipment fits in allocated space in, and comply with, minimum required clearances specified in NFPA 70.
- B. Receive, inspect, handle, and store panelboards according to NECA 407 NEMA PB 1.1.
- C. Examine panelboards before installation. Reject panelboards that are damaged, rusted, or have been subjected to water saturation.
- D. Examine elements and surfaces to receive panelboards for compliance with installation tolerances and other conditions affecting performance of the Work.
- E. Proceed with installation only after unsatisfactory conditions have been corrected.

3.2 INSTALLATION

- A. Coordinate layout and installation of panelboards and components with other construction that penetrates walls or is supported by them, including electrical and other types of equipment, raceways, piping, encumbrances to workspace clearance requirements, and adjacent surfaces. Maintain required workspace clearances and required clearances for equipment access doors and panels.
- B. Comply with NECA 1.
- C. Install panelboards and accessories according to NECA 407 NEMA PB 1.1.
- D. Equipment Mounting:
 - 1. Install panelboards on cast-in-place concrete equipment base(s). Comply with requirements for equipment bases and foundations specified in Section 033000 "Cast-in-Place Concrete." Section 033053 "Miscellaneous Cast-in-Place Concrete."
 - 2. Attach panelboard to the vertical finished or structural surface behind the panelboard.
 - 3. Comply with requirements for seismic control devices specified in Section 260548.16 "Seismic Controls for Electrical Systems."
- E. Temporary Lifting Provisions: Remove temporary lifting eyes, channels, and brackets and temporary blocking of moving parts from panelboards.
- F. Comply with mounting and anchoring requirements specified in Section 260548.16 "Seismic Controls for Electrical Systems."
- G. Mount top of trim 90 inches above finished floor unless otherwise indicated.
- H. Mount panelboard cabinet plumb and rigid without distortion of box.
- I. Mount recessed panelboards with fronts uniformly flush with wall finish and mating with back box.
- J. Mount surface-mounted panelboards to steel slotted supports 5/8 inch in depth. Orient steel slotted supports vertically.
- K. Install overcurrent protective devices and controllers not already factory installed.
 - 1. Set field-adjustable, circuit-breaker trip ranges.
 - 2. Tighten bolted connections and circuit breaker connections using calibrated torque wrench or torque screwdriver per manufacturer's written instructions.
- L. Make grounding connections and bond neutral for services and separately derived systems to ground. Make connections to grounding electrodes, separate grounds for isolated ground bars, and connections to separate ground bars.
- M. Install filler plates in unused spaces.
- N. Arrange conductors in gutters into groups and bundle and wrap with wire ties after completing load balancing.
- O. Mount spare fuse cabinet in accessible location.

3.3 IDENTIFICATION

- A. Identify field-installed conductors, interconnecting wiring, and components; install warning signs complying with requirements in Section 260553 "Identification for Electrical Systems."
- B. Create a directory to indicate installed circuit loads after balancing panelboard loads; incorporate Owner's final room designations. Obtain approval before installing. Handwritten directories are not acceptable. Install directory inside panelboard door.
- C. Panelboard Nameplates: Label each panelboard with a nameplate complying with requirements for identification specified in Section 260553 "Identification for Electrical Systems."
- D. Device Nameplates: Label each branch circuit device in power panelboards with a nameplate complying with requirements for identification specified in Section 260553 "Identification for Electrical Systems."
- E. Install warning signs complying with requirements in Section 260553 "Identification for Electrical Systems" identifying source of remote circuit.

3.4 FIELD QUALITY CONTROL

- A. Manufacturer's Field Service: Engage a factory-authorized service representative to inspect, test, and adjust components, assemblies, and equipment installations, including connections.
- B. Perform tests and inspections.
 - 1. Manufacturer's Field Service: Engage a factory-authorized service representative to inspect components, assemblies, and equipment installations, including connections, and to assist in testing.
- C. Acceptance Testing Preparation:
 - 1. Test insulation resistance for each panelboard bus, component, connecting supply, feeder, and control circuit.
 - 2. Test continuity of each circuit.
- D. Tests and Inspections:
 - 1. Perform each visual and mechanical inspection and electrical test for low-voltage air circuit breakers and low-voltage surge arrestors stated in NETA ATS, Paragraph 7.6 Circuit Breakers and Paragraph 7.19.1 Surge Arrestors, Low-Voltage. Perform optional tests. Certify compliance with test parameters.
 - 2. Correct malfunctioning units on-site, where possible, and retest to demonstrate compliance; otherwise, replace with new units and retest.
 - 3. Perform the following infrared scan tests and inspections and prepare reports:
 - a. Initial Infrared Scanning: After Substantial Completion, but not more than 60 days after Final Acceptance, perform an infrared scan of each panelboard. Remove front panels so joints and connections are accessible to portable scanner.
 - b. Follow-up Infrared Scanning: Perform an additional follow-up infrared scan of each panelboard 11 months after date of Substantial Completion.
 - c. Instruments and Equipment:

- 1) Use an infrared scanning device designed to measure temperature or to detect significant deviations from normal values. Provide calibration record for device.

- E. Panelboards will be considered defective if they do not pass tests and inspections.
- F. Prepare test and inspection reports, including a certified report that identifies panelboards included and that describes scanning results, with comparisons of the two scans. Include notation of deficiencies detected, remedial action taken, and observations after remedial action.

3.5 ADJUSTING

- A. Adjust moving parts and operable components to function smoothly, and lubricate as recommended by manufacturer.
- B. Set field-adjustable circuit-breaker trip ranges as indicated.
- C. Load Balancing: After Substantial Completion, but not more than 60 days after Final Acceptance, measure load balancing and make circuit changes. Prior to making circuit changes to achieve load balancing, inform Architect of effect on phase color coding.
 1. Measure loads during period of normal facility operations.
 2. Perform circuit changes to achieve load balancing outside normal facility operation schedule or at times directed by the Architect. Avoid disrupting services such as fax machines and on-line data processing, computing, transmitting, and receiving equipment.
 3. After changing circuits to achieve load balancing, recheck loads during normal facility operations. Record load readings before and after changing circuits to achieve load balancing.
 4. Tolerance: Maximum difference between phase loads, within a panelboard, shall not exceed 20 percent.

3.6 PROTECTION

- A. Temporary Heating: Prior to energizing panelboards, apply temporary heat to maintain temperature according to manufacturer's written instructions.

3.7 PAYMENT

- A. Lump sum price for Electrical Construction – Lighting Complete covers all items of work in this Special Provision including furnishing labor, materials, tools, equipment, and incidentals required to complete the work.

END OF SECTION

State Road and Tollway Authority (SRTA), State of Georgia

SPECIAL PROVISION

Section 999 – Electrical Construction – Lighting Complete

Section 260533 – Raceways and Boxes for Electrical Systems

PART 1 - GENERAL

1.1 RELATED DOCUMENTS

- A. Drawings and general provisions of the Contract, including General and Supplementary Conditions and Division 01 Specification Sections, apply to this Section.

1.2 SUMMARY

- A. Section Includes:
 1. Metal conduits and fittings.
 2. Nonmetallic conduits and fittings.
 3. Surface raceways.
 4. Boxes, enclosures, and cabinets.
 5. Handholes and boxes for exterior underground cabling.

1.3 DEFINITIONS

- A. GRC: Galvanized rigid steel conduit.
- B. IMC: Intermediate metal conduit.

1.4 ACTION SUBMITTALS

- A. **Product Data:** For surface raceways, wireways and fittings, floor boxes, hinged-cover enclosures, and cabinets.
- B. **Shop Drawings:** For custom enclosures and cabinets. Include plans, elevations, sections, and attachment details.

1.5 INFORMATIONAL SUBMITTALS

- A. **Coordination Drawings:** Conduit routing plans, drawn to scale, on which the following items are shown and coordinated with each other, using input from installers of items involved:

1. Structural members in paths of conduit groups with common supports.
 2. HVAC and plumbing items and architectural features in paths of conduit groups with common supports.
- B. Qualification Data: For professional engineer.
1. Basis for Certification: Indicate whether withstand certification is based on actual test of assembled components or on calculation.
 2. Dimensioned Outline Drawings of Equipment Unit: Identify center of gravity and locate and describe mounting and anchorage provisions.
 3. Detailed description of equipment anchorage devices on which the certification is based and their installation requirements.
 4. Detailed description of conduit support devices and interconnections on which the certification is based and their installation requirements.
- C. Source quality-control reports.

PART 2 - PRODUCTS

2.1 METAL CONDUITS AND FITTINGS

- A. Metal Conduit:
1. Listing and Labeling: Listed and labeled as defined in NFPA 70, by a qualified testing agency, and marked for intended location and application.
 2. GRC: Comply with ANSI C80.1 and UL 6.
 3. IMC: Comply with ANSI C80.6 and UL 1242.
 4. EMT: Comply with ANSI C80.3 and UL 797.
 5. FMC: Comply with UL 1; zinc-coated steel.
 6. LFMC: Flexible steel conduit with PVC jacket and complying with UL 360.
- B. Metal Fittings:
1. Comply with NEMA FB 1 and UL 514B.
 2. Listing and Labeling: Listed and labeled as defined in NFPA 70, by a qualified testing agency, and marked for intended location and application.
 3. Fittings, General: Listed and labeled for type of conduit, location, and use.
 4. Conduit Fittings for Hazardous (Classified) Locations: Comply with UL 1203 and NFPA 70.
 5. Fittings for EMT:
 - a. Material: Steel
 - b. Type: compression.
 6. Expansion Fittings: PVC or steel to match conduit type, complying with UL 651, rated for environmental conditions where installed, and including flexible external bonding jumper.
 7. Coating for Fittings for PVC-Coated Conduit: Minimum thickness of 0.040 inch, with overlapping sleeves protecting threaded joints.

- C. **Joint Compound for IMC, GRC:** Approved, as defined in NFPA 70, by authorities having jurisdiction for use in conduit assemblies, and compounded for use to lubricate and protect threaded conduit joints from corrosion and to enhance their conductivity.

2.2 NONMETALLIC CONDUITS AND FITTINGS

- A. **Nonmetallic Conduit:**
 1. **Listing and Labeling:** Nonmetallic conduit shall be listed and labeled as defined in NFPA 70, by a qualified testing agency, and marked for intended location and application.
 2. **RNC: Type EPC-40-PVC,** complying with NEMA TC 2 and UL 651 unless otherwise indicated.
- B. **Nonmetallic Fittings:**
 1. **Fittings, General:** Listed and labeled for type of conduit, location, and use.
 2. **Fittings for RNC:** Comply with NEMA TC 3; match to conduit or tubing type and material.
 3. **Solvents and Adhesives:** As recommended by conduit manufacturer.

2.3 SURFACE RACEWAYS

- A. **Listing and Labeling:** Surface raceways and tele-power poles shall be listed and labeled as defined in NFPA 70, by a qualified testing agency, and marked for intended location and application.
- B. **Surface Metal Raceways:** Galvanized steel with snap-on covers complying with UL 5. Manufacturer's standard enamel finish in color selected by Architect.
- C. **Surface Nonmetallic Raceways:** Two- or three-piece construction, complying with UL 5A, and manufactured of rigid PVC with texture and color selected by Architect from manufacturer's standard colors. Product shall comply with UL 94 V-0 requirements for self-extinguishing characteristics.

2.4 BOXES, ENCLOSURES, AND CABINETS

- A. **General Requirements for Boxes, Enclosures, and Cabinets:** Boxes, enclosures, and cabinets installed in wet locations shall be listed for use in wet locations.
- B. **Sheet Metal Outlet and Device Boxes:** Comply with NEMA OS 1 and UL 514A.
- C. **Cast-Metal Outlet and Device Boxes:** Comply with NEMA FB 1, aluminum, Type FD, with gasketed cover.
- D. **Nonmetallic Outlet and Device Boxes:** Comply with NEMA OS 2 and UL 514C.
- E. **Luminaire Outlet Boxes:** Nonadjustable, designed for attachment of luminaire weighing 50 lb. Outlet boxes designed for attachment of luminaires weighing more than 50 lb shall be listed and marked for the maximum allowable weight.
- F. **Small Sheet Metal Pull and Junction Boxes:** NEMA OS 1.

- G. **Cast-Metal Access, Pull, and Junction Boxes:** Comply with NEMA FB 1 and UL 1773, cast aluminum with gasketed cover.
- H. **Box extensions used to accommodate new building finishes** shall be of same material as recessed box.
- I. **Device Box Dimensions:** 4 inches square by 2-1/8 inches deep.
- J. **Gangable boxes** are prohibited.

2.5 HANDHOLES AND BOXES FOR EXTERIOR UNDERGROUND WIRING

- A. **General Requirements for Handholes and Boxes:**
 - 1. **Boxes and handholes for use in underground systems** shall be designed and identified as defined in NFPA 70, for intended location and application.
 - 2. **Boxes installed in wet areas** shall be listed and labeled as defined in NFPA 70, by a qualified testing agency, and marked for intended location and application.
- B. **Polymer-Concrete Handholes and Boxes with Polymer-Concrete Cover:** Molded of sand and aggregate, bound together with polymer resin, and reinforced with steel, fiberglass, or a combination of the two.
 - 1. **Standard:** Comply with SCTE 77.
 - 2. **Configuration:** Designed for flush burial with open bottom unless otherwise indicated.
 - 3. **Cover:** Weatherproof, secured by tamper-resistant locking devices and having structural load rating consistent with enclosure and handhole location.
 - 4. **Cover Finish:** Nonskid finish shall have a minimum coefficient of friction of 0.50.
 - 5. **Cover Legend:** Molded lettering, "ELECTRIC," "LIGHTING" and "FIBER OPTIC"
 - 6. **Conduit Entrance Provisions:** Conduit-terminating fittings shall mate with entering ducts for secure, fixed installation in enclosure wall.
 - 7. **Handholes 17 Inches Wide by 30 Inches Long and Larger:** Have inserts for cable racks and pulling-in irons installed before concrete is poured.

2.6 SOURCE QUALITY CONTROL FOR UNDERGROUND ENCLOSURES

- A. **Handhole and Pull-Box Prototype Test:** Test prototypes of handholes and boxes for compliance with SCTE 77. Strength tests shall be for specified tier ratings of products supplied.
 - 1. **Tests of materials** shall be performed by an independent testing agency.
 - 2. **Strength tests of complete boxes and covers** shall be by either an independent testing agency or manufacturer. A qualified registered professional engineer shall certify tests by manufacturer.
 - 3. **Testing machine pressure gages** shall have current calibration certification complying with ISO 9000 and ISO 10012 and traceable to NIST standards.

PART 3 - EXECUTION

3.1 RACEWAY APPLICATION

- A. Outdoors: Apply raceway products as specified below unless otherwise indicated:
1. Exposed Conduit: GRC, IMC, RNC.
 2. Concealed Conduit, Aboveground: GRC, IMC, EMT, RNC, Type EPC-40-PVC.
 3. Underground Conduit: RNC, Type EPC-40-PVC Type EPC-80-PVC.
 4. Boxes and Enclosures, Aboveground: NEMA Type 3R.
- B. Indoors: Apply raceway products as specified below unless otherwise indicated:
1. Exposed, Not Subject to Physical Damage: EMT.
 2. Exposed, Not Subject to Severe Physical Damage: EMT.
 3. Exposed and Subject to Severe Physical Damage: GRC, IMC. Raceway locations include the following:
 - a. Mechanical rooms.
 4. Concealed in Ceilings and Interior Walls and Partitions: EMT.
 5. Connection to Vibrating Equipment (Including Transformers and Hydraulic, Pneumatic, Electric Solenoid, or Motor-Driven Equipment): FMC, except use LFMC in damp or wet locations.
 6. Damp or Wet Locations: GRC, IMC.
- C. Minimum Raceway Size: 3/4-inch trade size.
- D. Raceway Fittings: Compatible with raceways and suitable for use and location.
1. Rigid and Intermediate Steel Conduit: Use threaded rigid steel conduit fittings unless otherwise indicated. Comply with NEMA FB 2.10.
 2. PVC Externally Coated, Rigid Steel Conduits: Use only fittings listed for use with this type of conduit. Patch and seal all joints, nicks, and scrapes in PVC coating after installing conduits and fittings. Use sealant recommended by fitting manufacturer and apply in thickness and number of coats recommended by manufacturer.
 3. EMT: Use compression, steel fittings. Comply with NEMA FB 2.10.
 4. Flexible Conduit: Use only fittings listed for use with flexible conduit. Comply with NEMA FB 2.20.
- E. Install surface raceways only where indicated on Drawings.
- F. Do not install nonmetallic conduit where ambient temperature exceeds 120 deg F.

3.2 INSTALLATION

- A. Comply with NECA 1 and NECA 101 for installation requirements except where requirements on Drawings or in this article are stricter. Comply with NECA 102 for aluminum conduits. Comply with NFPA 70 limitations for types of raceways allowed in specific occupancies and number of floors.

- B. Keep raceways at least 6 inches away from parallel runs of flues and steam or hot-water pipes. Install horizontal raceway runs above water and steam piping.
- C. Complete raceway installation before starting conductor installation.
- D. Comply with requirements in Section 260529 "Hangers and Supports for Electrical Systems" for hangers and supports.
- E. Arrange stub-ups so curved portions of bends are not visible above finished slab.
- F. Install no more than the equivalent of three 90-degree bends in any conduit run except for control wiring conduits, for which fewer bends are allowed. Support within 12 inches of changes in direction.
- G. Conceal conduit and EMT within finished walls, ceilings, and floors unless otherwise indicated. Install conduits parallel or perpendicular to building lines.
- H. Support conduit within 12 inches of enclosures to which attached.
- I. Raceways Embedded in Slabs:
 1. Run conduit larger than 1-inch trade size, parallel or at right angles to main reinforcement. Where at right angles to reinforcement, place conduit close to slab support. Secure raceways to reinforcement at maximum 10-foot intervals.
 2. Arrange raceways to cross building expansion joints at right angles with expansion fittings.
 3. Arrange raceways to keep a minimum of 1 inch of concrete cover in all directions.
 4. Do not embed threadless fittings in concrete unless specifically approved by Architect for each specific location.
 5. Change from ENT to RNC, Type EPC-40-PVC, GRC or IMC before rising above floor.
- J. Stub-ups to Above Recessed Ceilings:
 1. Use EMT, IMC, or RMC for raceways.
 2. Use a conduit bushing or insulated fitting to terminate stub-ups not terminated in hubs or in an enclosure.
- K. Threaded Conduit Joints, Exposed to Wet, Damp, Corrosive, or Outdoor Conditions: Apply listed compound to threads of raceway and fittings before making up joints. Follow compound manufacturer's written instructions.
- L. Coat field-cut threads on PVC-coated raceway with a corrosion-preventing conductive compound prior to assembly.
- M. Raceway Terminations at Locations Subject to Moisture or Vibration: Use insulating bushings to protect conductors including conductors smaller than No. 4 AWG.
- N. Terminate threaded conduits into threaded hubs or with locknuts on inside and outside of boxes or cabinets. Install bushings on conduits up to 1-1/4-inch trade size and insulated throat metal bushings on 1-1/2-inch trade size and larger conduits terminated with locknuts. Install insulated throat metal grounding bushings on service conduits.
- O. Install raceways square to the enclosure and terminate at enclosures with locknuts. Install locknuts hand tight plus 1/4 turn more.

- P. Do not rely on locknuts to penetrate nonconductive coatings on enclosures. Remove coatings in the locknut area prior to assembling conduit to enclosure to assure a continuous ground path.
- Q. Cut conduit perpendicular to the length. For conduits 2-inch trade size and larger, use roll cutter or a guide to make cut straight and perpendicular to the length.
- R. Install pull wires in empty raceways. Use polypropylene or monofilament plastic line with not less than 200-lb tensile strength. Leave at least 12 inches of slack at each end of pull wire. Cap underground raceways designated as spare above grade alongside raceways in use.
- S. **Surface Raceways:**
 - 1. Install surface raceway with a minimum 2-inch radius control at bend points.
 - 2. Secure surface raceway with screws or other anchor-type devices at intervals not exceeding 48 inches and with no less than two supports per straight raceway section. Support surface raceway according to manufacturer's written instructions. Tape and glue are not acceptable support methods.
- T. Install raceway sealing fittings at accessible locations according to NFPA 70 and fill them with listed sealing compound. For concealed raceways, install each fitting in a flush steel box with a blank cover plate having a finish similar to that of adjacent plates or surfaces. Install raceway sealing fittings according to NFPA 70.
- U. Install devices to seal raceway interiors at accessible locations. Locate seals so no fittings or boxes are between the seal and the following changes of environments. Seal the interior of all raceways at the following points:
 - 1. Where conduits pass from warm to cold locations, such as boundaries of refrigerated spaces.
 - 2. Where an underground service raceway enters a building or structure.
 - 3. Where otherwise required by NFPA 70.
- V. Comply with manufacturer's written instructions for solvent welding RNC and fittings.
- W. **Flexible Conduit Connections:** Comply with NEMA RV 3. Use a maximum of 72 inches of flexible conduit for recessed and semi recessed luminaires, equipment subject to vibration, noise transmission, or movement; and for transformers and motors.
 - 1. Use LFMC in damp or wet locations subject to severe physical damage.
 - 2. Use LFMC in damp or wet locations not subject to severe physical damage.
- X. Mount boxes at heights indicated on Drawings. If mounting heights of boxes are not individually indicated, give priority to ADA requirements. Install boxes with height measured to center of box unless otherwise indicated.
- Y. **Recessed Boxes in Masonry Walls:** Saw-cut opening for box in center of cell of masonry block, and install box flush with surface of wall. Prepare block surfaces to provide a flat surface for a raintight connection between box and cover plate or supported equipment and box.
- Z. Horizontally separate boxes mounted on opposite sides of walls so they are not in the same vertical channel.
- AA. Locate boxes so that cover or plate will not span different building finishes.

- BB. Support boxes of three gangs or more from more than one side by spanning two framing members or mounting on brackets specifically designed for the purpose.
- CC. Fasten junction and pull boxes to or support from building structure. Do not support boxes by conduits.
- DD. Set metal floor boxes level and flush with finished floor surface.
- EE. Set nonmetallic floor boxes level. Trim after installation to fit flush with finished floor surface.

3.3 INSTALLATION OF UNDERGROUND CONDUIT

A. Direct-Buried Conduit:

1. Excavate trench bottom to provide firm and uniform support for conduit. Prepare trench bottom as specified in Section 312000 "Earth Moving" for pipe less than 6 inches in nominal diameter.
2. Install backfill as specified in Section 312000 "Earth Moving."
3. After installing conduit, backfill and compact. Start at tie-in point, and work toward end of conduit run, leaving conduit at end of run free to move with expansion and contraction as temperature changes during this process. Firmly hand tamp backfill around conduit to provide maximum supporting strength. After placing controlled backfill to within 12 inches of finished grade, make final conduit connection at end of run and complete backfilling with normal compaction as specified in Section 312000 "Earth Moving."
4. Install manufactured duct elbows for stub-ups at poles and equipment and at building entrances through floor unless otherwise indicated. Encase elbows for stub-up ducts throughout length of elbow.
5. Install manufactured rigid steel conduit elbows for stub-ups at poles and equipment and at building entrances through floor.
 - a. Couple steel conduits to ducts with adapters designed for this purpose, and encase coupling with 3 inches of concrete for a minimum of 12 inches on each side of the coupling.
 - b. For stub-ups at equipment mounted on outdoor concrete bases and where conduits penetrate building foundations, extend steel conduit horizontally a minimum of 60 inches from edge of foundation or equipment base. Install insulated grounding bushings on terminations at equipment.
6. Warning Planks: Bury warning planks approximately 12 inches above direct-buried conduits but a minimum of 6 inches below grade. Align planks along centerline of conduit.
7. Underground Warning Tape: Comply with requirements in Section 260553 "Identification for Electrical Systems."

3.4 INSTALLATION OF UNDERGROUND HANDHOLES AND BOXES

- A. Install handholes and boxes level and plumb and with orientation and depth coordinated with connecting conduits to minimize bends and deflections required for proper entrances.
- B. Unless otherwise indicated, support units on a level bed of crushed stone or gravel, graded from 1/2-inch sieve to No. 4 sieve and compacted to same density as adjacent undisturbed earth.

- C. Elevation: In paved areas, set so cover surface will be flush with finished grade. Set covers of other enclosures 1 inch above finished grade.
- D. Install handholes with bottom below frost line, below grade.
- E. Install removable hardware, including pulling eyes, cable stanchions, cable arms, and insulators, as required for installation and support of cables and conductors and as indicated. Select arm lengths to be long enough to provide spare space for future cables but short enough to preserve adequate working clearances in enclosure.
- F. Field-cut openings for conduits according to enclosure manufacturer's written instructions. Cut wall of enclosure with a tool designed for material to be cut. Size holes for terminating fittings to be used, and seal around penetrations after fittings are installed.

3.5 SLEEVE AND SLEEVE-SEAL INSTALLATION FOR ELECTRICAL PENETRATIONS

- A. Install sleeves and sleeve seals at penetrations of exterior floor and wall assemblies.

3.6 FIRESTOPPING

- A. Install firestopping at penetrations of fire-rated floor and wall assemblies. Comply with requirements in Section 078413 "Penetration Firestopping."

3.7 PROTECTION

- A. Protect coatings, finishes, and cabinets from damage and deterioration.
 1. Repair damage to galvanized finishes with zinc-rich paint recommended by manufacturer.
 2. Repair damage to PVC coatings or paint finishes with matching touchup coating recommended by manufacturer.

3.8 PAYMENT

- A. Lump sum price for Electrical Construction – Lighting Complete covers all items of work in this Special Provision including furnishing labor, materials, tools, equipment, and incidentals required to complete the work.

END OF SECTION

State Road and Tollway Authority (SRTA), State of Georgia

SPECIAL PROVISION

Section 999 – Electrical Construction – Lighting Complete

Section 262726 – Wiring Devices

PART 1 - GENERAL

1.1 RELATED DOCUMENTS

- A. Drawings and general provisions of the Contract, including General and Supplementary Conditions and Division 01 Specification Sections, apply to this Section.

1.2 SUMMARY

- A. Section Includes:
1. Straight-blade convenience, hospital-grade, isolated-ground, and tamper-resistant receptacles.
 2. GFCI receptacles.
 3. Twist-locking receptacles.
 4. Wall switch sensor light switches with dual technology sensors.
 5. Wall plates.

1.3 DEFINITIONS

- A. Abbreviations of Manufacturers' Names:
1. Cooper: Cooper Wiring Devices; Division of Cooper Industries, Inc.
 2. Hubbell: Hubbell Incorporated: Wiring Devices-Kellems.
 3. Leviton: Leviton Mfg. Company, Inc.
 4. Pass & Seymour: Pass& Seymour/Legrand.
- B. BAS: Building automation system.
- C. EMI: Electromagnetic interference.
- D. GFCI: Ground-fault circuit interrupter.
- E. Pigtail: Short lead used to connect a device to a branch-circuit conductor.
- F. RFI: Radio-frequency interference.
- G. SPD: Surge protective device.

- H. UTP: Unshielded twisted pair.

1.4 ACTION SUBMITTALS

- A. **Product Data:** For each type of product.
- B. **Shop Drawings:** List of legends and description of materials and process used for premarking wall plates.
- C. **Samples:** One for each type of device and wall plate specified, in each color specified.

1.5 INFORMATIONAL SUBMITTALS

- A. Field quality-control reports.

1.6 CLOSEOUT SUBMITTALS

- A. **Operation and Maintenance Data:** For wiring devices to include in all manufacturers' packing-label warnings and instruction manuals that include labeling conditions.

1.7 MAINTENANCE MATERIAL SUBMITTALS

- A. Furnish extra materials that match products installed and that are packaged with protective covering for storage and identified with labels describing contents.

PART 2 - PRODUCTS

2.1 GENERAL WIRING-DEVICE REQUIREMENTS

- A. **Wiring Devices, Components, and Accessories:** Listed and labeled as defined in NFPA 70, by a qualified testing agency, and marked for intended location and application.
- B. Comply with NFPA 70.
- C. Devices that are manufactured for use with modular plug-in connectors may be substituted under the following conditions:
 1. Connectors shall comply with UL 2459 and shall be made with stranding building wire.
 2. Devices shall comply with the requirements in this Section.
- D. **Devices for Owner-Furnished Equipment:**
 1. Receptacles: Match plug configurations.
 2. Cord and Plug Sets: Match equipment requirements.
- E. **Source Limitations:** Obtain each type of wiring device and associated wall plate from single source from single manufacturer.

2.2 STRAIGHT-BLADE RECEPTACLES

- A. Duplex Convenience Receptacles: 125 V, 20 A; comply with NEMA WD 1, NEMA WD 6 Configuration 5-20R, UL 498, and FS W-C-596.
1. Cooper: Cooper Wiring Devices; Division of Cooper Industries, Inc.
 2. Hubbell: Hubbell Incorporated: Wiring Devices-Kellems.
 3. Leviton: Leviton Mfg. Company, Inc.
 4. Pass & Seymour: Pass& Seymour/Legrand.

2.3 GFCI RECEPTACLES

- A. General Description:
1. 125 V, 20 A, straight blade, non-feed-through type.
 2. Comply with NEMA WD 1, NEMA WD 6 Configuration 5-20R, UL 498, UL 943 Class A, and FS W-C-596.
 3. Include indicator light that shows when the GFCI has malfunctioned and no longer provides proper GFCI protection.
- B. Duplex GFCI Convenience Receptacles:
1. Cooper: Cooper Wiring Devices; Division of Cooper Industries, Inc.
 2. Hubbell: Hubbell Incorporated: Wiring Devices-Kellems.
 3. Leviton: Leviton Mfg. Company, Inc.
 4. Pass & Seymour: Pass& Seymour/Legrand.

2.4 TWIST-LOCKING RECEPTACLES

- A. Twist-Lock, Single Convenience Receptacles: 125 V, 20 A; comply with NEMA WD 1, NEMA WD 6 Configuration L5-20R, and UL 498.
1. Cooper: Cooper Wiring Devices; Division of Cooper Industries, Inc.
 2. Hubbell: Hubbell Incorporated: Wiring Devices-Kellems.
 3. Leviton: Leviton Mfg. Company, Inc.
 4. Pass & Seymour: Pass& Seymour/Legrand.

2.5 WALL SWITCH SENSOR LIGHT SWITCH, DUAL TECHNOLOGY

1. Cooper: Cooper Wiring Devices; Division of Cooper Industries, Inc.
 2. Hubbell: Hubbell Incorporated: Wiring Devices-Kellems.
 3. Leviton: Leviton Mfg. Company, Inc.
 4. Pass & Seymour: Pass& Seymour/Legrand.
- B. Description: Switchbox-mounted, combination lighting-control sensor and conventional switch lighting-control unit using dual technology.
1. Connections: Provisions for connection to BAS.
 2. Connections: Hard wired.
 3. Connections: Wireless.
 4. Rated 960 W at 120-V ac for tungsten lighting, 10 A at 120-V ac or 10 A at 277-V ac for fluorescent or LED lighting, and 1/4 hp at 120-V ac.
 5. Integral relay for connection to BAS.
 6. Adjustable time delay of five minutes.
 7. Able to be locked to Automatic-On mode.

8. Automatic Light-Level Sensor: Adjustable from 2 to 200 fc.
9. Comply with NEMA WD 1, UL 20, and FS W-S-896.

2.6 WALL PLATES

- A. Single and combination types shall match corresponding wiring devices.
 1. Plate-Securing Screws: Metal with head color to match plate finish.
 2. Material for Unfinished Spaces: Galvanized steel.
 3. Material for Damp Locations: Thermoplastic with spring-loaded lift cover, and listed and labeled for use in wet and damp locations.
- B. Wet-Location, Weatherproof Cover Plates: NEMA 250, complying with Type 3R, weather-resistant, thermoplastic with lockable cover.

2.7 FINISHES

- A. Device Color:
 1. Wiring Devices Connected to Normal Power System: White unless otherwise indicated or required by NFPA 70 or device listing.
- B. Wall Plate Color: For plastic covers, match device color.

PART 3 - EXECUTION

3.1 INSTALLATION

- A. Comply with NECA 1, including mounting heights listed in that standard, unless otherwise indicated.
- B. Coordination with Other Trades:
 1. Protect installed devices and their boxes. Do not place wall finish materials over device boxes and do not cut holes for boxes with routers that are guided by riding against outside of boxes.
 2. Keep outlet boxes free of plaster, drywall joint compound, mortar, cement, concrete, dust, paint, and other material that may contaminate the raceway system, conductors, and cables.
 3. Install device boxes in brick or block walls so that the cover plate does not cross a joint unless the joint is troweled flush with the face of the wall.
 4. Install wiring devices after all wall preparation, including painting, is complete.
- C. Conductors:
 1. Do not strip insulation from conductors until right before they are spliced or terminated on devices.
 2. Strip insulation evenly around the conductor using tools designed for the purpose. Avoid scoring or nicking of solid wire or cutting strands from stranded wire.

3. The length of free conductors at outlets for devices shall meet provisions of NFPA 70, Article 300, without pigtails.
4. Existing Conductors:
 - a. Cut back and pigtail, or replace all damaged conductors.
 - b. Straighten conductors that remain and remove corrosion and foreign matter.
 - c. Pigtailing existing conductors is permitted, provided the outlet box is large enough.

D. Device Installation:

1. Replace devices that have been in temporary use during construction and that were installed before building finishing operations were complete.
2. Keep each wiring device in its package or otherwise protected until it is time to connect conductors.
3. Do not remove surface protection, such as plastic film and smudge covers, until the last possible moment.
4. Connect devices to branch circuits using pigtails that are not less than 6 inches in length.
5. When there is a choice, use side wiring with binding-head screw terminals. Wrap solid conductor tightly clockwise, two-thirds to three-fourths of the way around terminal screw.
6. Use a torque screwdriver when a torque is recommended or required by manufacturer.
7. When conductors larger than No. 12 AWG are installed on 15- or 20-A circuits, splice No. 12 AWG pigtails for device connections.
8. Tighten unused terminal screws on the device.
9. When mounting into metal boxes, remove the fiber or plastic washers used to hold device-mounting screws in yokes, allowing metal-to-metal contact.

E. Receptacle Orientation:

1. Install ground pin of vertically mounted receptacles down, and on horizontally mounted receptacles to the right.
2. Install hospital-grade receptacles in patient-care areas with the ground pin or neutral blade at the top.

F. Device Plates: Do not use oversized or extra-deep plates. Repair wall finishes and remount outlet boxes when standard device plates do not fit flush or do not cover rough wall opening.

G. Dimmers:

1. Install dimmers within terms of their listing.
2. Verify that dimmers used for fan-speed control are listed for that application.
3. Install unshared neutral conductors on line and load side of dimmers according to manufacturers' device listing conditions in the written instructions.

H. Arrangement of Devices: Unless otherwise indicated, mount flush, with long dimension vertical and with grounding terminal of receptacles on top. Group adjacent switches under single, multigang wall plates.

I. Adjust locations of floor service outlets and service poles to suit arrangement of partitions and furnishings.

3.2 GFCI RECEPTACLES

- A. Install non-feed-through-type GFCI receptacles where protection of downstream receptacles is not required.

3.3 IDENTIFICATION

- A. Comply with Section 260553 "Identification for Electrical Systems."
- B. Identify each receptacle with panelboard identification and circuit number. Use hot, stamped, or engraved machine printing with black-filled lettering on face of plate, and durable wire markers or tags inside outlet boxes.

3.4 FIELD QUALITY CONTROL

- A. Test Instruments: Use instruments that comply with UL 1436.
- B. Test Instrument for Convenience Receptacles: Digital wiring analyzer with digital readout or illuminated digital-display indicators of measurement.
- C. Perform the following tests and inspections with the assistance of a factory-authorized service representative]:
- D. Tests for Convenience Receptacles:
 - 1. Line Voltage: Acceptable range is 105 to 132 V.
 - 2. Percent Voltage Drop under 15-A Load: A value of 6 percent or higher is unacceptable.
 - 3. Ground Impedance: Values of up to 2 ohms are acceptable.
 - 4. GFCI Trip: Test for tripping values specified in UL 1436 and UL 943.
 - 5. Using the test plug, verify that the device and its outlet box are securely mounted.
 - 6. Tests shall be diagnostic, indicating damaged conductors, high resistance at the circuit breaker, poor connections, inadequate fault current path, defective devices, or similar problems. Correct circuit conditions, remove malfunctioning units and replace with new ones, and retest as specified above.
- E. Wiring device will be considered defective if it does not pass tests and inspections.
- F. Prepare test and inspection reports.

3.5 PAYMENT

- A. Lump sum price for Electrical Construction – Lighting Complete covers all items of work in this Special Provision including furnishing labor, materials, tools, equipment, and incidentals required to complete the work.

END OF SECTION

State Road and Tollway Authority (SRTA), State of Georgia

SPECIAL PROVISION

Section 009 – Miscellaneous Construction On-Site Decorative Signage

PART 1 - GENERAL

1.01 SUMMARY

- A. Furnish and install Decorative Sign Assembly as shown on the plans and details.
- B. The term "Decorative Sign Assembly" means the complete assemblage of pole, foundation, sign, frame, finial, decorative pole base, sign anchoring, parts, equipment and miscellaneous components, erected as shown on the plans and in accordance with these specifications forming a complete and independent Sign unit.
- C. Components shall be from a single manufacturer.
- D. Related Work:
 1. Section 03 30 00 - Cast-in-Place Concrete
 2. Metal Fabrications

1.02 GENERAL REQUIREMENTS

- A. All decorative sign materials furnished by the contractor shall be new and shall conform to the applicable requirements of MUTCD.
- B. Shop Drawings: Provide 3 sets of drawings representing each sign type. It sign shall include the decorative pole, decorative pole base, foundation, anchoring detail, sign, frame, finial, sign anchoring attachments, parts and hardware.

1.03 REFERENCES

- A. Standards of the following as referenced:
 1. Aluminum Association (AA).
 2. American National Standards Institute (ANSI).
 3. American Society for Testing and Materials (ASTM).
 4. Manual Uniform Traffic Control Device (MUTCD)

1.04 SYSTEM DESCRIPTION

- A. Design criteria: Design to resist wind loads 125 MPH when installed in accord with reviewed shop drawings and installation instructions.

1.05 SUBMITTALS

A. Product Data:

1. Manufacturer's provide statement regarding compliance with QUALITY ASSURANCE.
2. Manufacturer's product literature indicating units and designs selected.
3. Maintenance data and cleaning requirements for exterior surfaces.

B. Shop Drawings:

1. Prior to construction of the items outlined in the plans and details, the Contractor shall prepare and submit final construction "Shop Drawings" for review and approval by the Owner and Designer. Any deviation from the basic design format, details or materials specified must be approved by the Owner's representative.
2. Submit Shop Drawings including design calculations of registered professional engineer, licensed to practice in the state of Georgia, covering all members, connections (welds, bolts, etc.) and footings, indicating such meets the Design Specifications for Sign Structures stress requirements and dead load deflection tolerances. Indicate mounting details for all sign types larger than one square foot of surface area wall surface or substrate. Wind load designs shall meet the requirements of the American Society of Civil Engineer's standard #ASCE 7-98 for computing sign structure wind loads and any local standards whichever is greater.
3. Shop drawings shall include in addition to the items listed below complete details and schedules for fabrication and shop assembly of members, and details, schedules, procedures, and diagrams showing sequence of erection. Do not use reproductions of the Contract Documents for shop drawings.
4. Shop Drawings shall indicate and illustrate:
 - a. Sign Materials, Sizes, Configurations
 - b. Construction Details and Processes
 - c. Fastening Materials and Devices, Applicable Substrate Mountings
 - d. Locations of Connections
 - e. Specifically indicate tolerances required from other sections for base mounting modules
 - f. Color Specifications and Finishes
 - g. Typography Identification
 - h. Typography Layouts for all sign faces including plaques
 - i. Details of coordination with other trades
 - j. Assembly Details
 - k. Installation Details
 - l. Provide Artwork for Special Graphics
 - m. Furnish templates for anchor locations
 - n. Wind and Load Calculations + Signed Engineered Drawings (Engineer Registered In The State of Georgia)
5. Upon completion of the project, the Sign Contractor shall submit final "as-built" Shop Drawings to the Owner & Designer in a printed & electronic format (Adobe Acrobat).

C. Material Samples:

1. Samples of all materials to be used in the construction and installation of the graphics and signage program shall be submitted for review and approval prior to purchasing of materials for the work. This would include materials specified and those recommended by the Contractor or as an approved equal.
2. Samples to be submitted include but are not limited to:
 - a. Sheet Materials Such As Aluminum, Acrylic, Photopolymer, Brass, Bronze, Etc.

- b. Plastic Laminate.
- c. Mechanical Fasteners.
- d. All extrusions to be used in the work (Steel, Aluminum, etc.)
- e. vinyl films.

D. Color and Finish Samples:

1. Samples of all color/finishes specified within the contract documents shall be submitted to the Owner or Owner's Representative for approval prior to application. All color and finish samples shall be clearly identified and labeled using the same color designation used by the Designer.
2. All paint color samples shall be submitted on .063" sheet aluminum, 8-1/2" x 11", three hole punched for insertion into a standard three ring binder. Three (3) of each color shall be submitted for review and approval.
3. All finish samples shall be submitted in the material specified (i.e. Aluminum, etc), approximate thickness shall be .063". The sample shall be 8-1/2" x 11" and shall be three hole punched for insertion into a standard three ring binder. Three (3) of each finish sample shall be submitted for review and approval.
4. All vinyl films shall be submitted in an 8-1/2" x 11" format and shall be three hole punched for insertion into a standard three ring binder. Three (3) samples of each color shall be submitted for review and approval.

E. Hardware Items: Submit samples of each type of anchor, insert or other fastener used in the project.

F. Product Data: The selected Contractor shall submit along with the Shop Drawing submittal, manufacturer's product data for all materials being used or proposed for use in the production and/or installation of the project.

G. Scheduling:

Submit the final schedule for construction of work and installation within ten (10) days of sample approvals. Indicate dates of completion for prototypical units for approval, dates of partial deliveries and total completion. Dates given shall be consistent with the time requirements submitted with the bid.

H. Templates: The Sign Contractor shall submit quarter size graphics templates showing the size, spacing, and positioning of all graphic components for review and approval by the Owner or Owner's Representative prior to production or application of the graphics.

I. Maintenance Instructions:

1. The Sign Contractor shall submit cleaning and maintenance instructions for sign type produced as a part of this project.
2. Instructions shall include recommended cleaning materials and frequency as well as alert notices for cleaning agents or processes which will damage the graphics.

1.06 QUALITY CRITERIA

A. The work performed under this contract shall, where applicable, be in accordance with the most current version of the following standard specifications unless otherwise specified:

1. Aluminum Association (AA) "Standards for Aluminum Mill Products", "Designation for Aluminum Finishes", and Standard for Anodically Coated Aluminum Alloy for Architectural Applications".
2. American Iron & Steel Institute (AISI)
3. American National Standards Institute (ANSI)
4. American Society for Testing Materials (ASTM)
5. Underwriters Laboratories (UL)

6. Concrete Reinforcing Steel Institute (CRSI)
7. Manual of Uniform Traffic Control Devices (MUTCD)
8. National Electrical Code (NEC)
9. Americans With Disabilities Act (ADA)
10. National Fire Protection Association – Life Safety Code (NFPA)
11. Manual Uniform Traffic Control Device (MUTCD)

- B. The Sign Contractor shall be familiar with all Federal, State and Local laws, ordinances, rules and regulations that may affect the work to be performed in this document. Ignorance of the aforementioned on the part of the Sign Contractor shall in no way waive responsibility for performing the work within them.

1.07 JOB CONDITIONS

- A. Field Verification of Existing Conditions and Dimensioning: Take field measurements to determine exact sizes prior to submittal of shop drawings and production of signage. Indicate exact sizes and existing field conditions for mounting details and all other information on shop drawings.
- B. Store materials to be installed where directed by the Owner.
- C. Maintain neat, clean conditions in working areas; remove trash, rags and waste materials at end of each day's work. Protect materials against damage or defacement.
- D. Close any open containers at end of day's work. Leave no materials open.
- E. Acrylic and other glazing materials or finish materials with or requiring protective wrapping shall only have this protection removed as required during fabrication and installation and once the area is clear of work or activities which might cause damage to the installed work. Care shall be taken in handling surfaces and products to prevent scratching, chipping, or cracking.
- F. Protection: Cover finished work of other trades and/or the existing property of the Owner and/or prefinished items and surfaces.
- G. Store materials a minimum of 4" above ground on framework or blocking and cover with protective waterproof covering. Provide air circulation and ventilation. Store in dry, conditioned space.
- H. Environmental Requirements:
1. Comply with manufacturer's recommendations regarding environmental conditions under which materials/coatings may be applied.
 2. No materials/coatings shall be applied in spaces where dust is being generated which may affect the finish surface or durability of the product.
 3. After the contract has been awarded, the Sign Contractor must conduct an on-site inspection of all existing conditions as they relate to the location of planned graphics and signage. This inspection should be conducted with an Owner's Representative.
 4. The Sign Contractor shall field verify all conditions and dimensions shown on the Design Specification Drawings. Any conflict between the dimensions shown in the Design Specification Drawings and field verified conditions shall be brought to the attention of Owner's Representative in writing for verification and/or resolution. It is the Sign Contractor's ultimate responsibility to manufacture the Signage and Graphics to meet the on-site conditions at the time of installation.

1.08 SEQUENCING AND SCHEDULING

- A. Coordinate:
 1. Installation with adjacent finish materials not destroying adjacent surfaces.
 2. With other sections for cast-in or built-in anchors and mounting hardware required in work accomplishes in other sections.

1.09 WARRANTY

- A. A minimum one-year warranty must be submitted to the Owner and a copy submitted to the Designer to cover the following:
- B. All fabrication shall be warranted against defects resulting from the use of inferior materials, equipment, or poor workmanship. If, within the one-year period, repair and/or compensation are required that result from these problems, the Sign Contractor shall promptly:
 1. Correct all fabrication defects;
 2. Make compensation for all damages to the site that result from the use of inferior materials, equipment or workmanship;
 3. Be liable for all personal injuries that result from the use of inferior materials, equipment or workmanship.
- C. A minimum one-year warranty must be submitted for the installation of the graphics and signage.
 1. The warranty is to state that the Sign Contractor is responsible for a safe, sound, secure and as vandal-proof as possible graphics/signage installation. If, within the one-year period, repairs and/or compensation are needed that result from unsafe or unsound sign installation, or lack of proper engineering, the Sign Contractor shall promptly:
 - a. Correct the installation to make it safe, sound and secure;
 - b. Compensate for all damages to the site that result from unsafe, unsound, or insecure installation;
 - c. Be liable for all personal injuries that result from unsafe, unsound or insecure installation.
- D. A minimum one-year warranty must be submitted on all painted surfaces, finishes and sign panel graphics. This warranty should cover peeling, cracking, blistering, discoloring, and all other abnormal occurrences regarding the painted surfaces, finishes, or sign panel fabrication / application.
- E. A minimum one-year warranty must be submitted on material life and a warranty against cracking, peeling and discoloring of all vinyl graphics. The guarantee period for each item above begins on the date that a written project approval or final payment is received by the Sign Contractor from the Owner or Owner's Representative.

1.010 GRAPHICS, ARTWORK AND ELECTRONIC FILES

- A. For graphics specified in the drawings, the designer shall only furnish graphic design electronic files in a format that already exists or was created during designing the project. Files are likely to have been prepared in graphic design industry standard computer software on PC platform computer hardware. The contract document drawings and layouts for the work shall not be transferred or transmitted to the contractor. Contractors are responsible for obtaining any necessary fonts and software that are used in the work or that will enable the contractor to open any files requested from the designer.

PART 2 - PRODUCTS**2.01 GENERAL**

- A. The design intent for this project is that the Sign Contractor shall use, whenever, possible, standard size and readily available materials to reduce the cost of manufacturing the contents of this package. All materials shall be of the highest quality and shall meet all industry standards.
- B. All materials used in the construction and installation of this project shall be non-corrosive.

2.02 ALUMINUM POLE

- A. 3" OD Extruded Smooth Aluminum Pole :
 - 1. Comply with the following industry standards:
 - a. 3" OD
 - b. 2.75" ID
 - c. Min. .125" Wall
 - d. Min. 12' length
- B. Pole Base
 - 1. Model SB-33 Manufactured by Brandon Industries or approved equal
 - a. Two-Piece Cast Aluminum Base for 3" OD Round Pole
 - b. 24" height, 7" Width
- C. Finial
 - 1. Model: FINA3 Manufactured by Brandon Industries or approved equal
 - 2. Cast Aluminum, Acorn Finial for 3" OD
 - 3. Height: 6.75", Width 3.125"
- D. Sign Trim / Frame
 - 1. Cast aluminum sign trim to fit sign panel dimensions as shown on the plans and details.
- E. Sign Panel
 - 1. Aluminum panels, signs must meet MUTCD standards for sheeting requirements.
 - 2. Refer to plans for sizes and types of signs.
 - 3. Shop drawings for Custom sign graphic panels must be approved prior to ordering.

2.03 FASTENERS & HARDWARE

- A. All fasteners used in the production or installation of this project shall be non corrosive, and be installed in a manner that will not create potentially corrosive imperfections in other materials/environments.
- B. All fasteners to be utilized in the manufacturing and installation of this project shall be identified on the shop drawings and samples submitted to the Architect for final review and approval.

PART 3 - EXECUTION**3.01 GENERAL**

- A. Written dimensions shall take precedence over scaled dimensions on all drawings.

- B. If a disagreement is found between the written specifications and/or message schedule and those found on the specification drawings, or within the written specifications themselves, the Sign Contractor shall submit a written notice of the discrepancy to the Designer for clarification. If the discrepancy will affect the bid submittal the written notification shall be submitted at least five days prior to the bid due date so that a clarification notice may be prepared and submitted to all bidders. If the disagreement is discovered at a time such that formal clarification cannot be forwarded to all bidders, then the bidder shall submit the bid based on the written specifications. Written specifications shall take precedence over notes found on the drawings.
- C. The Sign Contractor shall be responsible for the engineering of all signage construction details and signage installation details for the signage being produced as part of this contract. The seal and signature of an engineer registered in the State of Georgia shall be included on all shop drawings along with all calculations related to the approval of engineered details. Neither the Owner, or the Designer shall be held liable for any liability resulting from negligence on the part of the Sign Contractor and/or the Sign Contractor's Engineering Consultant for damage or bodily harm related to signage construction details or installation details.

3.02 CONSTRUCTION AND FABRICATION WORKMANSHIP

A. Aluminum Fabrication:

1. All sign faces are to be smooth and even, free from imperfections and disfiguring caused process such as welding, fasteners, ungrounded welds, "oil-canning", puckering or any other conditions not specifically mentioned herein, prior to application of paint, vinyl, ink, etc.
2. All finish work, unless specified on the drawings, shall be smooth, free from abrasion, tool marks, visible welds, exposed fasteners or similar defects prior to application of paint, vinyl, ink, etc.
3. All corners, reveals, and joints shall be milled to match adjoining pieces and shall be fabricated to match the dimensions indicated in the approved Sign Shop Drawings.
4. No brake bending or forming of the exterior corners of the sign units shall be acceptable unless otherwise noted in the Sign Specification Drawings. All aluminum parts shall be saw cut. All external welds shall be continuous, filled and ground smooth so that the finished seams are not visible in the finished product.
5. Internal welds shall be structurally sound and eliminate racking.
6. There shall be no bare aluminum in contact with any other metals, woods or concrete. Contact surfaces shall be separated by a heavy body bituminous paint or by a gasket.
7. Seams which must occur in a sign face, shall be filled and finished smooth prior to priming and painting of the finished sign unit. Seams shall not be visible in the finished product and shall be constructed in a manner that will insure that the finished seam will not "crack" or "protrude" over time.

B. Typography & Graphics:

1. The Sign Contractor is responsible for providing or obtaining all symbol artwork used in this project and illustrated in the Symbol Specifications or Specification Drawings. All symbols, to be used in this project must be shown in the submitted shop drawings for approval prior to production.

2. Typefaces and symbols for this project are illustrated in the Typography & Symbol Specifications of this document. The Sign Contractor is responsible for using the exact typefaces and symbols illustrated in the Sign Specification Drawings. If the Sign Contractor is unsure of a typeface's identity or a symbol's details, the Sign Contractor shall consult with the Designer.
3. Silk Screened Graphics
 - a. All photo silk screened graphics shall be sharp, without irregular or serrated edges, and exactly true to letter style or design form.
 - b. All ink applications shall be applied per the manufacturers recommended specifications for the surface on which the ink shall be applied.
 - c. Ink shall not be applied until the preceding coat has dried.
 - d. Application of ink shall be even and consistent without variation in the color. The ink application shall be opaque to avoid "shadowing" from background colors.
 - e. All Silk-screen inks used shall be those specified by the manufacturer for interior or exterior use.
4. Applied Screened Graphics
 - a. All vinyl typography, symbols and graphics shall be precision machine cut utilizing current computer capabilities. Only in exceptional cases is hand cutting of vinyl graphics permitted and must be disclosed at time of bid submittal.
 - b. All vinyl graphics shall be cut sharp and even without serrated edges, and exactly true to the graphics form.
 - c. Vinyl graphics shall be applied per the manufacturer's recommendations. Air bubbles or wrinkles in the finished surface will not be acceptable or approved.
 - d. In situations where the vinyl film is being applied to a painted surface, the Contractor must take precautions to insure that the painted surface has dried thoroughly to prevent damage to the vinyl caused by out-gassing of the curing paint surface.
 - e. All applied vinyl graphics shall be installed per manufacturer's specifications.

C. Color and Finish

1. Refer to the Sign Specification Drawings to determine the colors/materials for each signage or graphic element. Color & Material reference numbers are designated on the Sign Specification Drawings. Refer to the Color Schedule for color designations.
2. Coatings and finishes are to accurately match the colors specified by the Designer and color samples approved per the color submittal process.
3. All coating applications shall be smooth, even and consistently uniform. The cured surface shall have a uniform finish that matches the specified color and finish.
4. Color breaks that occur on the visible portions of the signage or graphics shall be sharp and even without serration or color bleed.
5. All splatters, drips, spills or over sprays shall be removed or corrected prior to final inspection by the Designer.
6. Exact identification of all coatings and finishes shall be identified in the Shop Drawing submittal and shall indicate the method of application.
7. All finished coatings and finishes shall receive a protective clear coat to aid in the durability of the finish as well as aid in the ease of cleaning.
8. All colors and finishes shall be applied per the manufacturer's specifications or recommendations for the material to receive the coating.

3.03 PRODUCT INSPECTION

- A. Prior to shipment to site for installation, all finished and completed graphics and signage shall be inspected in the contractor's shop by the Designer. All signage shall be completed, labeled and displayed in a manner that will provide for an expeditious review by the Designer.

3.04 LABELING, STORAGE, DELIVERY

- A. All products shall be stored in protective packaging to prevent damage. Any completed product must be stored in a bonded storage facility until installation.
- B. All sign products shall be packaged for protection from damage during shipment to the project site. All products shall be clearly labeled for easy identification while in the protective packaging. Identification shall include sign type number and sign location number per the contract drawings and plans.
- C. The Contractor is responsible for any damage which occurs during the shipment of graphics and signage related products to the project site.

3.05 INSPECTION OF SITE

- A. Surfaces to receive graphics and signage shall be free from defects and imperfections that would prevent an acceptable installation.
- B. Commencement of work in any space shall constitute acceptance by the Contractor of surfaces to receive signage as being in a satisfactory condition to permit an acceptable installation. If the Contractor's inspection of the application surfaces discloses unsatisfactory conditions, he shall notify the Designer in writing and await further instruction; otherwise, no claims will be considered for unsatisfactory work due to real or alleged faulty surfaces.

3.06 INSTALLATION, ERECTION, APPLICATION

- A. Perform work in accordance with the plans and details.
- B. Install decorative sign assembly in accordance with manufacturer's instructions at locations indicated on the drawings. Install decorative signage assembly plumb, and anchor decorative sign assembly securely in place.
- C. Minor damages to finish shall be repaired in accordance with the manufacturer's instructions and as approved by the Engineer. Remove and replace damaged components that cannot be successfully repaired as determined by the Engineer.
- D. If the Sign Contractor does not feel it will be possible to meet the final completion date due to the delay by the Owner's review of shop drawings, a written report must be submitted to The Owner and the Owner/Owner's Construction Manager outlining the specific areas of concern. This report must be filed at least two weeks prior to the installation deadline in order to avoid penalties being levied against the Sign Contractor.
- E. Signage locations: Prior to installation, the Sign Contractor and an Owner representative shall conduct a final walk through to stake out all sign locations.
- F. The Contractor is responsible for providing all materials and equipment necessary to properly locate and document the exact sign placement and orientation in the field.

1. Marking materials shall not disfigure or permanently mar the installation environment and must be removed immediately following signage installation.
 2. Sign markers shall indicate the Sign Location Number, Sign Type Number, and Sign Face if applicable.
- G. If the Sign Contractor elects to sub-contract graphics/signage installation, the Sign Contractor must have a Project Manager on-site at all times during the installation process.
- H. The Sign Contractor shall at all times guard from damage or loss, the areas around each sign, and shall replace or repair any loss or damage. The Owner may withhold payment or make such deductions as deemed necessary to insure reimbursement for loss or damage to property through negligence of the Sign Contractor or his agents. The Sign Contractor shall at all times guard against injury to persons within the sign facility site and the sign site.
- I. During the installation phase of the project, the Sign Contractor shall structure the work and provide adequate and qualified personnel to insure the least amount of inconvenience and interruption of normal daily activities of adjacent property owners/residents. Working hours shall have the approval of the Owner.
- J. All debris relating to signage installation must be removed from the areas of the project after completion of the installation phase.
- K. The Owner or an Owner Representative will conduct a post installation inspection of the sign units only after all signage and graphics are installed. To prevent damage to the sign units between installation and final review the Sign Contractor must take precautions to protect the individual sign units. In addition, the Sign Contractor must provide The Owner with a detailed installation schedule and completion time so that the final review may be conducted in a timely manner. Liability for sign units damaged between installation and final review shall be resolved between the Sign Contractor and the subcontractor for the sign if a subcontractor is used. Otherwise, all cost shall be borne by the Sign Contractor.
- L. Timing of Signage Installation / Hours of Installation shall be at the direction of the Owner.

3.03 PROTECTION

- A. Work in progress shall be protected at all times from staining, scratching, chipping or other damage.
- B. Provide final protection in a manner acceptable to the fabricator and installer until Date of Substantial Completion.
- C. Acrylic shall be removed from protective wrapping only as required to facilitate installation. Care shall be taken in handling acrylic sheets to prevent scratching, chipping or crazing.

3.04 CLEANING AND ADJUSTMENTS

- A. Clean exposed surfaces promptly after completion of installation in accordance with manufacturer's written cleaning instructions.
- B. Remove and replace damaged signage and graphics with new graphics free of defects.
- C. Clean exposed metal work with cleanser recommended by the manufacturer. Do not use harsh chemicals or abrasive matter in cleaning signage. Surfaces with stains or imperfections, which cannot be corrected or cleaned, shall be replaced to the satisfaction of the Owner without additional cost to the Owner.

- D. Signs shall be free of tape, packing paper, dirt smudges and other foreign materials.
- E. All installed signage and graphics shall be left level and fully cleaned on the Date of Substantial completion by the Contractor.

3.05 EXTRA PARTS

- A. Loose parts of sign assemblies, and/or special tools shall be itemized and supplied to the Owner upon completion of the project.

3.06 PAYMENT

- A. Payment for the decorative signage shall be lump sum and shall include all items such as concrete footing, pole, finial, sign frame, sign aluminum panels, finishes, graphics, sign attachment to pole, anchoring and installation of sign assembly. The payment is full compensation for all excavation, furnishing and installation of decorative signage, materials, disposal of materials, cost of furnishing all tools, safety devices, labor, equipment, and all other necessary items to complete the work.

END OF SECTION

State Road and Tollway Authority (SRTA), State of Georgia

SPECIAL PROVISION

Section 754 – Monument / Sculpture Entry Monument Signage with LED Lighting

PART 1 - GENERAL

1.01 SUMMARY

- A. Section includes general specifications for the illuminated entry monument signage. Sign to be constructed in accordance with this specification, in conformity with the form, dimensions, and design shown on the plans, and to the lines and grades established by the Engineer.
- B. Section includes cast-in-place concrete, including formwork, reinforcement, concrete materials, metal and aluminum panels/lettering, placement procedures, LED lighting, CMS signage conduit installation, and finishes. CMS signage to be installed by others.
- C. Components shall be from a single manufacturer.
- D. Related Work:
 1. Section 03 30 00 - Cast-in-Place Concrete
 2. GDOT Specification Section 511 - Reinforcement Steel
 3. Metal Fabrications
 4. Exterior Lighting (LED)

1.02 GENERAL REQUIREMENTS

- A. The contents of this document have been generated to define the parameters and general specifications by which the graphics and signage described must be constructed / fabricated. The selected Contractor remains responsible for details and accuracy, for conforming and correlating all quantities and dimensions, for fabrication processes, for safe and sound techniques of assembly/installation, for performing his work in a safe manner and for complying with all contractual agreements. Furthermore, the Contractor shall review the use, details, and method of installation for all graphics illustrated in this package and shall disclose to the Designer any and all deviations from his recommended use and method of installation and shall also disclose to the Designer his recommendations for the manufacturing and method of installation of the signage illustrated to achieve the intended purpose and result. Such disclosures shall be made with submittal of a bid for this project.
- B. **PROPRIETARY RIGHTS:** All proprietary rights in the subject matter of the material in the accompanying drawings, descriptions and specifications, and rights to the material itself are reserved to the submitter's use. Reproduction, loaning or transmitting of the descriptions, specifications or drawings without consent in writing of the State Road and Tollway Authority (SRTA) is not permitted. Acceptance of the specifications and drawings denotes acceptance of these conditions.

- C. Any image reproduction showing the completed product of this project in any marketing media, shall have written consent from the State Road and Tollway Authority (SRTA) and the sign Contractor shall identify and give credit to ATKINS as the Designer.
- D. All referenced manufacturer's requirements and specifications and nationally recognized and accepted standards & specifications shall be the latest edition unless specified otherwise and shall be used as they are applicable for products and craftsmanship incorporated in the Contract Drawings and this Section only. The references to these standards and specifications do not imply acceptance of any and all products described in the standards and specifications.
- E. The manufacturer shall review the use, details, and provide method of installation of his product to the Designer and all deviations from his recommended use and method of installation and shall also disclose to the Designer his recommendations for the use and method of installation of his product to achieve the intended purpose and result. Such disclosures shall be made within the time stipulated for submission of shop drawings.
- F. The Sign Contractor is responsible for all appropriate insurance coverage, design engineering, fabrication, coordination of sub-contractors, installation and service of the graphics and signage as per the contract documents. The seal of an engineer registered in the State of Georgia shall be affixed to shop drawings for all sign types that are to be engineered as required by any Federal, State or Local laws and/or as specified in the Sign Type Construction and Installation Specifications found in this document.
- G. The Sign Contractor shall be responsible for notifying and coordinating with the Local Utility companies to mark any electrical lines, water lines, etc. prior to locating signs and digging.
- H. Each Monday, throughout the duration of signage production and installation process, the Sign Contractor shall submit a Project Status Report to the Owner's Representative and the Designer, briefly describing the prior week's activities and progress, and the anticipated progress to be accomplished in the coming week. These reports shall also be used as a Request for Information and as a reminder of submittal and review dates.

1.03 REFERENCES

- A. Standards of the following as referenced:
 1. Aluminum Association (AA).
 2. American National Standards Institute (ANSI).
 3. American Society for Testing and Materials (ASTM).
 4. Underwriters' Laboratories, Inc. (UL).

1.04 SYSTEM DESCRIPTION

- A. Design criteria: Design to resist wind loads 125 MPH when installed in accord with reviewed shop drawings and installation instructions.

1.05 SUBMITTALS

- A. Product Data:
 1. Manufacturer's provide statement regarding compliance with QUALITY ASSURANCE.
 2. Manufacturer's product literature indicating units and designs selected.
 3. Maintenance data and cleaning requirements for exterior surfaces.
 4. Underwriters' Laboratories, Inc. (UL).

- B. Shop Drawings:**
1. The entry monument sign detail has been generated and defined as the "DESIGN INTENT ONLY" and are not to be considered or used for construction purposes. Prior to construction of the items outlined in this package, the Contractor shall prepare and submit final construction "Shop Drawings" for review and approval by the Owner and Designer. Any deviation from the basic design format, details or materials specified must be approved by the Owner's representative.
 2. Submit Shop Drawings including design calculations of registered professional engineer, licensed to practice in the state of Georgia, covering all members, connections (welds, bolts, etc.) and footings, indicating such meets the Design Specifications for Sign Structures stress requirements and dead load deflection tolerances. Indicate mounting details for all sign types larger than one square foot of surface area wall surface or substrate. Wind load designs shall meet the requirements of the American Society of Civil Engineer's standard #ASCE 7-98 for computing sign structure wind loads and any local standards whichever is greater.
 3. Shop drawings shall include in addition to the items listed below complete details and schedules for fabrication and shop assembly of members, and details, schedules, procedures, and diagrams showing sequence of erection. Do not use reproductions of the Contract Documents for shop drawings.
 4. Shop Drawings shall indicate and illustrate:
 - a. Sign Materials, Sizes, Configurations
 - b. Construction Details and Processes
 - c. Fastening Materials and Devices, Applicable Substrate Mountings
 - d. Locations of Connections
 - e. Specifically indicate tolerances required from other sections for base mounting modules
 - f. Color Specifications and Finishes
 - g. Typography Identification
 - h. Typography Layouts for all sign faces including plaques
 - i. Details of coordination with other trades
 - j. Assembly Details
 - k. Installation Details
 - l. Provide Artwork for Special Graphics
 - m. Furnish templates for anchor locations
 - n. Wind and Load Calculations + Signed Engineered Drawings (Engineer Registered In The State of Georgia)
 5. Upon completion of the project, the Sign Contractor shall submit final "as-built" Shop Drawings to the Owner & Designer in a printed & electronic format (Adobe Acrobat).
- C. Material Samples:**
1. Samples of all materials to be used in the construction and installation of the graphics and signage program shall be submitted for review and approval prior to purchasing of materials for the work. This would include materials specified and those recommended by the Contractor or as an approved equal.
 2. Samples to be submitted include but are not limited to:
 - a. Sheet Materials Such As Aluminum, Acrylic, Photopolymer, Brass, Bronze, Etc.
 - b. Plastic Laminate.
 - c. Mechanical Fasteners.
 - d. All extrusions to be used in the work (Steel, Aluminum, etc.)
 - e. 3M Brand Scotchlite and Scotchcal vinyl films.
- D. Color and Finish Samples:**
1. Samples of all color/finishes specified within the contract documents shall be submitted to the Owner or Owner's Representative for approval prior to application. All color and finish samples shall be clearly identified and labeled using the same color designation used by the Designer.

2. All paint color samples shall be submitted on .063" sheet aluminum, 8-1/2" x 11", three hole punched for insertion into a standard three ring binder. Three (3) of each color shall be submitted for review and approval.
 3. All finish samples shall be submitted in the material specified (i.e. Aluminum, etc), approximate thickness shall be .063". The sample shall be 8-1/2" x 11" and shall be three hole punched for insertion into a standard three ring binder. Three (3) of each finish sample shall be submitted for review and approval.
 4. All vinyl films shall be submitted in an 8-1/2" x 11" format and shall be three hole punched for insertion into a standard three ring binder. Three (3) samples of each color shall be submitted for review and approval.
 5. All Silkscreen colors shall be screened onto a sheet of .063 aluminum that has been painted white. Each color shall be screened using the text "COLOR TEST" in 48pt. type.
- E. **Hardware Items:** Submit samples of each type of anchor, insert or other fastener used in the project.
- F. **Product Data:** The selected Contractor shall submit along with the Shop Drawing submittal, manufacturer's product data for all materials being used or proposed for use in the production and/or installation of the project.
- G. **Prototypes:**
1. Once Shop Drawings have been approved, the Sign Contractor shall produce and submit to the Owner or Owner's Representative for approval, full size prototypes of the Entry Monument Sign.
 2. Approved prototypes shall be returned to the sign contractor and use as part of the final product to be installed. Approved prototypes shall set standards for all subsequent fabricated signs.
 3. Scheduling: Submit the final schedule for construction of work and installation within ten (10) days of sample approvals. Indicate dates of completion for prototypical units for approval, dates of partial deliveries and total completion. Dates given shall be consistent with the time requirements submitted with the bid.
- H. **Templates:** The Sign Contractor shall submit quarter size graphics templates showing the size, spacing, and positioning of all graphic components for review and approval by the Owner or Owner's Representative prior to production or application of the graphics.
- I. **Permits:**
1. Any required permits for graphics and signage shall be applied for, obtained and paid for by the Sign Contractor, prior to purchasing materials for the products to be produced.
 2. Original sign permits shall be submitted to the Owner or the Owner's Representative.
- J. **Maintenance Instructions:**
1. The Sign Contractor shall submit cleaning and maintenance instructions for sign type produced as a part of this project.
 2. Instructions shall include recommended cleaning materials and frequency as well as alert notices for cleaning agents or processes which will damage the graphics.

1.06 QUALITY CRITERIA

- A. The work performed under this contract shall, where applicable, be in accordance with the most current version of the following standard specifications unless otherwise specified:
1. Aluminum Association (AA) "Standards for Aluminum Mill Products", "Designation for Aluminum Finishes", and Standard for Anodically Coated Aluminum Alloy for Architectural Applications".
 2. American Iron & Steel Institute (AISI)
 3. American National Standards Institute (ANSI)

4. American Society for Testing Materials (ASTM)
5. Underwriters Laboratories (UL)
6. Concrete Reinforcing Steel Institute (CRSI)
7. Manual of Uniform Traffic Control Devices (MUTCD)
8. National Electrical Code (NEC)
9. Americans With Disabilities Act (ADA)
10. National Fire Protection Association – Life Safety Code (NFPA)

- B. The Sign Contractor shall be familiar with all Federal, State and Local laws, ordinances, rules and regulations that may affect the work to be performed in this document. Ignorance of the aforementioned on the part of the Sign Contractor shall in no way waive responsibility for performing the work within them.

1.07 JOB CONDITIONS

- A. Field Verification of Existing Conditions and Dimensioning: Take field measurements to determine exact sizes prior to submittal of shop drawings and production of signage. Indicate exact sizes and existing field conditions for mounting details and all other information on shop drawings.
- B. Store materials to be installed where directed by the Owner.
- C. Maintain neat, clean conditions in working areas; remove trash, rags and waste materials at end of each day's work. Protect materials against damage or defacement.
- D. Close any open containers at end of day's work. Leave no materials open.
- E. Acrylic and other glazing materials or finish materials with or requiring protective wrapping shall only have this protection removed as required during fabrication and installation and once the area is clear of work or activities which might cause damage to the installed work. Care shall be taken in handling surfaces and products to prevent scratching, chipping, or cracking.
- F. Protection: Cover finished work of other trades and/or the existing property of the Owner and/or prefinished items and surfaces.
- G. Store materials a minimum of 4" above ground on framework or blocking and cover with protective waterproof covering. Provide air circulation and ventilation. Store in dry, conditioned space.
- H. Environmental Requirements:
1. Comply with manufacturer's recommendations regarding environmental conditions under which materials/coatings may be applied.
 2. No materials/coatings shall be applied in spaces where dust is being generated which may affect the finish surface or durability of the product.
 3. After the contract has been awarded, the Sign Contractor must conduct an on-site inspection of all existing conditions as they relate to the location of planned graphics and signage. This inspection should be conducted with an Owner's Representative.
 4. The Sign Contractor shall field verify all conditions and dimensions shown on the Design Specification Drawings. Any conflict between the dimensions shown in the Design Specification Drawings and field verified conditions shall be brought to the attention of Owner's Representative in writing for verification and/or resolution. It is the Sign Contractor's ultimate responsibility to manufacture the Signage and Graphics to meet the on-site conditions at the time of installation.

1.08 SEQUENCING AND SCHEDULING

- A. Coordinate:
 1. Installation with adjacent finish materials not destroying adjacent surfaces.
 2. With other sections for cast-in or built-in anchors and mounting hardware required in work accomplishes in other sections.

1.09 WARRANTY

- A. A minimum two-year warranty must be submitted to the Owner and a copy submitted to the Designer to cover the following:
- B. All fabrication shall be warranted against defects resulting from the use of inferior materials, equipment, or poor workmanship. If, within the two year period, repair and/or compensation are required that result from these problems, the Sign Contractor shall promptly:
 1. Correct all fabrication defects;
 2. Make compensation for all damages to the site that result from the use of inferior materials, equipment or workmanship;
 3. Be liable for all personal injuries that result from the use of inferior materials, equipment or workmanship.
- C. A minimum two-year warranty must be submitted for the installation of the graphics and signage.
 1. The warranty is to state that the Sign Contractor is responsible for a safe, sound, secure and as vandal-proof as possible graphics/signage installation. If, within the two-year period, repairs and/or compensation are needed that result from unsafe or unsound sign installation, or lack of proper engineering, the Sign Contractor shall promptly:
 - a. Correct the installation to make it safe, sound and secure;
 - b. Compensate for all damages to the site that result from unsafe, unsound, or insecure installation;
 - c. Be liable for all personal injuries that result from unsafe, unsound or insecure installation.
- D. A minimum two-year warranty must be submitted on all painted surfaces or photo silk-screened surfaces. This warranty should cover peeling, cracking, blistering, discoloring, and all other abnormal occurrences regarding the painted or silk-screened application.
- E. A minimum five-year warranty must be submitted on material life and a warranty against cracking, peeling and discoloring of all vinyl graphics. The guarantee period for each item above begins on the date that a written project approval or final payment is received by the Sign Contractor from the Owner or Owner's Representative.

1.010 GRAPHICS, ARTWORK AND ELECTRONIC FILES

- A. For graphics specified in the drawings, the designer shall only furnish graphic design electronic files in a format that already exists or was created during the course of designing the project. Files are likely to have been prepared in graphic design industry standard computer software on PC platform computer hardware. The contract document drawings and layouts for the work shall not be transferred or transmitted to the contractor. Contractors are responsible for obtaining any necessary fonts and software that are used in the work or that will enable the contractor to open any files requested from the designer.

1.011 PERMITS

- A. Local jurisdiction sign permits are required for all sign types on this project. Where applicable, the Sign Contractor shall be responsible for procurement and payment of all sign permits.

PART 2 - PRODUCTS

2.01 GENERAL

- A. The design intent for this project is that the Sign Contractor shall use, whenever, possible, standard size and readily available materials to reduce the cost of manufacturing the contents of this package. All materials shall be of the highest quality and shall meet all industry standards.
- B. All materials used in the construction and installation of this project shall be non-corrosive.

2.02 METALS

- A. Aluminum:
 1. Comply with the following industry standards:
 - a. Structural shapes: ASTM B221-83,6061-T6 alloy.
 - b. Extruded bars, rods, shapes and tubes: ASTM B221-83,6063 alloy.
 - c. Extruded pipe: ASTM B429-83, 6063 alloy.
 - d. Flat sheet and plate: ASTM B209-83, 1100, 3003 or 5052 alloy.
 - e. Aluminum castings: ASTM B108-82b for permanent mold castings and B26-82b, Class 25, for sand castings.
 2. Filler metal for welding aluminum shall be the alloy recommended for each application by the manufacturer of the aluminum alloy.
 3. Aluminum shapes shall be cut smooth and straight and shall be de-burred prior to finishing and assembly.
 4. Fasteners shall be 2024 alloy for screws and 6061 for rivets.
 5. Acceptable manufacturers for hard anodic finish:
 - a. Aluminum Company of America
 - b. Kaiser Aluminum
 - c. Reynolds Metal Company
 - d. Or an approved equal
 6. Aluminum for hard anodic finish shall be of the alloy required to produce the specified finish. Temper as recommended by the manufacturer
 7. Use an appropriate alloy for fasteners, screws and rivets.
 8. All sign cabinets shall be fabricated with precision and high standards of quality craftsmanship. All seams, where necessary shall be filled, sanded and finished smooth so they are not visible. All removable panels shall operate smoothly and fit accurately. Polyester (catalyst activated) filler, where used, shall be sanded smoothly and painted to achieve an undetectable smooth effect. All edges shall be sanded and corners slightly rounded. Fasteners shall be hidden, or if visible, shall be countersunk and painted to match the surrounding finish. Flawed or faulty workmanship is subject to rejection by the Owner or Architect and shall be replaced with an acceptable unit.
 9. Minimum aluminum thickness for sign construction shall be .125"minimum unless specified otherwise on the specification drawings.
 10. Finishes: Brushed aluminum panel or stainless steel, concrete panel with applied texture or single slab limestone panel.
- B. Metal Letterforms:
 1. Cast aluminum:

- a. Aluminum association, B443.0 alloy.
- b. Comply with federal specifications AA-A-601D or QQ-A596D.
- c. Aluminum to receive anodic coating: AA514.0 alloy or AA A514.0.
2. Finishes (if specified):
 - a. Fine Satin: Polish with grits of 320 to 400 using peripheral wheelspeed of 7,000 F.P.M.
 - b. Fine Matte: Air blast with 100 to 200 mesh silica sand if darkening is a problem; otherwise aluminum oxide type abrasive. Air pressure 30 to 90 degrees.
 - c. Specular: Polish with grit coarser than 320 followed by buffing with aluminum oxide compound using peripheral wheelspeed of 7,000 F.P.M.
 - d. Painted finishes shall be two-part acrylic polyurethane.
3. Fabricated letters from aluminum shall be heliarc welded in conformance with the American Welding Society and the Aluminum Association's specifications. Metal shall be 3003H14 or 60601 alloy. Thickness shall be as follows:
 - a. .063" aluminum sheet for letters 6" to 24" in capital height.
 - b. .087" aluminum sheet for letters 25" to 72" in capital height.
4. Cut letterforms shall be true to form with no irregularities; remove burrs and rough spots. Sides shall be smooth with saw marks removed, thickness as specified on drawings.
5. Metal letterforms shall be:
 - a. free of all porosity, waves, buckles or warpage;
 - b. have sharp corners, flat faces and accurate profiles;
 - c. be free of burs and rough spots;
 - d. be belt polished to a uniform high lustre finish where specified;
 - e. be filed smooth and without tool;
 - f. be clean and packaged with protective wrapping until installation;
 - g. be mounted using only non-ferrous fasteners or components that rust.

C. Etched Metal Signs:

1. Sign finish: satin, polished or blasted.
2. Recessed graphics and color-filled graphics, see drawings for indications.
3. Surface coating: matte
4. Material: stainless steel, aluminum,.
5. Resource for etched sign production: Kaltech Architectural Signage 123 West 19th Street, New York, NY 10011, tel 800-435-TECH. (or approved equal)

D. Structural Steel:

1. Comply with industry standards for any components, used in fabrication or construction.
2. Paint for all shop coats and field touch-up shall be a compatible industry standard primer.
3. Provide all connections necessary for complete erection. Unless otherwise indicated, shop connections shall be welded.
4. Welding shall be in accordance with the approved welding procedures and AIW Structural Welding Code.
5. Anchor bolts and leveling plates:
 - a. Furnish loose leveling plates for column erection.
 - b. Furnish anchor bolts as indicated to be embedded in concrete, including nuts and washers. Detail anchor bolts such that the minimum projection above the nut after column is in place is one inch.
6. Connections for other work: Coordinate with other trades to provide holes in structural steel for attachment to their work where required. Provide necessary holes if information is received prior to fabrication.

E. Steel Fabrications:

1. This section includes the following metal fabrications:
 - a. Rough hardware.
 - b. Miscellaneous metal trim.
 - c. Metal frame and panel construction.

2. **Structural System Performance:** Design, engineer, fabricate, and install the following metal fabrications to withstand the following structural loads without exceeding the allowable design working stress of the materials involved, including anchors and connections. Apply each load to produce the maximum stress in each respective component of each metal fabrication.
 - a. **Framing Systems:** Capable of withstanding the following loads applied as indicated:
 - b. Concentrated load of 200 pounds applied at any point and in any direction.
 - c. Uniform load of 50 pounds per linear ft. applied horizontally and simultaneous uniform load of 100 pounds per foot applied vertically downward.
 - d. Concentrated and uniform loads above shall not be applied simultaneously.
 - e. The in-fill area of freestanding sign systems shall be capable of withstanding a horizontal concentrated load of 200 pounds force applied to one sq. ft. at any point in the system including panels, intermediate, framing or other elements composing the infill area. Above load shall not be applied simultaneously with uniform horizontal loads on top frame member in determining stress on the framing.
 - f. Both framing systems and in-fill areas: completed and installed assemblies shall withstand locally mandated wind loads as permitting or code requirements stipulate.
3. **Metal Surfaces, General:** For metal fabrications exposed to view upon completion of the work, provide materials selected for their surface materials whose exposed surfaces exhibit pitting, seam marks, roller marks, rolled trade names, roughness, and, for steel sheet, variations in flatness exceeding those permitted by reference standards for stretcher-leveled sheet.
4. **Steel Plates, Shapes, and Bars:** ASTM A 36
5. **Steel Tubing:** Product type (manufacturing method) and as follows:
 - a. **Cold-Formed Rectangular Steel Tubing:** ASTM A 500, grade as indicated below:
 - b. Grade B, unless otherwise indicated or required, for design loading.
 - c. For exterior installations and where indicated, provide tubing with hot-dip galvanized coating.
6. **Uncoated Structural Steel Sheet:** Product type (manufacturing method), quality, and grade, as follows:
 - a. **Cold-Rolled Structural Steel Sheet:** ASTM A 611, grade as follows:
 - b. Grade A, unless otherwise indicated or required by design loading.
 - c. **Hot-Rolled Structural Steel Sheet:** ASTM A 570, grade as follows:
 - d. Grade 30, unless otherwise indicated or required by design loading.
7. **Uncoated Steel Sheet:** Commercial quality, product type (method of manufacture) as follows:
 - a. **Cold-Rolled Steel Sheet:** ASTM A 366.
 - b. **Hot-Rolled Steel Sheet:** ASTM A 569.
8. **Galvanized Steel Sheet:** Quality as follows:
 - a. **Structural Quality:** ASTM A 446; Grade A, unless another grade required for design loading, and G90 coating designation unless otherwise indicated.
 - b. **Commercial Quality:** ASTM A 526, G90 coating designation unless otherwise indicated.
9. **Steel Pipe:** ASTM A 53,; finish, type, and weight class as follows:
 - a. Black finish, unless otherwise indicated.
 - b. Type E or S, Grade, standard with (schedule 40), unless otherwise indicated, or another weight required by structural loads.
 - c. Roads for railings ASTM A36.
10. **Brackets, Flanges and Anchors:** Cast or formed metal of the same type material and finish as supported rails, unless otherwise indicated.
11. **Concrete Inserts:** Threaded or wedge type; galvanized ferrous castings, either malleable iron, ASTM A 47, or cast steel, ASTM A 27. Provide bolts, washers, and shims as required, hot-dip galvanized per ASTM A 153.
12. **Welding Rods and Bare Electrodes:** Select in accordance with AWS specifications for the metal alloy to be welded.

2.03 PLASTICS

- A. **Acrylic Sheet:** Acrylic, where specified, shall be as manufactured by 3Form produce Varia, or approved equal. Where required, acrylic shall be of a self-extinguishing type, which conforms to applicable building codes. Acrylic shall be of the thickness and finish indicated in the Contract Drawings.
- B. **Expanded PVC:** Expanded PVC (Polyvinylchloride), where specified, shall be of the trade name "Sintra" or approved equal. The thickness of the material shall be as indicated in the Contract Drawings.
- C. **Polycarbonate:** Polycarbonate, where specified, shall be as manufactured by General Electric under the trade name "Lexan" or approved equal. Polycarbonate shall be of the thickness and finish indicated in the Contract Drawings.

2.04 VINYL FILM

- A. All vinyl films utilized in this project shall be 3M Brand "Scotchcal", "Scotchlite Reflective", Avery Graphics brand vinyl film, or an approved equal, unless otherwise noted or specified.
- B. Application of all vinyl films shall be per manufacturer's specifications.
- C. All specified "Scotchprint" (graphics / images digitally transferred to vinyl film) shall be produced by 3M Corporation approved suppliers of Scotchprint materials and processes.

2.05 PAINT

- A. All metal coatings that may require paint shall be Catalyst Hardened Urethane (Automotive Paint) as manufactured by Matthews Paint Company of Pleasant Prairie, WI (or approved equal) Call 1-800-323- 6593 (customer service) for information. All work to be done in strict compliance with manufacture's published information and recommendations.
- B. Proposed alternates shall be equal in color and gloss retention to corresponding colors of Matthews Acrylic Polyurethane
- C. Proposed alternates shall meet or exceed the following laboratory test results from The United States Testing Company, Inc. -Hoboken, New Jersey:
 1. Testing shall consist of 1000 hours of QUV accelerated weather testing maintained in accordance with ASTM G-53.
 2. Tester shall be programmed to alternate 40 degrees Celsius water condensation 4 hour periods with 60 degree Celsius ultraviolet 4 hour periods.
 3. Gloss measurements are to be made with a Photovolt meter and color measurements with a Hunterlab color difference meter (ASTM D-523 and ASTM D-2244, respectively).
- D. The dried film surface shall conform to ANSI Z66-1 with regards to heavy metals and the surfaces shall be prepared, primed and finish coated in accordance with the coating manufacturer's instructions.

2.06 SILKSCREEN INK

- A. All inks or paints used in this project shall be specifically made for the surface on which they are to be applied, and shall be applied as recommended by the manufacturer of the ink.

- B. Prime coats and protective finish coats shall be applied as required and recommended by the ink manufacturer.
- C. Inks and finishes shall be warranted not to fade or discolor for a period of 5 years.
- D. Silk-screened graphics surface coatings shall be even and opaque without uneven or serrated edges.
- E. All silk-screen inks shall be Nazdar Corporation or approved equal.

2.07 PHOTOPOLYMER

- A. All photo-mechanically etched signage sign panels shall be etched to a consistent depth of 1/32" as required by ADA specifications for tactile graphics and Grade II Braille.
- B. All photo-mechanically etched signage shall utilize JetUSA Corporation Phenolic Series Polymer, or approved equal.
- C. Processing / manufacturing of all photo-mechanically etched polymer shall be per manufacturers specifications.
- D. Exterior Grade Phenolic Polymers shall utilize JetUSA Corporation Exterior Grade Phenolic Polymers or an approved equal.

2.08 FASTENERS & HARDWARE

- A. All fasteners used in the production or installation of this project shall be non corrosive, and be installed in a manner that will not create potentially corrosive imperfections in other materials/environments.
- B. All fasteners to be utilized in the manufacturing and installation of this project shall be identified on the shop drawings and samples submitted to the Architect for final review and approval.

2.09 SIGNAGE COLOR

- A. Signage color: Use Pantone (PMS) versions of the logo for print.
- B. The primary color usage: The primary ATL logo colors are ATL Phoenix and ATL Twilight. Pantone colors (PMS) are for PRINT ONLY and should never be used in web or digital placements. RGB and HEX are the only appropriate color formats for digital use. When the 2-color ATL logo is used, the letters "ATL" or the words "Atlanta-Region Transit Link Authority" should appear in ATL Twilight. To maintain the integrity of the brand, the ATL logo should be used appropriately and in strict accordance with the usage specifications outlined in the ATL brand style guide.
 1. ATL TWILIGHT - PANTONE 293C, C100 M70 Y0 K14, R0 G79 B150, HEX #004f97
 2. ATL PHOENIX – PANTONE 1787C, C0 M90 Y70 K0, R238 G64 B74, HEX #ee404a

- C. Left Panel of the CMS sign. The logo orientation and color shall be Horizontal 2. 2-color: PANTONE 293C, PANTONE 1787C. Applied ATL logo and center (art file to be provided from owner).



- D. Right Panel of the CMS sign. ATL full name: Atlanta-Region Transit Link Authority (art file to be provided from owner). 1-color: PANTONE 293C, Applied Text to be center on panel.

ATLANTA-REGION
TRANSIT LINK
AUTHORITY

PART 3 - EXECUTION

3.01 GENERAL

- A. Written dimensions shall take precedence over scaled dimensions on all drawings.
- B. If a disagreement is found between the written specifications and/or message schedule and those found on the specification drawings, or within the written specifications themselves, the Sign Contractor shall submit a written notice of the discrepancy to the Designer for clarification. If the discrepancy will affect the bid submittal the written notification shall be submitted at least five days prior to the bid due date so that a clarification notice may be prepared and submitted to all bidders. If the disagreement is discovered at a time such that formal clarification cannot be forwarded to all bidders, then the bidder shall submit the bid based on the written specifications. Written specifications shall take precedence over notes found on the drawings.
- C. The Sign Contractor shall be responsible for the engineering of all signage construction details and signage installation details for the signage being produced as part of this contract. The seal and signature of an engineer registered in the State of Georgia shall be included on all shop drawings along with all calculations related to the approval of engineered details. Neither the Owner, or the Designer shall be held liable for any liability resulting from negligence on the part of the Sign Contractor and/or the Sign Contractor's Engineering Consultant for damage or bodily harm related to signage construction details or installation details.

3.02 CONSTRUCTION AND FABRICATION WORKMANSHIP

- A. Aluminum Fabrication:
1. All sign faces are to be smooth and even, free from imperfections and disfiguring caused process such as welding, fasteners, ungrounded welds, "oil-canning", puckering or any other conditions not specifically mentioned herein, prior to application of paint, vinyl, ink, etc.
 2. All finish work, unless specified on the drawings, shall be smooth, free from abrasion, tool marks, visible welds, exposed fasteners or similar defects prior to application of paint, vinyl, ink, etc.
 3. All corners, reveals, and joints shall be milled to match adjoining pieces and shall be fabricated so as to match the dimensions indicated in the Sign Specification Drawings.

4. No brake bending or forming of the exterior corners of the sign units shall be acceptable unless otherwise noted in the Sign Specification Drawings. All aluminum parts shall be saw cut. All external welds shall be continuous, filled and ground smooth so that the finished seams are not visible in the finished product.
5. Internal welds shall be structurally sound and eliminate racking.
6. There shall be no bare aluminum in contact with any other metals, woods or concrete. Contact surfaces shall be separated by a heavy body bituminous paint or by a gasket.
7. Seams which must occur in a sign face, shall be filled and finished smooth prior to priming and painting of the finished sign unit. Seams shall not be visible in the finished product and shall be constructed in a manner that will insure that the finished seam will not "crack" or "protrude" over time.

B. Typography & Graphics:

1. The Sign Contractor is responsible for providing or obtaining all symbol artwork used in this project and illustrated in the Symbol Specifications or Specification Drawings. All symbols, to be used in this project must be shown in the submitted shop drawings for approval prior to production.
2. Typefaces and symbols for this project are illustrated in the Typography & Symbol Specifications of this document. The Sign Contractor is responsible for using the exact typefaces and symbols illustrated in the Sign Specification Drawings. If the Sign Contractor is unsure of a typeface's identity or a symbol's details, the Sign Contractor shall consult with the Designer.
3. Silk Screened Graphics
 - a. All photo silk screened graphics shall be sharp, without irregular or serrated edges, and exactly true to letter style or design form.
 - b. All ink applications shall be applied per the manufacturers recommended specifications for the surface on which the ink shall be applied.
 - c. Ink shall not be applied until the preceding coat has dried.
 - d. Application of ink shall be even and consistent without variation in the color. The ink application shall be opaque to avoid "shadowing" from background colors.
 - e. All Silk-screen inks used shall be those specified by the manufacturer for interior or exterior use.
4. Applied Screened Graphics
 - a. All vinyl typography, symbols and graphics shall be precision machine cut utilizing current computer capabilities. Only in exceptional cases is hand cutting of vinyl graphics permitted and must be disclosed at time of bid submittal.
 - b. All vinyl graphics shall be cut sharp and even without serrated edges, and exactly true to the graphics form.
 - c. Vinyl graphics shall be applied per the manufacturer's recommendations. Air bubbles or wrinkles in the finished surface will not be acceptable or approved.
 - d. In situations where the vinyl film is being applied to a painted surface, the Contractor must take precautions to insure that the painted surface has dried thoroughly to prevent damage to the vinyl caused by out-gassing of the curing paint surface.
 - e. All applied vinyl graphics shall be installed per manufacturer's specifications.
5. Dimensional Graphics
 - a. All dimensional typography and graphics shall be machine cut by computer driven laser or water jet technique.
 - b. Dimensional graphics shall be cut from the material and material thickness specified in the Sign Specification Drawings.

- c. The edges of all dimensional graphics shall be sharp, even and true to the typestyle or graphic specified. Edges shall not be "eased" or rounded in any way.
- d. Unless otherwise specified, all dimensional graphics shall be pin-mounted, and mounted flush to the substrate specified. The Contractor shall review the mounting substrate conditions at each sign location to receive dimensional graphics and adjust the mounting pins accordingly.
- e. All dimensional graphics shall be applied with an even baseline and on proper letterform axis. The face of all graphics shall be installed in the same plane.

C. Color and Finish

- 1. Refer to the Sign Specification Drawings to determine the colors/materials for each signage or graphic element. Color & Material reference numbers are designated on the Sign Specification Drawings. Refer to the Color Schedule for color designations.
- 2. Coatings and finishes are to accurately match the colors specified by the Designer and color samples approved per the color submittal process.
- 3. All coating applications shall be smooth, even and consistently uniform. The cured surface shall have a uniform finish that matches the specified color and finish.
- 4. Color breaks that occur on the visible portions of the signage or graphics shall be sharp and even without serration or color bleed.
- 5. All splatters, drips, spills or over sprays shall be removed or corrected prior to final inspection by the Designer.
- 6. Exact identification of all coatings and finishes shall be identified in the Shop Drawing submittal and shall indicate the method of application.
- 7. All finished coatings and finishes shall receive a protective clear coat to aid in the durability of the finish as well as aid in the ease of cleaning.
- 8. All colors and finishes shall be applied per the manufacturer's specifications or recommendations for the material to receive the coating.

3.03 PRODUCT INSPECTION

- A. Prior to shipment to site for installation, all finished and completed graphics and signage shall be inspected in the contractor's shop by the Designer. All signage shall be completed, labeled and displayed in a manner that will provide for an expeditious review by the Designer.

3.04 LABELING, STORAGE, DELIVERY

- A. All products shall be stored in protective packaging to prevent damage. Any completed product must be stored in a bonded storage facility until installation.
- B. All sign products shall be packaged for protection from damage during shipment to the project site. All products shall be clearly labeled for easy identification while in the protective packaging. Identification shall include sign type number and sign location number per the contract drawings and plans.
- C. The Contractor is responsible for any damage which occurs during the shipment of graphics and signage related products to the project site.

3.05 INSPECTION OF SITE

- A. Surfaces to receive graphics and signage shall be free from defects and imperfections that would prevent an acceptable installation.
- B. Commencement of work in any space shall constitute acceptance by the Contractor of surfaces to receive signage as being in a satisfactory condition to permit an acceptable installation. If the Contractor's inspection of the application surfaces discloses unsatisfactory conditions, he shall notify the Designer in writing and await further instruction; otherwise, no claims will be considered for unsatisfactory work due to real or alleged faulty surfaces.

3.06 INSTALLATION, ERECTION, APPLICATION

- A. If the Sign Contractor does not feel it will be possible to meet the final completion date due to the delay by the Owner's review of shop drawings, a written report must be submitted to The Owner and the Owner/Owner's Construction Manager outlining the specific areas of concern. This report must be filed at least two weeks prior to the installation deadline in order to avoid penalties being levied against the Sign Contractor.
- B. Signage locations: Prior to installation, the Sign Contractor and an Owner representative shall conduct a final walk through to stake out all sign locations.
- C. The Contractor is responsible for providing all materials and equipment necessary to properly locate and document the exact sign placement and orientation in the field.
 - 1. Marking materials shall not disfigure or permanently mar the installation environment and must be removed immediately following signage installation.
 - 2. Sign markers shall indicate the Sign Location Number, Sign Type Number, and Sign Face if applicable.
- D. If the Sign Contractor elects to sub-contract graphics/signage installation, the Sign Contractor must have a Project Manager on-site at all times during the installation process.
- E. The Sign Contractor shall at all times guard from damage or loss, the areas around each sign, and shall replace or repair any loss or damage. The Owner may withhold payment or make such deductions as deemed necessary to insure reimbursement for loss or damage to property through negligence of the Sign Contractor or his agents. The Sign Contractor shall at all times guard against injury to persons within the sign facility site and the sign site.
- F. During the installation phase of the project, the Sign Contractor shall structure the work and provide adequate and qualified personnel to insure the least amount of inconvenience and interruption of normal daily activities of adjacent property owners/residents. Working hours shall have the approval of the Owner.
- G. All debris relating to signage installation must be removed from the areas of the project after completion of the installation phase.
- H. The Owner or an Owner Representative will conduct a post installation inspection of the sign units only after all signage and graphics are installed. To prevent damage to the sign units between installation and final review the Sign Contractor must take precautions to protect the individual sign units. In addition, the Sign Contractor must provide The Owner with a detailed installation schedule and completion time so that the final review may be conducted in a timely manner. Liability for sign units damaged between installation and final review shall be resolved between the Sign Contractor and the subcontractor for the sign if a subcontractor is used. Otherwise, all cost shall be borne by the Sign Contractor.
- I. Timing of Signage Installation / Hours of Installation shall be at the direction of the Owner.

3.03 PROTECTION

- A. Work in progress shall be protected at all times from staining, scratching, chipping or other damage.
- B. Provide final protection in a manner acceptable to the fabricator and installer until Date of Substantial Completion.
- C. Acrylic shall be removed from protective wrapping only as required to facilitate installation. Care shall be taken in handling acrylic sheets to prevent scratching, chipping or crazing.

3.04 CLEANING AND ADJUSTMENTS

- A. Clean exposed surfaces promptly after completion of installation in accordance with manufacturer's written cleaning instructions.
- B. Remove and replace damaged signage and graphics with new graphics free of defects.
- C. Clean exposed metal work with cleanser recommended by the manufacturer. Do not use harsh chemicals or abrasive matter in cleaning signage. Surfaces with stains or imperfections, which cannot be corrected or cleaned, shall be replaced to the satisfaction of the Owner without additional cost to the Owner.
- D. Signs shall be free of tape, packing paper, dirt smudges and other foreign materials.
- E. All installed signage and graphics shall be left level and fully cleaned on the Date of Substantial completion by the Contractor.

3.05 EXTRA PARTS

- A. Loose parts of sign assemblies, and/or special tools shall be itemized and supplied to the Owner upon completion of the project.

3.06 PAYMENT

- A. Payment for the entry monument sign shall be lump sum and shall include all items such as concrete footing, sign panels, metal and aluminum panels, finishes, lettering, graphics, LED lighting, logos, and CMS sign conduit installation. The payment is full compensation for all excavation, furnishing and installation of entry monument sign, materials, disposal of materials, cost of furnishing all tools, safety devices, labor, equipment, and all other necessary items to complete the work.

END OF SECTION

State Road and Tollway Authority (SRTA), State of Georgia

SPECIAL PROVISION

Section 700 – Grassing (Seeding and Sodding)

700.1 General Description

This work includes preparing the ground, furnishing, planting, seeding, hydroseeding, fertilizing, sodding, and mulching disturbed areas within the project limits as shown on the Plans.

700.1.1 Definitions

General Provisions 101 through 150.

700.1.2 Related References

A. Standard Specifications

Section 160—Reclamation of Material Pits and Waste Areas

Section 163—Miscellaneous Erosion Control Items

Special Provision Section 708 – Plant Topsoil

Section 718—Wood Fiber

Section 822—Emulsified Asphalt

Section 882—Lime

Section 890—Seed and Sod

Section 891 Fertilizers

Section 893—Miscellaneous Planting Materials

Section 895—Polyacrylamide

B. Referenced Documents

QPL 33

QPL 84

700.1.3 Submittals

Submit manufacturer's product expiration date along with written instructions to ensure proper application, safety, storage, and handling of Polyacrylamide products used in The Work.

Product Data: For each type of product indicated in the landscape plans.

Certification of Grass Seed: From seed vendor for each grass-seed monostand or mixture stating the botanical and common name and percentage by weight of each species and variety, and percentage of purity, germination, and weed seed. Include the year of production and date of packaging.

Product Certificates: For existing surface soil and imported topsoil.

1. Results of analysis of topsoil indicating required nutrient and lime application rates.

Quality Assurance

Installer's Qualifications: A qualified landscape installer whose work has resulted in successful law / sod and native grass and wildflower seed mix establishment. Installer field supervision is required to maintain an experienced staff when planting.

700.2 Materials

Use materials that meet the requirements of the following Specifications:

Material	Section
Wood Fiber Mulch	718.2
Agricultural Lime	882.2.01
Seed	890.2.01
Sod	890.2.02
Fertilizer	891.2.01
Plant Topsoil	893.2.01
Mulch	893.2.02
Inoculants	893.2.04
Tackifiers	QPL 33
Anionic Polyacrylamide	QPL 84 & Section 895

A. Seeds

Whenever seeds are specified by their common names, use the strains indicated by their botanical names.

B. Water

Obtain the water for grassing from an approved source. Use water free of harmful chemicals, acids, alkalis, and other substances that may harm plant growth or emit odors. Do not use salt or brackish water.

C. Agricultural Lime

Agricultural lime rates will be based on a laboratory soil test report. The Contractor is responsible for ensuring the tests are performed by an approved laboratory. Provide a copy of test results to the Engineer. Refer to Section 882 Lime and GSP 18 of the Sampling and Testing Inspection manual for additional information on rates, use, handling and sampling procedures.

D. Fertilizer Mixed Grade

Fertilizer analysis and rates will be based on a laboratory soil test report. The Contractor is responsible for ensuring the tests are performed by an approved laboratory. Provide a copy of test results to the Engineer. Refer to Section 891 Fertilizer and GSP 18 of the Sampling and Testing Inspection manual for additional information on rates, use, handling and sampling procedures.

E. Mulch

Use straw or hay mulch according to [Subsection 700.3.05.G.](#)

Use wood fiber mulch in hydroseeding according to [Subsection 700.3.05.F.1.](#)

700.2.01 Delivery, Storage, and Handling

General Provisions 101 through 150.

700.3 Construction Requirements**700.3.1 Personnel**

General Provisions 101 through 150.

700.3.2 Equipment

Use grassing equipment able to produce the required results.

Never allow the grading (height of cut) to exceed the grassing equipment's operating range.

A. Mulch Material Equipment

Use mulching equipment that uniformly cuts the specified materials into the soil to the required control depth.

B. Hydroseeding Equipment

For hydroseeding equipment, see [Subsection 700.3.05.F](#).

700.3.3 Preparation

General Provisions 101 through 150.

700.3.4 Fabrication

General Provisions 101 through 150.

700.3.5 Construction

Follow the planting zones, planting dates, types of seed, seed mixtures, and application rates described throughout this Section. The Engineer has the authority to alter the planting dates as set forth by a period of 2 weeks. This 2-week period may be applied to either the beginning of the specified planting and/or to the end of the end of the specified planting season.

In general:

- Obtain the Engineer's approval before changing the groundcover type.
- Do not use annual rye grass seeds with permanent grassing.
- Follow the planting zones indicated on the [Georgia State Planting Zone Map, below](#).
- Sod may only be installed when not dormant, weather permitting.
- For permanent grassing, apply the combined amounts of all seeds for each time period within each planting zone and roadway location listed in the [Seeding Table, below](#). Do not exceed the amounts of specified seed.

PLANTING ZONE MAP

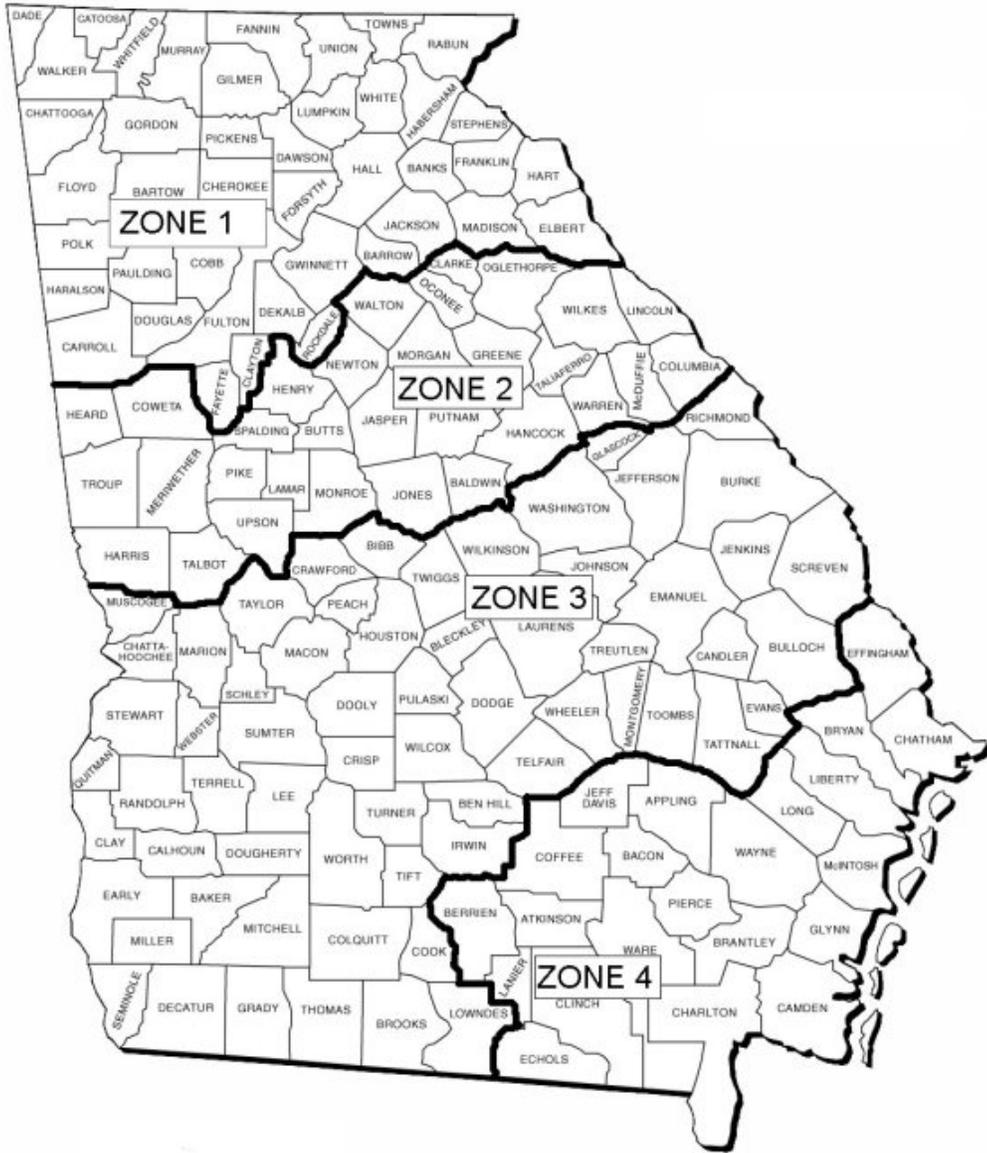

NON-NATIVE GRASS SEEDING TABLE 1
(Temporary and Permanent Seed Types for Shoulders, Medians and Slopes 3:1 or Flatter)

USE ONLY IF DIRECTED BY ENGINEER / LANDSCAPE ARCHITECT

Common Name	Botanical Name	Class/Type	Rate /Acr	Planting Zone	Planting Dates
Common Bermuda Grass (Hulled)	<i>Cynodon dactylon</i>	Required Permanent Grass	10 (11)	1	April 16 – August 31
Common Bermuda Grass (Un-hulled)			10 (11)		
Common Bermuda Grass (Hulled)	<i>Cynodon dactylon</i>	Required Permanent Grass	10 (11)	2,3,4	April 1 – October 15
Common Bermuda Grass (Un-hulled)			10 (11)		
Bahaia Grass	<i>Paspalum motatum</i>		10 (11)		
Rye Grass, Millet, Cereal Grass (Oats)	<i>Lolium penne ssp. Multiflorum, Echinochloa cursgalli, Avena sativa</i>	Temporary Grass	50 (56)	1	September 1- April 15
Rye Grass, Millet, Cereal Grass (Oats)	<i>Lolium penne ssp. Multiflorum, Echinochloa cursgalli, Avena sativa</i>	Temporary Grass	50 (56)	2,3,4	October 16- March 31

NON-NATIVE SEEDING TABLE 2
(Temporary and Permanent Seed Types
for back slopes, fill slopes and areas which will not be
subject to frequent mowing, slopes steeper than 3:1)

USE ONLY IF DIRECTED BY ENGINEER / LANDSCAPE ARCHITECT

Common Name	Botanical Name	Class/Type	Rate/Acre	Planting Zone	Planting Dates
Interstate Lespedeza	<i>Lespedeza sericea</i>	Permanent Grass	50(56)	1,2	March 1 – August 31
Weeping Lovegrass	<i>Eragrostis curvula</i>	Temporary Grass	10(11)		
Interstate Lespedeza	<i>Lespedeza sericea</i>	Permanent Grass	75(84)	1,2	September 1- February 28
Tall Fescue	<i>Festuca arundinacea</i>	Temporary Grass	50(56)		
Interstate Lespedeza	<i>Lespedeza sericea</i>	Permanent Grass	50(56)	3,4	April 1 – October 31
Weeping Love Grass	<i>Eragrostis curvula</i>	Temporary Grass	10(11)		
Interstate Lespedeza	<i>Lespedeza sericea</i>	Permanent Grass	50(56)	3,4	November 1 – March 31
Weeping Love Grass	<i>Eragrostis curvula</i>	Temporary Grass	10(11)		

NATIVE GRASS SEEDING TABLE 3**For Non-mowable Slopes or Areas Designated as Permanent Native Grass Seed Mix.**

Plant native seed mixes on back slopes, fill slopes and areas which will not be subject to frequent mowing (slopes steeper than 3:1) or as shown on the landscape plans.

Common Name	Botanical Name	Rate/Acre	% Germination	Planting Dates
Broomsedge	<i>Andropogon virginicus</i>	See Plant Schedule	100% Pure Seed	Per Manufacturer
Virginia Wild Rye	<i>Elymus virginicus</i>	See Plant Schedule	100% Pure Seed	Per Manufacturer
Little Bluestem	<i>Schizachyrium scoparium</i>	See Plant Schedule	100% Pure Seed	Per Manufacturer
Purple Top	<i>Tridens flavus</i>	See Plant Schedule	100% Pure Seed	Per Manufacturer

See plan sheets/plant lists for detailed native grass seed mix locations. Apply at rate as shown on the plant schedule.

**DBWT DETENTION BASIN NATIVE
GRASS SEED MIX TABLE 4**

For Non-mowable Slopes or Areas Designated as Permanent Detention Basin Native Grass Seed Mix.

Plant detention basin native seed mixes on as shown on the landscape plans.

Common name	Botanical name	Rate/ Acre	% Germination	Planting Dates
Water Plantain	<i>Alisma subcordatum</i>	See Plant Schedule	Per Manufacturer	Per Manufacturer
Swamp milk-weed	<i>Asclepias incarnata</i>	See Plant Schedule	Per Manufacturer	Per Manufacturer
Tickseed Sun-flower	<i>Bidens aristosa</i>	See Plant Schedule	Per Manufacturer	Per Manufacturer
Awl-Fruited Sedge	<i>Carex stipata</i>	See Plant Schedule	Per Manufacturer	Per Manufacturer
Fox Sedge	<i>Carex vulpinoidea</i>	See Plant Schedule	Per Manufacturer	Per Manufacturer
Virginia Wildrye	<i>Elymus virginicus</i>	See Plant Schedule	Per Manufacturer	Per Manufacturer
Spike Rush	<i>Eleocharis species</i>	See Plant Schedule	Per Manufacturer	Per Manufacturer
Fowl Manna Grass	<i>Glyceria striata</i>	See Plant Schedule	Per Manufacturer	Per Manufacturer
Soft Rush	<i>Juncus effusus</i>	See Plant Schedule	Per Manufacturer	Per Manufacturer
Path Rush	<i>Juncus tenuis</i>	See Plant Schedule	Per Manufacturer	Per Manufacturer
Rice Cut Grass	<i>Leersia oryzoides</i>	See Plant Schedule	Per Manufacturer	Per Manufacturer
Allegheny Monkeyflower	<i>Mimulus ringens</i>	See Plant Schedule	Per Manufacturer	Per Manufacturer
Switchgrass	<i>Panicum virgatum</i>	See Plant Schedule	Per Manufacturer	Per Manufacturer
Ditch Stonecrop	<i>Penthorum sedoides</i>	See Plant Schedule	Per Manufacturer	Per Manufacturer
Softstem Bulrush	<i>Scirpus validus</i>	See Plant Schedule	Per Manufacturer	Per Manufacturer
Prairie Cordgrass	<i>Spartina pectinata</i>	See Plant Schedule	Per Manufacturer	Per Manufacturer
Cutleaf Cone-flower	<i>Rudbeckia laciniata</i>	See Plant Schedule	Per Manufacturer	Per Manufacturer
Blue Vervain	<i>Verbena hastata</i>	See Plant Schedule	Per Manufacturer	Per Manufacturer

For detention basin native grass seed mix, use Table 4 for approved seed types. This mix is composed of tenacious species of wildflowers, grasses, rushes and sedges that can tolerate areas that are inundated periodically by water.

TABLE 5: TEMPORARY GRASS - SPECIES, SEEDING RATES AND PLANTING DATES

Species	Rates per 1000 sq. ft.	Rates per Acre	Planting Date By Zone		
			1 & 2	2	3 & 4
Rye (Grain)	3.9 lbs	168 lbs	8/1 - 11/30	8/15 - 12/1	9/1 - 2/28
Ryegrass	0.9 lbs	40 lbs	8/1 - 11/30	9/1 - 12/15	9/15 - 1/1
Rye & Annual Lespedeza	0.6 lbs 0.6 lbs	28 lbs 24 lbs	3/1 - 4/1	2/1 - 3/1	2/1 - 3/1
Weeping Lovegrass	0.1 lbs	4 lbs	3/15 - 6/15	3/15 - 7/15	3/15 - 7/15
Sudangrass	1.0 lbs	60 lbs	4/1 - 8/31	4/1 - 8/31	3/15 - 8/1
Browntop Millet	1.1 lbs	50 lbs	4/1 - 6/30	4/1 - 7/15	4/1 - 7/15
Wheat	3.9 lbs	168 lbs	9/1 - 12/31	9/1 - 12/31	9/15 - 1/31

When stage construction or other conditions prevent completing a roadway section continuously, apply temporary grassing to control erosion. Temporary grassing is used to stabilize disturbed areas for more than sixty (60) calendar days. Temporary grass may be applied any time of the year, utilizing the appropriate seed species and application rate as shown in the chart above. Apply mulch to areas planted in temporary grass at the rate of ¼ inch to 1.5 inches. Do not place slope mats on areas planted in temporary grass.

A. Ground Preparation

Prepare the ground by plowing under any temporary grass areas and preparing the soil as follows:

1. Slopes 3:1 or Flatter

On slopes 3:1 or flatter, plow shoulders and embankment slopes to between 4 in and 6 in (100 mm and 150 mm) deep.

Plow front and back slopes in cuts to no less than 6 in (150 mm) deep. After plowing, thoroughly disk the area until pulverized to the plowed depth.

2. Slopes Steeper Than 3:1

Serrate slopes steeper than 3:1 according to Plan details when required.

On embankment slopes and cut slopes not requiring serration (sufficient as determined by the Engineer), prepare the ground to develop an adequate seed bed using any of the following methods as directed by the Engineer:

- Plow to a depth whatever depth is practicable. Use a spiked chain.
- Walk with a cleated track dozer. Scarify.
- Disking cut slopes and fill slopes is not required.

3. All Slopes

a. Obstructions

Remove boulders, stumps, large roots, large clods, and other objects that interfere with grassing or may slide into the ditch.

b. Topsoil

Spread topsoil stockpiled during grading evenly over cut and fill slopes after preparing the ground.

Push topsoil from the top over serrated slopes. Do not operate equipment on the face of completed serrated cuts.

4. **Native Restoration Areas, Riparian Areas, Stream Restoration Areas, and Wetland and Stream Mitigation Areas.**

For Permanent Grassing in native restoration areas, multitrophic native planting areas, riparian areas, stream restoration areas, and wetland and stream mitigation areas, provide the minimum ground preparation necessary to provide seed to soil contact. Riparian areas may also be seeded using the no-till method. The no-till method is defined by planting permanent grass seeds using a drill-type seeder over existing vegetation without plowing or tilling soil. Ensure that existing vegetation is less than 3 inches in height (this may be achieved by mowing or using a mechanical string trimmer).

B. Grassing Adjacent to Existing Lawns

When grassing areas adjacent to residential or commercial lawns, the Engineer shall change the plant material to match the type of grass growing on the adjacent lawn. The Contract Unit Price will not be modified for this substitution.

C. Temporary Grassing

Apply temporary grassing according to [Subsection 163.3.05.F](#). Determine lime requirements by a laboratory soil test. Refer to seeding Table 5 for species, amounts of seed and planting dates.

In March or April of the year following planting and as soon as the weather is suitable, replace all areas of temporary grass with permanent grass by plowing or overseeding using the no-till method. If the no-till method is used, ensure that temporary grass is less than 3 inches in height (this may be achieved by mowing). Additional mulch will be required only if the temporary grass does not provide adequate mulch to meet the requirements of [Subsection 700.3.05.G, "Mulching"](#).

Temporary grass, when required, will be paid for according to [Section 163](#).

Projects that consist of asphalt resurfacing with shoulder reconstruction and/or shoulder widening: Type II Wood Fiber Blanket is used to stabilize disturbed areas, no till seeding will be used when permanent grassing is applied and the areas will not be re-disturbed.

D. Applying Agricultural Lime and Fertilizer Mixed Grade

Apply and mix lime and fertilizer as follows:

1. **Agricultural Lime**

Uniformly spread agricultural lime on the ground at the approximate rate determined by the laboratory soil test.

- a. Agricultural Lime may be used as filler material in mixed grade fertilizer in lieu of inert material. The use of agricultural lime as filler material is to be shown on the fertilizer bag or invoice from the supplier. Do not deduct any amount of fertilizer when lime is used as filler.

2. **Fertilizer Mixed Grade**

Uniformly spread the fertilizer selected according to [Subsection 700.2.D](#) over the ground or by use of hydroseeding. For bid purposes base estimated quantities on an initial application of 400 lb/acre of 19-19-19.

3. **Mixing**

Before proceeding, uniformly work the lime and fertilizer into the top 4 in (100 mm) of soil using harrows, rotary tillers, or other equipment acceptable to the Engineer.

On cut slopes steeper than 3:1, other than serrated slopes, reduce the mixing depth to the max-

imum practical depth as determined by the Engineer.

Omit mixing on serrated slopes.

4. Native Restoration Areas, Multitropic Native Planting Areas, Riparian Areas, Stream Restoration Areas, and Wetland and Stream Mitigation Areas

Omit the application of lime and fertilizer within riparian areas.

E. Seeding

Prepare seed and sow as follows:

1. Inoculation of Seed

Inoculate each kind of leguminous seed separately with the appropriate commercial culture according to the manufacturer's instructions for the culture.

When hydroseeding, double the inoculation rate.

Protect inoculated seed from the sun and plant it the same day it is inoculated.

2. Sowing

Weather permitting, sow seed within 24 hours after preparing the seed bed and applying the fertilizer and lime.

Sow seed uniformly at the rates specified in the seeding tables. Use approved mechanical seed drills, rotary hand seeders, hydroseeding equipment, or other equipment to uniformly apply the seed. Do not distribute by hand.

To distribute the seeds evenly sow seed types separately, except for similarly sized and weighted seeds. They may be mixed and sown together.

Do not sow during windy weather, when the prepared surface is crusted, or when the ground is frozen, wet, or otherwise non-tillable.

3. Overseeding

Temporary grass areas that were prepared in accordance with [Subsection 700.3.05.A](#), may be overseeded using the no-till method. The no-till method is defined by planting permanent grass seeds using a drill-type seeder over existing temporary grass without plowing or tilling soil and in accordance with [Subsection 700.3.05.C](#).

4. Riparian Seed Mix shall be used when specified in the Plans. A mix of at least three (3) species from Seeding Table 3 (Native Grasses) and at least two (2) species from Seeding Table 4 (Approved Riparian Mitigation - Herbaceous Plants). The seed, shall be applied as Permanent Grassing within those areas designated on the Plans. The kinds of seed, shall be used according to the appropriate Planting Dates given in the tables.

F. Hydroseeding

Hydroseeding may be used on any grassing area. Under this method, spread the seed, fertilizer, and wood fiber mulch in the form of a slurry. Seeds of all sizes may be mixed together. Apply hydroseeding as follows:

1. Use wood fiber mulch as a metering agent and seed bed regardless of which mulching method is chosen. Apply wood fiber mulch at approximately 500 lbs/acre (560 kg/ha).
2. Prepare the ground for hydroseeding as for conventional seeding in [Subsection 700.3.05.A](#).
3. Use specially designed equipment to mix and apply the slurry uniformly over the entire seeding area.
4. Agitate the slurry mixture during application.
5. Discharge slurry within one hour after being combined in the hydroseeder. Do not hydroseed when winds prevent an even application.
6. Closely follow the equipment manufacturer's directions unless the Engineer modifies the application methods.
7. Mulch the entire hydroseeded area according to [Subsection 700.3.05.F.1](#), above, and [Subsec-](#)

[tion 700.3.05.G](#), below.

Native Restoration Areas, Multitropic Native Planting Areas, Riparian Areas, Stream Restoration Areas, and Wetland and Stream Mitigation Areas may be hydroseeded. When hydroseeding in these areas only use water, seed and wood fiber mulch.

G. Mulching

Except as noted in [Subsection 700.3.05.B](#) and [Subsection 700.3.05.C](#), apply mulch immediately after seeding areas as follows:

Areas with permanent grass seed and covered with slope mats or blankets will not require mulch.

Evenly apply straw or hay mulch between 3/4 in and 1-1/2 in (20 mm and 40 mm) deep, according to the texture and moisture content of the mulch material.

Mulch shall allow sunlight to penetrate and air to circulate as well as shade the ground, reduce erosion, and conserve soil moisture. If the type of mulch is not specified on the Plans or in the Proposal, use any of the following as specified.

1. Mulch with Tackifier

Apply mulch with tackifier regardless of whether using ground or hydroseeding equipment for seeding.

- a. Mulch uniformly applied manually or with special blower equipment designed for the purpose. When using a blower, thoroughly loosen baled material before feeding it into the machine so that it is broken up.
- b. After distributing the mulch initially, redistribute it to bare or inadequately covered areas in clumps dense enough to prevent new grass from emerging (if required).
Do not apply mulch on windy days.

- e. Apply enough tackifier to the mulch to hold it in place. Immediately replace mulch that blows away. If distributing the mulch by hand, immediately apply the
 - tackifier uniformly over the mulched areas.

Tackifier: Use a tackifier listed in the Laboratory Qualified Products Manual and apply at the manufacturer's recommended rates.

2. Walked-in-Mulch

Apply walked-in-mulch on slopes ranging in steepness from 5:1 to 2:1 and treat as follows:

- a. Immediately walk it into the soil with a cleated track dozer. Make dozer passes vertically up and down the slope.
- b. Where walked-in-mulch is used, do not roll or cover the seeds as specified in [Subsection 700.3.05.E.3](#).

3. Apply only wheat straw mulch on Riparian Areas, Stream Restoration Areas, and Wetland and Stream Mitigation Areas after they have been seeded. The wheat straw mulch is to be applied with a maximum thickness of 1 inch.

H. Sod

Furnish and install sod in all areas shown on the Plans or designated by the Engineer.

1. Kinds of Sod

Use only one of the following varieties:

Bermuda Tif Tuf

Geo Zoysia

Sod shall be nursery-grown and be accompanied with a Georgia Department of Agriculture Live Plant License Certificate or Stamp. Sod shall consist of live, dense, well-rooted material free of weeds and insects as described by the Georgia Live Plant Act.

2. Type And Size Of Sod:

Furnish either big roll or block sod. Ensure that big roll sod is a minimum of 21 inches wide by 52 feet long. Minimum dimensions for block sod are 12 inches wide by 22 inches long. Ensure all sod consists of a uniform soil thickness of not less than 1 inch.

3. Ground Preparation

Excavate the ground deep enough and prepare it according to [Subsection 700.3.05.A](#) to allow placing of sod. Spread soil, meeting the requirements of [Subsection 893.2.01](#), on prepared area to a depth of 4 inches.

4. Application of Lime and Fertilizer

Apply lime and fertilizer according to [Subsection 700.3.05.D](#) within 24 hours prior to installing sod.

5. Weather Limitation

Do not place sod on frozen ground or where snow may hinder establishment.

6. Install Sod

Install Sod as follows:

- Place sod by hand or by mechanical means so that joints are tightly abutted with no overlaps or gaps. Use soil to fill cracks between sod pieces, but do not smother the grass.
 - Stake sod placed in ditches or slopes steeper than 2:1 or any other areas where sod slipping can occur. Use wood stakes that are at least 8 in (200 mm) in length and not more than 1 in (25 mm) wide.
 - Drive the stakes flush with the top of the sod. Use a minimum of 8 stakes per square yard (meter) to hold sod in place.
- Once sod is placed and staked as necessary, tamp or roll it using adequate equipment to provide good contact with soil.
- Use caution to prevent tearing or displacement of sod during this process. Leave the finished surface of sodded areas smooth and uniform.

7. Watering Sod

After the sod has been placed and rolled or tamped, water it to promote satisfactory growth. Additional watering will be needed in the absence of rainfall and during the hot dry summer months. Water may be applied by Hydro Seeder, Water Truck or by other means approved by the Engineer.

8. Dormant Sod

Dormant sod can be installed. However, assume responsibility for all sod through establishment and until final acceptance.

9. Establishment

Sod will be inspected by the Engineer at the end of the first spring after installation and at the time of Final Inspection. Replace any sod that is not live and growing. Any cost for replacing any unacceptable sod will be at the Contractor's expense.

I. Application of Nitrogen

Apply nitrogen at approximately 50 lbs/acre (56 kg/ha) when specified by the Engineer after plants have grown to 2 inches (50 mm) in height.

One application is mandatory and must be applied before Final Acceptance.

Apply nitrogen with mechanical hand spreaders or other approved spreaders capable of uniformly covering the grassed areas. Do not apply nitrogen on windy days or when foliage is damp.

Do not apply nitrogen between October 15 and March 15 except in Zone 4.

1. Native Restoration Areas, Multitropic Native Planting Areas, Riparian Areas, Stream Restoration Areas, and Wetland and Stream Mitigation Areas

Do not apply nitrogen to these areas.

J. Application of Polyacrylamide (PAM)

1. Prepare soil according to project Plans and Specifications prior to applying PAM.
2. Apply PAM according to manufacturer's recommendations and the requirements listed herein.
3. Apply Polyacrylamide (PAM) to all areas that receive permanent grassing.
4. Apply PAM (powder) before grassing or PAM (emulsion) to the hydroseeding operation.
5. Use only anionic PAM.
6. Ensure that the application method provides uniform coverage to the target and avoids drift to non-target areas including waters of the state.
7. Achieve > 80% reduction in soil loss as measured by a rainfall simulator test performed by a certified laboratory (1 hour storm duration, 3 inches (75 mm) rainfall per hour).
8. Ensure uniform coverage to the target area and minimize drift to non-target areas. Apply anionic PAM to all cut and fill slopes, permanently grassed or temporarily grassed, either prior to grassing or in conjunction with hydroseeding operations. Mulch will not be eliminated.
9. Use application rates in accordance with manufacturer's instructions.
10. Do not exceed 200 lbs/acre/year (224 kg/ha/year).
11. Do not include polyacrylamide when planting in Riparian Areas, Stream Restoration Areas, and Wetland and Stream Mitigation Areas

700.3.6 Quality Acceptance

The Engineer may require replanting of an area that shows unsatisfactory growth for any reason at any time.

Except as otherwise specified or permitted by the Engineer, prepare replanting areas according to the Specifications as if they were the initial planting areas. Use a soil test or the Engineer's guidance to determine the fertilizer type and application rate, then furnish and apply the fertilizer.

700.3.7 Contractor Warranty and Maintenance

A. Plant Establishment

Before Final Acceptance, provide plant establishment of the specified vegetation as follows:

1. **Plant Establishment**
Preserve, protect, water, reseed or replant, and perform other work as necessary to keep the grassed areas in satisfactory condition.
2. **Watering**
Water the areas during this period as necessary to promote maximum growth.
3. **Mowing**
Mow seeded areas of medians, shoulders, and front slopes at least every 6 months. Avoid damaging desirable vegetation.
In addition, mow as necessary to prevent tall grass from obstructing signs, delineation, traffic movements, sight distance, or otherwise becoming a hazard to motorists.
Do not mow lespedezas or tall fescue until after the plants have gone to seed.
4. Do not mow riparian areas, stream restoration areas, or wetland and stream mitigation areas after planting.

B. Additional Fertilizer Mixed Grade

Apply fertilizer based on the initial soil test report at half the recommended rate each spring after initial plant establishment. For bid purposes apply 200 lbs/acre of 19-19-19. Continue annual ap-

plications until Final Acceptance. This additional fertilizer will be measured and paid for at the Contract Unit Price for fertilizer mixed grade.

Do not apply additional fertilizer to Native Restoration Areas, Multitropic Native Planting Areas, Riparian Areas, Stream Restoration Areas, and Wetland and Stream Mitigation Areas.

C. Growth and Coverage

Provide satisfactory growth and coverage, ensuring that vegetation growth is satisfactory with no bare spots larger than 1 ft² (0.1 m²). Bare spots shall comprise no more than 1 percent of any given area. An exception is given for seed not expected to have germinated and shown growth at that time.

D. Permissible Modifications

When all Items of the work are ready for Final Acceptance except for newly planted repaired areas or other areas with insufficient grass, the Contractor may fill the eroded areas or treat bare areas with sod obtained, placed, and handled according to [Subsection 700.3.05.H](#).

Carefully maintain the line and grade established for shoulders, front slopes, medians, and other critical areas.

Sod as described above will not be paid for separately, but will be an acceptable substitute for the satisfactory growth and coverage required under this Specification. These areas treated with sod are measured for payment under the Item for which the sod is substituted.

700.4 Measurement

A. Permanent Grassing (Native Seed Mixes)

Permanent Grassing will be measured for payment by the acre (hectare).

B. Mulches

Straw or hay mulch applied to permanent grassing areas will be measured by the ton (megagram). Wood fiber mulch furnished by the Contractor for permanent grassing is not measured for separate payment.

C. Quantity of Sod

Sod is measured for payment by the number of square yards (meters) , surface measure, completed and accepted.

D. Water

Water furnished and applied to promote a satisfactory growth is not measured for payment.

E. Quantity of Lime and Fertilizer Mixed Grade

Lime and fertilizer are measured by the ton (megagram). Lime used as a filler in fertilizer is measured by the ton (megagram).

F. Quantity of Nitrogen Used for Permanent Grassing

Nitrogen is measured in pounds (kilograms) based on the weight of fertilizer used and its nitrogen content.

G. Replanting and Plant Establishments

No measurement for payment is made for any materials or work required under [Subsection 700.3.06](#) and [Subsection 700.3.07](#).

H. Temporary Grass

Temporary grass is measured for payment by the acre (hectare) according to [Section 163](#).

I. Seeded Native Restoration Areas, Multitropic Native Planting Areas, Riparian Areas, Stream Restoration Areas, and Wetland and Stream Mitigation Areas

Seeded Native Restoration Areas, Multitropic Native Planting Areas, Riparian areas, Stream Restoration area, and Wetland and Stream Mitigation areas will be measured by the acre (hectare), and included under the pay item "Native Restoration and Riparian Seeding".

700.4.01 Limits

General Provisions 101 through 150.

700.5 Payment

As grassing and planting progress, the Contractor will receive full measurement and payment on regular monthly estimates provided the work complies with the Specifications.

A. Permanent Grassing (Native Seed Mixes)

Permanent grassing will be paid for at the Contract Price per acre (hectare), complete and in place. Payment is full compensation for preparing the ground, seeding, wood fiber mulch, polyacrylamide, and providing plant establishment, soil tests and other incidentals.

B. Straw or Hay Mulch

Straw or hay mulch required for Permanent Grassing will be paid for according to [Section 163](#).

C. Fertilizer Mixed Grade

Fertilizer mixed grade will be paid for at the Contract Price per ton (megagram). Payment is full compensation for furnishing and applying the material.

D. Lime

Lime will be paid for at the Contract Price per ton (megagram). Lime used as filler in fertilizer will be paid for per ton (megagram). Payment is full compensation for furnishing and applying the material.

E. Nitrogen

Nitrogen will be paid for at the Contract Price per pound (kilogram) of nitrogen content. Payment is full compensation for furnishing and applying the material.

F. Sod

Sod will be paid by the square yard (meter) in accordance with the following schedule of payments. Payment is full compensation for ground preparation, including addition of topsoil, furnishing and installing live sod, and for Plant Establishment.

1. 70% of the Contract Price per square yard will be paid at the satisfactory completion of the installation.
2. 20% of the Contract Price will be paid upon satisfactory review of sod which is healthy, weed free and viable at the inspection made at the end of the first spring after installation...
3. 10% of the contract price will be paid upon satisfactory review of sod that is healthy, weed free and viable at the Final Acceptance.

G. Temporary Grass

Temporary Grass will be paid for under [Section 163](#).

H. Seeded Native Restoration Areas, Multitropic Native Planting Areas, Riparian Areas, Stream Restoration Areas, and Wetland and Stream Mitigation Areas

Seeded Native Restoration Areas, Multitropic Native Planting Areas, Riparian areas, Stream Res-

toration area, and Wetland and Stream Mitigation areas will be paid for at the Contract Price per acre (hectare), complete and in place. Payment is full compensation for preparing the ground, seeding, and providing plant establishment and other incidentals. and included under the pay item "Native Restoration and Riparian Seeding".

Payment will be made under:

Item No. 700	Permanent grassing	Per acre (hectare)
Item No. 700	Agricultural lime	Per ton (megagram)
Item No. 700	Fertilizer mixed grade	Per ton (megagram)
Item No. 700	Fertilizer nitrogen content	Per pound (kilogram)
Item No. 700	Sod	Per square yard (meter)
Item No. 700	Native Restoration and Riparian Seeding	Per acre (hectare)

700.5.01 Adjustments

General Provisions 101 through 150.

END OF SECTION

State Road and Tollway Authority (SRTA), State of Georgia

SPECIAL PROVISION

Section 701 – Wildflower Seeding

701.1 General Description

This work includes preparing the ground, furnishing and planting wildflower and companion grass seeds, applying fertilizer, and applying lime, if necessary, to areas designated on the Plans.

701.1.1 Definitions

General Provisions 101 through 150.

701.1.2 Related References

A. Standard Specifications

[Section 882—Lime](#)

[Section 890—Seed and Sod](#)

[Section 891—Fertilizers](#)

B. Referenced Documents

General Provisions 101 through 150.

701.1.3 Submittals

General Provisions 101 through 150.

701.2 Materials

A. General

Use materials that meet the requirements of the following Specifications:

Material	Specification
Agricultural Lime	<u>882.2.01</u>
Companion Grass Seed	<u>890.2.01</u>
Fertilizers	<u>891.2.01</u>

B. Wildflower Seed

Use seed from the latest season's crop.

Use seed that meets the minimum germination rates listed in the Wildflower Seeding Table with 100 percent seed purity. Proportion seed mixture according to the Wildflower Seeding Table. Seed by Applewood Seed Company or approved equal. Contractor to apply by hydroseed with native seed grass See Section 700 Grasses. Apply native seed grasses at 10 lbs. per acre and wildflowers at 4.5 lbs. per acre.

Wildflower Seeding Table

Approx. % by Weight	Botanical Name	Common Name	% Germination
2.49	Aster novae-angliae	Aster, New England	100% Pure Seed
11.47	Asclepias syriaca	Butterfly Milkweed	100% Pure Seed
38.24	Coreopsis lanceolata	Lance-leaved Coreopsis	100% Pure Seed
38.24	Lupinus perennis	Lupine, Perennial	100% Pure Seed
7.65	Rudbeckia 'Goldstrum'	Black-Eyed Susan	100% Pure Seed
1.91	Vernonia fasciculata	Ironweed, Prairie	100% Pure Seed

C. Companion Grass

- A. Companion Grass: Southeast Native Seed Grass Mixture (SEGR) by Applewood Seed Company or approved equal. Apply by hydroseed at 10 lbs. per acre with wildflower seed mixture at 4.5 lbs. per acre.

Botanical Name	Common Name	% Germination
Andropogon virginicus	Broomsedge	100% Pure Seed
Elymus virginicus	Virginia Wildrye	100% Pure Seed
Schizachyrium scoparium	Little Bluestem	100% Pure Seed
Tridens flavus	Purpletop	100% Pure Seed

D. Fertilizer Mixed Grade

Select fertilizer mixed grade such as 10-10-10, 6-12-12, 5-10-15, or any other analysis within the following limits:

- Nitrogen 5 to 10 percent, phosphorus 10 to 15 percent, and potassium 10 to 15 percent

701.2.01 Storage, Delivery, and Handling

Use seed delivered in original sealed packages bearing the producer's guaranteed analysis for percentages of species mixture, minimum germination rates, and purity of seed.

701.3 Construction Requirements**701.3.1 Personnel**

General Provisions 101 through 150.

701.3.2 Equipment

Use approved mechanical seed drills, drop spreaders, and rotary spreaders to distribute seed.

701.3.3 Preparation**A. Planting Limits**

Before preparing the ground, stake planting limits according to the Plans and as approved by the Engineer.

701.3.4 Fabrication

General Provisions 101 through 150.

701.3.5 Construction

A. Ground Preparation

Prepare the ground as follows:

1. Plow between 4 in to 6 in (100 mm to 150 mm) deep.
2. After plowing, thoroughly disk the area until pulverized, then smooth the surface.
3. Remove large clods, boulders, stumps, rocks, and other foreign particles that will interfere with the work and seedling growth.
4. Wait 2 weeks after preparation, then spray new growth with 1 gal per acre (9 L per hectare) of Roundup™ herbicide.
5. Wait at least 10 days before proceeding.

B. Application of Lime and Fertilizer Mixed Grade

Apply lime and fertilizer as follows:

1. Lime
Uniformly spread agricultural lime on the ground at the approximate rate determined by the Engineer. If the pH is 6.0 or higher, no lime is required.
2. Fertilizer Mixed Grade
Spread the fertilizer, mixed according to [Subsection 701.2.D](#), uniformly over the ground at approximately 200 lbs/acre (225 kg/ha).
3. Mixing
Before doing further work on the area, blend the lime and fertilizer uniformly into the top 4 in (100 mm) of soil using harrows, rotary tillers, and other equipment approved by the Engineer.

C. Seeding

Weather permitting, sow seed within 24 hours of applying the fertilizer and lime to the seed bed as follows:

1. Sow seed uniformly according to the rate specified in [Subsection 701.2.B](#). Use approved mechanical seed drills or mix seed with dry sand and spread it with either a drop spreader or rotary spreader.
2. Cover the seed to no more than 1/8 in (3 mm) deep.
3. After seeding, roll the area with a cultipacker or similar equipment to ensure good soil contact for seedling germination.

D. Mulching

After rolling the seed bed, apply 1 ton per acre (2 Mg per hectare) of wood fiber mulch.

701.3.6 Quality Acceptance**A. Replanting**

The Engineer may require replanting an area that shows unsatisfactory growth.

Except as otherwise specified by the Engineer, prepare replanting areas the same as the initial planting with the following exception:

- Use a soil test or the Engineer's guidance to determine the fertilizer type and application rate, then furnish and apply the fertilizer.

B. Providing Growth and Coverage

Ensure that wildflower growth and coverage conforms with the intent of the Contract for the vegetation, except for seed not expected to germinate and show growth at that time.

Ensure that vegetation shows a satisfactory visible growth with no bare spots larger than 1 ft² (0.1 m²). Bare spots shall be infrequent, comprising no more than 1 percent of a given area.

701.3.7 Contractor Warranty and Maintenance**A. Plant Establishment**

Preserve, protect, water, reseed or replant, and perform other work as necessary to keep the

wildflower areas in satisfactory condition.

B. Watering

Keep planted areas moist for 4 to 6 weeks during seedling germination and development.

Following initial growth, water the wildflower areas enough to promote maximum growth.

C. Mowing

Mow once a year in late fall after seedheads have matured. Avoid damaging desirable vegetation.

701.4 Measurement

A. Wildflower Seeding

The number of acres (hectares) completed according to the above requirements and accepted by the Engineer is measured for payment.

B. Wood Fiber Mulch

Mulch furnished and applied is not measured separately.

C. Water

Water furnished and applied to promote a satisfactory growth is not measured for payment.

D. Agricultural Lime

Lime is measured by the ton (megagram).

E. Mixed Grade Fertilizer

Fertilizer is measured by the pound (kilogram).

701.4.01 Limits

Work required under Subsection 701.3.06 and Subsection 701.3.07 is not measured for payment.

701.5 Payment

Wildflower seeded areas will be paid for as follows:

A. Wildflower Seeding

When plants are satisfactorily planted, 80 percent of the Contract Unit Price bid per acre (hectare) will be paid on the next estimate.

Until Final Acceptance, perform required maintenance according to [Subsection 701.3.07](#) when necessary or as ordered by the Engineer.

At Final Acceptance, the remaining 20 percent will be paid. Payment is full compensation for preparing ground, providing wildflower and companion grass seed, applying seed, watering, mulching, and establishing plants.

B. Mixed Grade Fertilizer

Fertilizer will be paid for at the Contract Price per pound (kilogram). Payment is full compensation for furnishing and applying the material.

C. Lime

Lime will be paid for at the Contract Price per ton (megagram). Payment is full compensation for furnishing and applying the material.

Payment will be made under:

Item No. 701	Wildflower seeding	Per acre (hectare)
Item No. 701	Fertilizer mixed grade	Per pound (kilogram)

Item No. 701	Agricultural lime	Per ton (megagram)
--------------	-------------------	--------------------

701.5.01 Adjustments

General Provisions 101 through 150.

END OF SECTION

State Road and Tollway Authority (SRTA), State of Georgia

SPECIAL PROVISION

Section 702 – Vine, Shrub and Tree Planting

702.1 General Description

- A. This work includes furnishing and planting vines, shrubs, trees and plants, and Landscape Maintenance Bond requirements.
- B. Related Work: Drawings and general provisions of the contract, including General Conditions and Standard Specification sections apply to this section.

702.1.1 Definitions

General Provisions 101 through 150.

702.1.2 Related References

C. Standard Specifications

Section 108—Prosecution and Progress

Section 214—Mitigation Site Construction

Section 700—Grassing

Section 708—Plant Topsoil

Section 882—Lime

Section 891—Fertilizers

Section 893—Miscellaneous Planting Materials

D. Referenced Documents

Standardized Plant Names

ANSI A300 Part 1 Pruning Standards

ANSI Z60.1 American Standards for Nursery Stock

702.1.3 Submittals

A. Certificates of Inspection

Submit certificates of inspection with the invoice for each shipment of plants as required by law for transportation.

File certificates with the Engineer before the material is accepted. Plants may be rejected at the site regardless of Federal or State government inspections at the place of growth.

B. Substitutions

When both primary and alternate plants are specified, use the alternate only after providing written proof that the primary plants specified are not available. In this case a Supplemental Agreement is not required to use the alternate plants.

When a primary or an alternate plant cannot be furnished, provide the Engineer written proof that neither is available. A Supplemental Agreement is required for substitute plants in this case.

Use approved substitute plants, as designated by the Engineer, equal in value to specified plants.

Request substitutions at least thirty (30) days before the end of the planting season in the area.

C. Contractor Submittal of Landscape Nursery Material

The Contractor shall furnish field-grown trees complying with ANSI Z60.1, with healthy root systems developed by root pruning and transplanting. Provide well-shaped, fully branched, healthy, vigorous stock free of disease, insects, eggs, larvae, and defects such as knots, sun scald, injuries, abrasions, and disfigurement. Provide written verification and photos of ten representative trees from the supplying nursery for review with the submittal. Provide a photograph of a sample tree root system with the submittal.

1. Furnish trees with the following characteristics:

Root System Development:

- a. 100% mechanically root pruned with a vibrating blade during the first three years of the tree's life.
- b. Trees shall have been field grown in heavy clay soil and irrigated with drip irrigation.
- c. Trunk flare shall be visible above ground from the nursery.

Canopy Development

- a. Strong central leader to the top of the canopy. The tip of the leader on the main trunk must be intact and its terminal bud must be the highest part of the tree.
 - b. No branch shall have a diameter greater than 2/3 of the trunk diameter measured directly above the branch crotch. The tree crown must be structurally uniform. Branches shall be evenly distributed around the trunk. The crown shall be full of foliage which is evenly distributed around the tree.
2. **Root-Ball Depth:** Furnish trees and shrubs with root balls measured from top of rootball, which shall begin at root flare according to ANSI Z60.1.
 3. Provide photos of tree root system meeting the requirements above 7 days prior to bid date for landscape architect's approval. Provide signed statement from grower describing root-pruning history & include grower name, contact, address, and phone number.
 4. Landscape contractor shall submit confirmed order and documentation to landscape architect for trees within 15 business days of the bid award of the general contractor.

702.2 Materials

Ensure that materials meet the requirements of the following Specifications:

Material	Section
Water	700.2.B
Agricultural Lime	882.2.01
Fertilizers	891.2.01
Plant Topsoil	893.2.01
Landscape Mulch	893.2.02
Vines, Shrubs, Trees, and Miscellaneous	893.2.03
Tree Paint	893.2.06
Prepared Plant Topsoil	893.2.07
Stakes	893.2.08
Organic Soil Additives	893.2.09

A. Plant Specifications

Furnish plants according to the plant name and Specifications included on the plan sheets.

- I. Plant Names

Ensure that the botanical and common names of plants specified conform to the most current edition of Standardized Plant Names, as adopted by the American Joint Committee on Horti-

- cultural Nomenclature.
2. Plants should be clearly labeled at the nursery. Labels should remain on the plants until inspected by the engineer.
 3. Grades

Ensure that plants meet the grade requirements of the most current American Nursery and Landscape Association ANSI Z60.1 and any other requirements.

Caliper used for establishing plant grades or trunk sizes is measured according to the American Nursery and Landscape Association ANSI Z60.1. Plant trees with straight stems and symmetrical branches according to their natural growth. Trees with broken or damaged terminal or main stems will be rejected. There shall be a single dominant leader to the top of the all large canopy shade trees. There can be a double leader in the top 10% of the tree height. Trees should be rooting into the root ball so that soil or media remains intact and trunk and root ball move as one when lifted, but not root bound. The trunk should bend when gently pushed and should not be loose so it pivots at or below the soil line.

There shall be no roots greater than 1/10 diameter of the trunk circling more than one-third the way around in the top half of the root ball. Roots larger than this may be cut provided they are smaller than one-third the trunk diameter.

The leaf-bearing crown should be full and uniform. Leaves should show no evidence of chlorosis, necrosis, disease or insect infestation.

B. Bare root seedlings

Use nursery-grown bare root seedlings which are a minimum of three (3) feet (1 meter) in height above the ground with a 1/4 inch (6.35mm) caliper, and a minimum primary root length of five inches (5) unless specified differently on the plan drawings.

Use approved substitute plants, as designated by the Engineer, equal in value to specified plants. Request substitutions at least 30 calendar days before the end of the planting season in the area. Wet swale bare root *Juncus effuses* shall be fresh divisions with a full, dense root base.

C. Nursery Plants

Unless otherwise specified, use plants stock-grown in a licensed nursery under intensive care and cultivation for at least one year. The largest branches of shade trees should be spaced at least 6 inches apart. The branch system shall be normally developed and free of disease, injurious insects, disfiguring knots, sun-scald, injuries, bark abrasions, dead or dry wood, broken terminal growth, or other disfigurements. Stems should show no evidence of die-back. Ensure that proper certificates of inspection and a complete list of the nursery growers accompany nursery grown plants. See Subsection 893.2.03.

D. Plant Topsoil

Plant topsoil mix shall contain topsoil defined within the Section 893. Organic soil additives shall not exceed 50% of the mixture. All organic soil additives shall be fully composted. Contractor shall submit samples of the proposed soil mix for approval. See section 893.

E. Approval and Selection of Materials and Work

Select materials and execute operations required under the Specifications and drawings with the approval of the Engineer. Remove rejected materials from the site promptly.

702.2.01 Delivery, Storage, and Handling

A. Bare-Rooted Plants

Protect bare root plants from drying out until planted. Uncovered roots without moisture-loss gel coating shall be exposed to air no longer than 15 minutes.

B. Balled and Burlapped Plants (B&B)

1. Burlap shall be a natural biodegradable material. Do not use synthetic burlap.
2. Replace plants rejected because of broken or loose balls, or balls of less diameter than that specified.
3. Protect the roots of balled and burlapped plants from moisture loss, unless they are planted immediately after they are delivered.
4. Plants shall be harvested with the ball of earth in which they are growing intact.

C. Container-Grown Plants

Keep container-grown plants moist but well drained until planted. Handle plants by the container or soil ball and not by the top growth.

D. Heeled-in Plants

Properly maintain heeled-in plants until they are planted. Do not allow plants to remain heeled-in over the summer or for over 30 days without the Engineer's consent.

E. Injury Prevention

Injured plants will be rejected. Protect tops of shrubs and trees while in transit to prevent windburn.

702.3 Construction Requirements**702.3.1 Personnel**

General Provisions 101 through 150.

702.3.2 Equipment

General Provisions 101 through 150.

702.3.3 Preparation**A. Inspect Plant Material before Digging**

The Engineer will inspect trees or plants from the bidder's source for acceptability and conformity to specification requirements for approval by the Engineer. When rejecting the trees or plants, the Engineer reserves the right to pursue and examine other sources of plants to find acceptable specimens. This change will not constitute an increase in cost to the State.

B. Clear and Grub

Clear and grub the planting area before planting or beginning to prepare the plant bed, unless noted differently on the plans. See Section 201.

C. Prepare Plant Bed

Prepare for planting as follows:

1. Planting Limits

Stake planting limits according to Plan details and the Engineer. Have the Engineer approve the method of plant identification before planting.

For median plantings, keep any woody plant a minimum of 3 feet (1m) from the edge of the plant bed to avoid vegetative growth into the roadway.

For stream buffers identified as "Stream Buffer" or "wet swales", on plans, the plant species shall be planted in a random, intermixed manner throughout the entire planting area. At the edges of the planting zone, keep new plants a minimum of 8 feet (2.4m) from existing trees or permanent structures.

2. Applications of Soil Additives

- a. Apply fertilizer and lime to the plant bed according to the soil test report.
- b. Spread an organic soil additive, (See Subsection 893.2.09), evenly throughout the design-

nated area to at least 2 in (50 mm) deep. Thoroughly dig it into the soil to at least 6 in (150 mm) deep using a rotary hoe type tiller or other equipment that evenly mixes the soil, lime, fertilizer, and organic soil additive.

- c. Till the area until the surface is smooth and free of weeds, roots, rocks, and other debris, to the satisfaction of the Engineer.
- d. If the planting area lies within a multitrophic native planting area, stream buffer, wetland, wet swale, or marsh the addition of fertilizer or lime is prohibited.

702.3.4 Fabrication

General Provisions 101 through 150.

702.3.5 Construction

A. Seasonal Limitations for Planting

For geographic seasonal limitations, refer to the Planting Zones Map found in Subsection 700.3.05. Plant in Zones 1 and 2 between October 15 and March 15. Plant in Zones 3 and 4 between November 1 and January 1.

B. Planting Operations

Plant using the method called for on the details and plan sheets. Before beginning planting of each area, have available the necessary materials including prepared plant topsoil (see Subsection 893.2.07), water, stakes, and mulch. Plants shall be installed as straight/upright as possible. Any plants found to be leaning or broken will not be accepted or paid for by the engineer.

When seasonal limitations and weather conditions permit, continuously water, mulch, guy, provide tree guards, and stake as indicated on the plans and details until completing the last operation.

After completing planting, provide a method for retaining water adjacent to the plant according to the details shown on the Plans or as directed by the Engineer.

Protect marsh restoration areas from vehicles and machinery. Typical protective barriers are not to be used in tidal areas. Stakes that remain secure and are taller than the highest tide, flagged with highly visible flagging tape, are required to mark the area to be protected and off-limits for vehicles and machinery.

1. Planting By the Pit Method

a. Placing Bare-Rooted Plants

Plant bare-rooted plants delivered to the pit area. Protect roots from drying out until placing them in the pit.

1. Center plants in pits and spread roots as they originally grew.
2. Cover and prepare the topsoil according to details shown on the Plans.

b. Placing Balled and Burlapped Plants

Immediately plant these plants after they are delivered to the pit site.

1. The pit diameter shall be a minimum of 3 times the diameter of the rootball. Center the ball in the prepared pit, leaving the top of the ball 1 in (25 mm) above the top of the ground for settlement.
2. Cut away and remove the top 1/3 of burlap from the rootball. Cut all ropes and twine, pull the nails, and drop the remaining burlap to the bottom of the hole. Cut away and remove all wire from the root ball.
3. Partially fill the pit with prepared plant topsoil and compact the soil enough to hold the ball firmly. Add mycorrhizal inoculant to plant topsoil if specified in plans.
4. Equipment: Whenever possible a telehandler with side-tilt carriage forks (brands such as LULL or JLG) machine rated to handle weights of root balls and trees should be used to set root balls in planting pits. Forks should always be carefully positioned above root ball to lift root ball by strapping on top of the root ball with four pick-up points for even weight distribution. Prior to setting root ball in planting pit, forks should be adjusted so that tree is plumb. Place root ball at a level where

trunk flare will be 1 to 2" above surrounding finished grade after settling.

5. **Backfill / Water:** Backfill and tamp in 6" lifts until ½ complete. Saturate the planting hole with water. After ½ backfill, watering, and the tree is plumb, then add backfill to just below the top horizontal ring of the wire basket, completely saturate planting hole. Adjust root ball (if necessary) by adjusting forks to make tree straight and plumb and at proper depth. Do not remove forks until tree is straight and plumb, backfill is settled, and root ball is stable.
6. **Remove Forks:** After above items have been completed and tree is straight and plumb with root ball stable and at proper depth, gently remove forks and also remove:
 - a. The synthetic strap
 - b. Any cardboard packaging,
 - c. The top portion of the wire basket down to and including the first horizontal ring,
 - d. The burlap from the top portion of the root ball.
7. **Backfill / Water:** Complete the backfill and thoroughly saturate with water, repeat this step if necessary to make absolutely certain that air pockets do not exist in the backfill.
8. **When soil on top of root ball is distorted or not perpendicular to tree trunk:** Even root balls with excellent root systems grown and harvested at proper depth can sometimes become distorted during shipping and handling.

Actions to take if soil on top of root ball has become distorted:

- A. **If soil is bulging or distorted on the top surface of the root ball:**
 - i. Very gently tamp the area of bulging or distorted soil as much as possible so that soil is perpendicular to trunk.
 - ii. If soil is still bulging or distorted, very gently (with a sharp shovel or spade) cut and remove remaining bulge.
- B. **Root ball distortion can be minimized by:**
 - i. Providing as much advance notice as possible so that select trees will be able to best manage soil moisture during harvest, loading, and shipping.
 - ii. Coordinating scheduling so that trees will not be shipped during significant rain.
 - iii. Following the previous handling planting and care instructions.

When a tree is handled, moved, adjusted, straightened, etc. more than the minimum steps covered in these instructions, the possibility of root ball distortion and other damage increases. Root balls that are moved when extremely wet are the most likely to become distorted or damaged.

9. **Staking:** Immediately after backfill has settled & the tree is straight & plumb, stake tree to provide stability until root system is thoroughly established in the backfill. Check staking as needed to make sure trunk damage does not occur. Check to confirm that tree and root ball are stable before removing staking.
10. **Mulch:** Mulch the area over the root ball to a depth no deeper than 1 ½" to 2". Keep all mulch away from the trunk flare.
11. **Straightening:** If for any reason trees need straightening, trees can be straightened by carefully digging out all backfill around the root ball, attaching seat belt strap to the wire basket and lifting. Never pull, push, or put pressure on the trunk (refer to actions B.3 – B.12 for information to complete this process). If tree roots are significantly established in the backfill, it is best for the health of the trees to wait until dormancy to straighten trees, since roots outside the original root ball will be cut.

c. **Placing Container-Grown Plants**

When the container is delivered to the pit site, split the container from top to bottom and

carefully remove the plant.

1. The pit diameter shall be a minimum of 3 times the diameter of the rootball. Spread into the hole any major roots growing around the container or prune them to remove any circular growth.
 2. Place the ball in the center of the prepared pit, leaving the top of the ball 1 in (25 mm) above the top of the ground for settlement.
 3. Partially fill the pit with prepared plant topsoil and compact the soil enough to hold the ball firmly. Add mycorrhizal inoculant to plant topsoil if specified in plans.
- d. **Completing Pit Plantings**
After placing pit plantings, water plants thoroughly the same day regardless of weather or soil moisture conditions.
1. After the water has soaked in, add prepared plant topsoil and compact firmly up to 2 in (50mm) below the adjacent ground.
 2. Stop compacting when the compacted prepared topsoil is 2 in (50 mm) below the adjacent ground.
 3. Fill the remainder of each pit with loose, prepared plant topsoil according to the details shown on the Plans.
 4. Prepare the loose topsoil to retain water adjacent to the plant according to the Plans or as directed by the Engineer.
2. **Planting using a Dibble, Hoedad, or Reinforced Planting Shovel for Wet Swale and Bare Root Seedlings.** Planting shall only be done when there is adequate moisture in the ground and when the ground is not frozen.
- Provide proper root positioning and contact with the soil, and eliminate all air pockets around roots. Roots of seedlings shall not be pinched or bent in a sideways or upturned direction.
- Each tree, division, or seedling shall be inserted into the hole such that the root collar of the tree will be at ground level after backfilling is complete. Allowance for burying the root collar below ground level shall not exceed one-half inch in depth. In no case shall planting result in the root collar remaining above ground level. The soil back-filled around the root system shall be compacted sufficiently to support the plant. Mow or use a string trimmer to a height of 1 in (25 mm) in the area designated for restoration. Do not trim wet swales or retention basins where standing water is present.
- Grass the area designated for restoration with a native restoration or riparian seed mix and apply wheat straw mulch to the area before planting seedlings.
- Plant within 48 hours after mowing or string trimming the site.
3. Restoration and enhancement of tidal marsh areas are subject to possible wave energy, requiring the use of a plant anchor for each plant. See planting plan sheets and details for plant anchor and anchoring descriptions.

C. Landscape Mulching

1. For Pit Plantings

Follow these requirements when mulching for pit plantings:

- a. Where the distance between plants is 8 ft (2.4 m) or less, spread mulch throughout and 3 ft (900 mm) beyond the outermost plants. Where plants are more than 8 ft (2.4 m) apart, apply mulch in a circular fashion around each plant, forming a ring 5 ft (1.5 m) in the outside diameter.
- b. If plant pits are greater than 5 ft (1.5 m) in diameter, ensure that the mulch extends out to cover the berm as shown in the planting details on the Plans.
- c. Apply mulch within 3 days of planting at least 4 in (100 mm) in depth to obtain a compacted depth of at least 3 in (75 mm).
- d. Compaction occurs naturally. Check compaction at least two months after spreading and

- e. exposing the mulch to the elements.
 - f. If the compacted depth is less than 3 in (75 mm), apply additional mulch to deficient areas within 1 month following notification.
 - g. Apply mulch to a uniform depth and remove lumps for a neat appearance. Tuck mulch neatly against all paving edges, drainage structures, and where planting beds meet grassed areas.
 - h. Leave a 1 in (25 mm) to 2 in (50 mm) ring of non-mulched area directly around all tree trunks.
 - i. Do not mulch with Cypress Mulch.
- 2. For Plantings using a Dibble, Hoedad, or Reinforced Shovel
 - Apply landscape mulch according to Subsection 702.3.05.C.1 with the following exceptions:
 - a. Apply mulch before planting.
 - b. Use only wheat straw mulch in restoration areas.
 - c. Ensure that the mulch coverage is open enough to allow seed germination to take place and dense enough to conserve moisture in the seed bed.
- 3. For Native Multitrophic or Stream Buffer Restoration Planting Areas, wheat straw shall be the only types of mulch used.
- 4. Do not mulch wet swale or retention ponds where standing water is present.

D. Wrapping

Do not wrap the trunks of tree unless specified in the plans. When wrapping is specified, tightly wrap the trunks of deciduous trees over 1.25 in (32 mm) in caliper. Wrap in strip burlap or waterproof crepe tree wrapping paper or other approved materials.

- 1. Begin wrapping at the ground and extend spirally up and beyond the first rosette of branches with an overlap of one half the width of the wrapping material.
- 2. Tie the wrapping material securely with binder twine spaced every 12 in (300 mm) for the full length of the wrapping. Wrap immediately after planting.

E. Staking and Guying

- 1. Do not use staking and guying unless specified in the plans or details.
- 2. Perimeter Staking
 - 3. Place perimeter stakes 2 in x 2 in x 36 in (50 mm x 50 mm x 900 mm). Stake the perimeter of indicated regenerated areas within specified planting dates according to the Plans or as directed by the Engineer. Place as many stakes as necessary to keep trees and rootball straight, upright, and plumb.
- 4. Vine, Shrub, and Miscellaneous Plant Staking
 - 5. Use stakes to identify isolated vines, shrubs, and miscellaneous plants outside of solid mulched beds according to Plan details.
- 6. Tree Staking and Guying
 - 7. Stake trees using a system that will prevent trees from leaning or tilting and keep the root ball stable until the roots become anchored. The system should allow the top some movement and flexibility without damaging the tree. Nylon guying straps of accepted size and quality shall be used.
 - 8. Replace at no additional expense to the Department, any staking and guying materials that break or loosen.

F. Pruning

- 1. Prune plants on the site before planting and after initial inspection by the Engineer as needed for the health of the plant. Never prune severely to get plants to meet Specifications.

- a. Follow ANSI A300 Part 1 standards and use approved tools designed for pruning.
- b. Lopping, topping, or shearing trees or shrubs is not permitted.
- c. Prune back damaged, scarred, frayed, split, and skinned branches, limbs, and roots to live wood nearest to the next sound, outside lateral bud, branch, limb, or root.
- d. Leave the terminal leaders or buds in trees intact.
- e. Prune roots, when necessary, as directed by the Engineer.
- f. Prune Grape Myrtles to maintain natural form only. Severely cutting back or stump pruning crape myrtles is not permitted. Remove sucker growth from Grape Myrtles.
- g. Damaged, scarred, frayed, split and skinned branches, limbs and roots shall be pruned back to live wood nearest to the next viable outside lateral bud, branch, limb or root.

G. Watering

1. Apply water in a manner to prevent erosion. Water plants deeply and thoroughly at the time of planting. Water after applying fertilizer called for in Subsection 702.3.05.H and as necessary to maintain enough moisture to promote plant growth.
 - a. Apply enough water to wet the soil to a depth slightly below the roots. Direct the water to the ground around the plant, not the tops.
 - b. Do not allow plant foliage to dry out or plants to defoliate from lack of water. Remove plants in such condition from the site immediately. Apply supplemental watering to maintain vigorous growth and to keep plants moist and as directed by the Engineer.
 - c. Apply water once per week throughout the planting season in which the plants are installed. Follow Subsection 702.3.07.B and 702.3.07.C for shrub and tree watering requirements throughout the life of the project.
 - d. If required irrigation water shall be transported via watering truck and administered by hand watering.
 - e. The Contractor is responsible for monitoring all plant material vitality, soil moisture level, and climatic conditions as they pertain to watering. Maintain accurate rainfall measurements for Project until Final Inspection and until expiration of Landscape Maintenance Bond. The Contractor shall install and maintain a minimum of three (3) rain gauges spaced evenly along Project.

H. Spring Application of Fertilizer

1. Method and Rate of Application

Follow these requirements when applying fertilizer in the spring:

- a. Trees

Apply a slow-release fertilizer according to soil test results. Assume 8-12-12 with a rate of 1 cup (0.25 L) per caliper inch of tree for bidding purposes.
- b. Shrubs and vines

Fertilize shrubs according to soil test results with a slow release fertilizer by spreading fertilizer around the base of the plant and working it into the soil by hand. Assume 6-12-12 with a rate of 0.5 cup (0.12 L) per foot of shrub height for bidding purposes.

Bed Areas

Spread fertilizer on bed areas (defined by method of planting in Subsection 702.3.05.B), over the mulch according to soil test results. Assume 3 lbs/100ft² of 6-12-12 for bidding purposes. Thoroughly water in the plants.
- c. Native Restoration or Stream Buffer Areas

The addition of fertilizer or lime is prohibited within the native restoration or stream buffer planting areas.

2. Time of Spring Fertilizer Application

Apply fertilizer in the spring in Zones 1 and 2 (with reference to the Planting Zones specified in Subsection 702.3.05.A) between April 1 and April 15. Apply between March 15 and April 1

for Zones 3 and 4. For late plantings, do not apply fertilizer less than 30 days after the plantings.

3. Additional Fertilizer

Approximately one month after the spring fertilizer is applied; the Engineer will inspect planted areas and determine if an additional application of fertilizer is needed for any plant or group of plants.

If the Engineer determines additional fertilizer is required, apply fertilizer according to soil test results between June 15 and July 15th.

I. Tree Guards for Stream Buffer Saplings

Each planted bare root, sapling-sized plant shall be fitted with a tree guard to protect the saplings from wildlife browsing. The tree guards shall be at least 36 inches tall, with appropriately sized wooden stakes or bamboo to securely support the tree guard [i.e., a 4-foot (1.2 meter) stake for a 36 inch (914.4 mm) guard]. Mesh tube-type tree guards are required.

Vexar tubes, or equivalent, are to be used. All tree guards shall be removed from the saplings at final inspection.

J. Restoration and Cleanup

Restore areas where existing grass has been damaged or scarred during planting operations at no expense to the Department. Restore the disturbed areas to their original conditions as directed by the Engineer. Clean up debris, spoil piles, and containers and leave the Project area clean.

Clean up and remove all debris, spoil piles, containers, water reservoirs, trash, etc. and leave the project area in an acceptable condition. Inspect all installed erosion control devices weekly and clean out or repair as required. Remove all erosion control devices at final acceptance unless otherwise instructed by the Engineer.

702.3.6 Quality Acceptance

Preserve the plants in a healthy growing condition and keep plants moist, particularly during drought conditions (no rain for any two week period). The acceptability of the plant material planted and maintained as specified will be determined at the end of a warranty and landscape maintenance bond period.

Plant all plants in one planting season unless otherwise approved by Engineer.

A. Final Inspection

The Department will make the final inspection of the plants during May, following any needed re-placements during the previous planting season. Assume responsibility for the plants until the Final Acceptance of the Project or a portion of the Project.

702.3.7 Contractor Warranty and Landscape Maintenance Bond Requirements

The Contractor guarantees and will replace, at no additional cost to the owner, 100% of the plants which, in the opinion of the landscape architect/ Owner representative, fail to maintain a healthy, vigorous condition for the entire (1) one-year warranty starting after final acceptance of the project. Landscape Maintenance Bond shall be for one-year starting after final acceptance of the project. The Landscape Maintenance Bond includes maintenance as outlined in this special provision. The Landscape Maintenance Bond also includes maintaining all sod, seeded areas, and wildflower areas, refer to Plans and Special Provision Section 700 – Grassing (Sodding and Seeding) and Special Provision Section 701 – Wildflower Seeding. Replacement plant material shall meet all specifications as listed in the drawings and on the plant list in regard to species, variety, color, and quality. Size of replacement plant material shall equal that of the plant which is being replaced and/or the size of existing adjacent like specimens.

The Contractor is responsible for "treating" problem plant material and shall outline immediate steps to correct problems or improve performance of the plant.

In the event that the performance of the landscape maintenance contractor should fail to satisfy

the expectations and standards set forth in the maintenance specifications as interpreted by the owner and the landscape architect, the owner reserves the right to obtain others to perform such duties and/or not release the landscape maintenance bond.

Inspections: The owner, or the designated owner's representative, will make periodic reviews of the entire site as related to visual aspects and the contractor's performance. The contractor will, on the sole judgment of the designated representative, make repairs and adjustments as directed during the site visit.

Schedule: Prior to starting this contract the contractor will provide the owner with a detailed schedule of how he expects to accomplish this work/maintenance along with a statement of anticipated labor forces. The schedule is to include target dates for all cycle and periodic work, time estimates for task completion, staffing requirements, etc...

Project maintenance includes, but is not limited to, mowing, edging, watering, cultivating, weeding, pesticide and herbicide control, pruning, repairing, adjusting guys and stakes, and performing other work as ordered by the Engineer until final acceptance and for the landscape maintenance bond duration.

Promptly remove from the Project area dead plants or those that no longer conform to the requirements of Subsection 702.2.A.2.

Mow sod area of the Project up to a maximum of six times per calendar year. Do not mow native seed mix areas, restoration areas, wet swales, or riparian mitigation sites.

A. Leaning Trees

Straighten leaning trees as directed by the Engineer. Follow Staking and Guying requirements for replacements or repairs as per Subsection 702.3.05.E.

B. Shrub Maintenance

1. Pruning

Prune dead or diseased limbs to provide for plant health and appearance as directed by the Engineer.

2. No regular shrub pruning or maintenance is necessary, as the intent is for shrubs to grow together to form a mass or grouping. Prune or thin shrubs only by direction of landscape architect.

3. Landscape Mulching

Continuously maintain shrub and tree beds with a clean, freshly mulched appearance using the mulch originally specified. See Subsection 702.3.05.C. Do not mulch shrub and tree beds within riparian mitigation sites.

a. Apply a 2 in (50 mm) loose layer of specified mulch (top-dressing) on top of all areas, including tree pits, initially mulched, at the following times:

1. In August and April or as directed by the Engineer.

4. Applying Fertilizer

See Subsection 702.3.05.H.

5. Applying Pesticides

a. Inspect all planted or seeded vegetation for insects, grubs, mites, diseases, etc., once every two weeks. Apply insecticides, fungicides, and herbicides according to the manufacturer's recommendations to effectively control or eradicate the problem.

b. Perform all pesticide applications under the direct supervision of a trained licensed commercial pesticide operator whose license includes sub-category 27 – Right of Way Pest Control. Carry the pesticide license/certification on the work site during applications. Carry all labeling associated with the chemical being applied at the work site.

c. Submit all product information data sheets and EPA approval numbers on all pesticides proposed to be used prior to application for approval.

d. Notify the Engineer a minimum of 48 hours prior to any and all pesticide applications.

e. Add a blue dye to all spray applications unless approved otherwise by the Engineer.

- f. Monitor the weather and spray under proper weather conditions. Spraying shall not occur when the weather is greater than 10 miles per hour.
 - g. Wear the proper safety attire. Wear long sleeve shirts, long pants, gloves, and safety glasses. Wear or use any additional protective safety attire or gear as recommended by the product's manufacturer.
 - h. Repair any damage that is a result of mishandling or misuse of materials, at no expense to the Department, to the satisfaction of the Engineer.
 - i. For stream buffer and marsh restoration areas, pesticides are not to be used unless approved by the Department Ecology Manager.
6. Edging
- a. Edge all shrub pits, shrub beds, and tree pits once a month throughout the life of the project such that the vee-cut edging detail specified on the plans is maintained. Prevent grass and weeds from growing over or into the shrub beds and tree pits.
 - b. Use equipment specifically designed for edging. Line trimming equipment shall not be used.
7. Watering
- a. Check all planted material once a week throughout the contract for dryness by removing the mulch from their base and "sampling the soil" approximately 4 in (100mm) deep. Water if the soil is not moist.
 - b. Water all planted material if a drought (no rain for two weeks) occurs. Provide the water required to meet the watering requirements.
 - c. Water each plant thoroughly until the ground is saturated to a depth slightly below the root ball. Apply water in a manner to prevent erosion.
8. Weed Control
- Perform weed control throughout the project, a minimum of once every two weeks, in all areas within the project limits to maintain tree pits, shrub beds, sidewalks, curb and gutter, walkways, ditch paving, concrete medians, and other pavement weed free. Meet the following conditions:
- a. Perform weed control to prevent weeds from becoming established, setting seed, or from becoming visible in the planting beds.
 - b. Completely remove all undesirable plants (weeds) by hand pulling. Removal of weeds may be accomplished using herbicides if approved by the Engineer. However, the use of herbicides is prohibited in stream buffer areas unless approved by the Department Ecology Manager.
 - c. Apply an approved pre-emergent herbicide twice each year, once in the spring and once in the fall, throughout the contract. The use of pre-emergent herbicides is prohibited in stream buffer areas. Apply pre-emergent to all shrub beds and tree pits. Notify the Engineer 48 hours prior to spraying. Use a blue dye in all applications unless approved otherwise by the Engineer.
 - d. Eradicate all invasive exotic pest plants found within the project limits throughout the life of the project, including stream buffer and marsh areas. Volunteer, non-invasive plant material within stream buffer restoration areas is acceptable.
 - e. Dispose off site on a daily basis all weed, exotic plants, clippings, litter, and debris generated.
9. Policing
- Remove debris such as paper, broken limbs, bottles, cans, etc., a minimum of the first and third week of each month from all areas within the project limits while maintaining the site.
10. Mitigation Areas
- Pruning, mulching, edging, and applying spring fertilizer are not required within wet swales, native restoration areas, stream buffers and regenerated forest areas.

C. Tree Maintenance

1. Watering
See Subsection 702.3.07.B.6
2. Landscape Mulch
See Subsection 702.3.07.B.2
3. Fertilizer
See Subsection 702.3.05.H.
4. Abnormal Conditions
Periodically (once every two weeks) observe trees and shrubs for abnormal conditions such as insects, borers, web worms, red spiders, etc., and immediately treat.
5. Sucker Growth
Remove sucker growth once a month. Sucker growth is the shoots that sprout out around the base of the tree trunk.
6. Pruning and Deadwood
Remove deadwood at least two times a year. Prune dead branches. Paint cuts, and wounds or scars with tree paint only when specified in the plans. Do not top Crape Myrtles. See Subsection 702.3.05.F.
7. Pesticide Control

NOTE: Apply pesticides as necessary to control harmful insects and diseases. Follow the manufacturer's instructions. See Subsection 702.3.07.B.4. NOTE: Use chemicals according to Federal, State and county directives on environmental control that carry an EPA approval number.

8. Weed Control
See Subsection 702.3.07.B
9. Staking and Guying
Remove all support guy wires, strapping and stakes from plants which have gone through one complete growing season.

702.4 Measurement**A. Plants**

Plants of the name and size specified are measured for payment according to the number planted that are still living and viable and in an acceptable condition at the time of Final Acceptance. A viable plant must have a minimum of 75 percent of the leaf-bearing crown with healthy foliage.

B. Fertilizer

Spring application fertilizer applied to planted and regenerated areas will be the actual number of pounds (kilograms) placed and accepted. Fertilizer, lime, and plant topsoil used in prepared plant topsoil or plant bed preparation are not measured for separate payment. For stream buffer and marsh areas, the addition of fertilizer or lime is prohibited.

C. Perimeter Stakes

Perimeter stakes is not measured for payment unless such item is shown as a separate Pay Item in the Proposal.

D. Clearing and Grubbing

Clearing and grubbing is not measured for payment unless the Item is shown as a separate Pay Item in the Proposal.

E. Landscape Mulch

The quantity of landscape mulch and top-dressing measured for payment will be the actual number of square yards (meters) completed as specified and accepted. The presence of weeds or other growth, or foreign material, will be cause for rejection.

702.4.01 Limits

General Provisions 101 through 150.

702.5 Payment**A. Plants**

Plants measured for payment will be paid for as follows:

1. After planting satisfactorily, the Department will pay 80 percent of the Contract Unit Price bid per each on the next estimate.
2. Until Final Acceptance, perform all required maintenance according to Subsection 702.3.07 when necessary or as ordered by the Engineer.

If the Contractor fails to properly maintain the landscaping, daily charges shall be assessed against any money due or that may become due the Contractor in accordance with the schedule of deductions shown in Subsection 108.08, but not less than \$150 per calendar day, and will continue until project maintenance is approved by the Engineer.

The charges are in addition to those specified for delay or failure in completing the Work within the specified time.

3. At Final Acceptance, the Department will pay the remaining 20 percent less the Full Contract Unit Price bid per each plant not accepted.

Payments are full compensation for furnishing, planting, replanting as required, pruning, staking, guying, soil conditioning, and preparing plant beds, including applying additives, digging plant pits, preparing plant topsoil and mulch, disposing of waste material, and maintaining the plants till final acceptance and till the end of the Landscape Maintenance Bond.

B. Fertilizer

All grades of fertilizer applied in the spring, measured as specified above, are paid for at the Contract Price per pound (kilogram) or per ton (megagram), whichever is indicated in the Proposal. Payment is full compensation for furnishing and applying and for watering regenerated areas.

For native restoration, stream buffer and marsh restoration areas, the addition of fertilizer or lime is prohibited.

C. Perimeter Stakes

Perimeter stakes will not be measured for payment. The cost will be included in the overall contract price.

D. Landscape Mulch

Landscape mulch measured for payment will be paid for as follows:

1. After mulching satisfactorily, the Department will pay 80% of the Contract Unit Price bid per square yard (meter) for the 1st landscape mulch application.
2. As directed by the engineer or a month before the final inspection (April or August), the contractor shall complete 2nd landscape mulch application (topdressing), the Department will pay 20% of the Contract Unit Price bid per square yard (meter). Such payment shall be full compensation for furnishing, installing, topdressing, and maintaining mulch as required.
3. Do not mulch marsh restoration areas.
4. Do not apply additional applications of mulch after the initial application in stream buffer restoration areas.

E. Plant Topsoil

Plant Topsoil measured for payment will be paid for as follows:

- I. Plant topsoil, eligible for payment, will be paid for at the Contract Unit Price per cubic yard. Payment is full compensation for furnishing the material, removing objectionable matter from the material, loading and unloading, stockpiling and removing from the stockpile, hauling, spreading, preparing the ground, pulverizing, mixing, remising, and for all maintenance.

Payment will be made under:

Item No. 702	Plant Name and Size	Per each
Item No. 702	Fertilizer, Spring Application	Per ton (megagram)
Item No. 708	Plant Topsoil	Per cubic yard
Item No. 702	Landscape Mulch	Per square yard (meter)
Item No. 702	Spring Application Fertilizer	Per pound (kilogram)
Item No. 702	Perimeter Stakes	Per each
Item No. 702	Bare Root Seedling Planting	Per each

702.5.01 Adjustments

General Provisions 101 through 150.

END OF SECTION

State Road and Tollway Authority (SRTA), State of Georgia

SPECIAL PROVISION

Section 708 – Plant Topsoil

708.1 General Description

This work includes furnishing and applying approved plant topsoil at the locations shown on the Plans or as directed by the Engineer and according to these Specifications.

708.1.1 Definitions

General Provisions 101 through 150.

708.1.2 Related References

A. Standard Specifications

Section 104—Scope of Work

Section 106—Control of Materials

Section 107—Legal Regulations and Responsibility to the Public

Section 893—Miscellaneous Planting Materials

B. Referenced Documents

General Provisions 101 through 150.

708.1.3 Submittals

A. Product Data: For each type of product.

1. Include recommendations for application and use.
2. Include test data substantiating that products comply with requirements.
3. Include sieve analysis for aggregate materials.
4. Material Certificates: For each type of imported soil, soil amendment and fertilizer before delivery to the site, according to the following:
 - a. Manufacturer's qualified testing agency's certified analysis of standard products.
 - b. Analysis of fertilizers, by a qualified testing agency, made according to AAPFCO methods for testing and labeling and according to AAPFCO's SUIP #25.
 - c. Analysis of nonstandard materials, by a qualified testing agency, made according to SSSA methods, where applicable.

B. Samples: For each bulk-supplied material, 1 gal. volume of each in sealed containers labeled with content, source, and date obtained. Each sample shall be typical of the lot of material to be furnished; provide an accurate representation of composition, color, and texture. Samples to be for imported material and on-site stockpiled soil. Soil samples must be approved by Landscape Architect prior to importing or spreading on-site material.

C. Informational Submittals:

1. Qualification Data: For each testing agency.
2. Preconstruction Test Reports: As specified in "Preconstruction Testing," article.
3. Field quality-control reports

708.1.4 Quality Assurance

Testing Agency Qualifications: An independent, state-operated, or university-operated laboratory; experienced in soil science, soil testing, and plant nutrition; with the experience and capability to conduct the testing indicated; and that specializes in types of tests to be performed.

708.1.5 Preconstruction Testing

- A. **Preconstruction Testing Service:** Engage a qualified testing agency to perform preconstruction soil analyses on existing on-site soil and imported soil.
 - 1. Notify Architect seven days in advance of the dates and times when laboratory samples will be taken.
- B. **Preconstruction Soil Analyses:** For each unamended soil type, perform testing on soil samples and furnish soil analysis and a written report containing soil-amendment and fertilizer recommendations by a qualified testing agency performing the testing according to "Soil-Sampling Requirements" and "Testing Requirements" articles.
 - 1. Have testing agency identify and label samples and test reports according to sample collection and labeling requirements.

708.1.6 Soil Sampling Requirements

- A. **General:** Extract soil samples according to requirements in this article.
- B. **Sample Collection and Labeling:** Have samples taken and labeled by Owner or state-certified, licensed, or registered soil scientist under the direction of the testing agency.
 - 1. **Number and Location of Samples:** Minimum of three representative soil samples from varied locations and as directed by architect for each soil to be used or amended for landscaping purposes.
 - 2. **Procedures and Depth of Samples:** According to USDA-NRCS's "Field Book for Describing and Sampling Soils."
 - 3. **Division of Samples:** Split each sample into two, equal parts. Send half to the testing agency and half to Owner for its records.
 - 4. **Labeling:** Label each sample with the date, location keyed to a site plan or other location system, visible soil condition, and sampling depth.

708.1.7 Testing Requirements

- A. **General:** Perform tests on soil samples according to requirements in this article.
- B. **Physical Testing:**
 - 1. **Soil Texture:** Soil-particle, size-distribution analysis by one of the following methods according to SSSA's "Methods of Soil Analysis - Part 1-Physical and Mineralogical Methods":
 - **Sieving Method:** Report sand-gradation percentages for very coarse, coarse, medium, fine, and very fine sand; and fragment-gradation (gravel) percentages for fine, medium, and coarse fragments; according to USDA sand and fragment sizes.
 - **Hydrometer Method:** Report percentages of sand, silt, and clay.
 - 2. **Total Porosity:** Calculate using particle density and bulk density according to SSSA's "Methods of Soil Analysis - Part 1-Physical and Mineralogical Methods."
 - 3. **Water Retention:** According to SSSA's "Methods of Soil Analysis - Part 1-Physical and Mineralogical Methods."
 - 4. **Saturated Hydraulic Conductivity:** According to SSSA's "Methods of Soil Analysis - Part 1-Physical and Mineralogical Methods"; at 85% compaction according to ASTM D 698 (Standard Proctor).

- C. **Chemical Testing:**
1. **CEC:** Analysis by sodium saturation at pH 7 according to SSSA's "Methods of Soil Analysis - Part 3- Chemical Methods."
 2. **Clay Mineralogy:** Analysis and estimated percentage of expandable clay minerals using CEC by ammonium saturation at pH 7 according to SSSA's "Methods of Soil Analysis - Part 1- Physical and Mineralogical Methods."
 3. **Metals Hazardous to Human Health:** Test for presence and quantities of RCRA metals including aluminum, arsenic, barium, copper, cadmium, chromium, cobalt, lead, lithium, and vanadium. **If RCRA metals are present, include recommendations for corrective action.**
 4. **Phytotoxicity:** Test for plant-available concentrations of phytotoxic minerals including aluminum, arsenic, barium, cadmium, chlorides, chromium, cobalt, copper, lead, lithium, mercury, nickel, selenium, silver, sodium, strontium, tin, titanium, vanadium, and zinc.
- D. **Fertility Testing:** Soil-fertility analysis according to standard laboratory protocol of SSSA NAFT NCR-13 including the following:
1. Percentage of organic matter.
 2. CEC, calcium percent of CEC, and magnesium percent of CEC.
 3. Soil reaction (acidity/alkalinity pH value).
 4. Buffered acidity or alkalinity.
 5. Nitrogen ppm.
 6. Phosphorous ppm.
 7. Potassium ppm.
 8. Manganese ppm.
 9. Manganese-availability ppm.
 10. Zinc ppm.
 11. Zinc availability ppm.
 12. Copper ppm.
 13. Sodium ppm and sodium absorption ratio.
 14. Soluble-salts ppm.
 15. Presence and quantities of problem materials including salts and metals cited in the Standard protocol. **If such problem materials are present, provide additional recommendations for corrective action.**
 16. Other deleterious materials, including their characteristics and content of each.
- E. **Organic-Matter Content:** Analysis using loss-by-ignition method according to SSSA's "Methods of Soil Analysis - Part 3- Chemical Methods."
- F. **Recommendations:** Based on the test results, state recommendations for soil treatments and soil amendments to be incorporated to produce satisfactory planting soil suitable for healthy, viable plants indicated. Include, at a minimum, recommendations for nitrogen, phosphorous, and potassium fertilization, and for micronutrients.
1. **Fertilizers and Soil Amendment Rates:** State recommendations in weight [per 1000 sq. ft. (100 sq. m) for 6-inch (150-mm)].
 2. **Soil Reaction:** State the recommended liming rates for raising pH or sulfur for lowering pH according to the buffered acidity or buffered alkalinity in weight [per 1000 sq. ft. (100 sq. m) for 6-inch (150-mm)].

708.2 Materials

A. Plant Topsoil Materials

Use plant topsoil that meets the requirements of Subsection 893.2.01.

In addition to Section 893 - Stockpiled or On-Site Soil:

1. **Excavation:** Excavate soil from designated area(s) to a depth of 6 inches (150 mm) unless otherwise specified on the plans and stockpile until amended. Provide soil test results and amend as necessary. Provide amended soil test results and samples for approval by engineer prior to spreading on-site.
2. **Unacceptable Materials:** Clean soil of concrete slurry, concrete layers or chunks, cement, plaster, building debris, oils, gasoline, diesel fuel, paint thinner, turpentine, tar, roofing compound, acid, and other extraneous materials that are harmful to plant growth.
3. **Unsuitable Materials:** Clean soil to contain a maximum of 8 percent by dry weight of stones, roots, plants, sod, clay lumps, and pockets of coarse sand. Screening Pass unamended soil through a 2-inch (50-mm) sieve to remove large materials.

B. Sources of Material

Except as modified in this Section, furnish plant topsoil material according to Section 106.

1. Plant Topsoil Obtained from the Work

The requirements of Subsection 104.06, "Right in and Use of Material Found on the Work" are in effect for plant topsoil obtained from the Work.

- a. Obtain the quantity of plant topsoil called for on the Plans.
- b. Use plant topsoil material present on the Project as long as the topsoil meets the Specifications applying to the Item.
- c. Excavate for topsoil only within the construction limits of the Project. Obtain topsoil from embankment areas, excavation areas, or borrow excavation pits.
- d. When obtaining plant topsoil from borrow excavation pits or the roadway, cross section the excavated areas a second time before beginning regular excavation.

2. Plant Topsoil Furnished by the Contractor

When insufficient material is obtainable from the Work, obtain additional topsoil offsite.

The Contract Price will include the costs necessary to locate, purchase, and deliver the required amount of acceptable material to the Work.

708.2.01 Delivery, Storage, and Handling

For the purpose of measurement, the Contractor may haul plant topsoil in any type of vehicle, provided the vehicle when loaded to capacity and traveling over public roads and streets meets the provisions of Subsection 107.14, "Load Restrictions."

When using pans or scrapers, the capacity will be the manufacturer's rated capacity.

Packaged Materials: Deliver packaged materials in original, unopened containers showing weight, certified analysis, name and address of manufacturer, and compliance with state and Federal laws if applicable.

Bulk Materials:

1. Do not dump or store bulk materials near structures, utilities, walkways and pavements, or on existing turf areas or plants.
2. Provide erosion-control measures to prevent erosion or displacement of bulk materials, discharge of soil-bearing water runoff, and airborne dust reaching adjacent properties, water conveyance systems, or walkways.
3. Do not move or handle materials when they are wet or frozen.
4. Accompany each delivery of bulk fertilizers and soil amendments with appropriate certificates.

708.3 Construction Requirements

708.3.1 Personnel

General Provisions 101 through 150.

708.3.2 Equipment

General Provisions 101 through 150.

708.3.3 Preparation

General Provisions 101 through 150.

708.3.4 Fabrication

General Provisions 101 through 150.

708.3.5 Construction

A. General Requirements

Unless otherwise specified in the Plans, uniformly spread plant topsoil to at least 2 in (50 mm) loose depth.

1. Erosion Control

Unless otherwise specified in the Plans, only use plant topsoil on slopes where the gradient is 3:1 or flatter.

To reduce loss of plant topsoil by erosion, place the soil shortly before and in conjunction with grassing operations. Place topsoil and complete grassing within specified seasonal limits.

2. Spreading Procedure

Before applying plant topsoil, scarify the designated areas 6 in to 8 in (150 mm to 200 mm) deep.

Mix the plant topsoil, lime when required, and the first application fertilizer with the underlying soil when preparing the soil for grassing. Spread and smooth the topsoil uniformly.

B. Plant Topsoil Obtained From The Work

1. Stockpiling

When obtaining topsoil from the work site, strip and stockpile the topsoil in suitable locations in advance of grading operations.

Just before grassing, remove the plant topsoil from the stockpile and spread it over the designated areas.

If grassing is started before grading operations are finished, if feasible, haul the topsoil from undisturbed areas before grading begins directly to the areas designated for the topsoil, eliminating the cost of stockpiling and removing the stockpile.

2. Surplus Material

When stockpiling more material than specified in the Contract, use the surplus material as additional plant topsoil material if directed by the Engineer.

After constructing the Item, use the surplus material left in the stockpiles to maintain the Item or to fill washes that occur within a reasonable haul distance.

Otherwise, remove or dress down the remaining material as directed by the Engineer, without additional compensation.

C. Plant Topsoil Furnished by Contractor

When locating, obtaining, and paying for plant topsoil from pits outside the right-of-way, excavate the topsoil and haul it directly to the designated areas just before the planting begins.

Notify the Engineer, according to Subsection 893.2.01, "Plant Topsoil," of the source of the material. The Engineer will inspect the topsoil. If the material is suitable, the Engineer will specify the permissible excavation depth. If the permissible excavation depth is exceeded, the material obtained from the areas will be rejected.

708.3.6 Quality Acceptance

After placing the plant topsoil, replace material lost by erosion at no expense to the Department.

708.3.7 Contractor Warranty and Maintenance

General Provisions 101 through 150.

708.4 Measurement

Accepted plant topsoil for this Item is measured by the cubic yard (meter) of material delivered in vehicles to the designated areas for plant topsoil. Only vehicles loaded to full capacity are measured for payment. No payment will be made for material delivered in partially filled vehicles.

Plant topsoil is not measured for payment when it is used for an Item that includes the cost of the plant topsoil in the price bid per Unit for the Item.

708.4.01 Limits

General Provisions 101 through 150.

708.5 Payment

Plant topsoil, eligible for payment, will be paid for at the Contract Unit Price per cubic yard (meter). Payment is full compensation for furnishing the material, removing objectionable matter from the material, loading and unloading, stockpiling and removing from the stockpile, hauling, spreading, preparing the ground, pulverizing, mixing, remixing, and for all maintenance.

Payment will be made under:

Item No. 708.	Plant topsoil	Per cubic yard (meter)
---------------	---------------	------------------------

708.5.01 Adjustments

General Provisions 101 through 150.

END OF SECTION

State Road and Tollway Authority (SRTA), State of Georgia

SPECIAL PROVISION

Section 754 – Outdoor Furniture

PART 1 - GENERAL

1.01 SUMMARY

- A. This work includes furnishing, fabricating, and installing outdoor furnishings as shown on the plans, and shall include, but is not limited to, the following components:
 - 1. Bench
 - 2. Leaning Rail
 - 3. Bike Rack
 - 4. Blast Resistant Trash Receptacle

1.02 RELATED REFERENCES

- A. Drawings and general provisions of the Contract, including General Conditions and Standard Specification sections apply to this Section.

1.03 PRE-INSTALLATION MEETING

- A. Preinstallation Conference: Conduct conference at Project Site.

1.04 SUBMITTALS

- A. **Product Data:** Contractor shall submit manufacturer's technical data for each type of product. This information shall include installation instructions, material descriptions, dimensions of individual components and profiles, sizes, colors, finishes, anchoring method, and field-assembly requirements.
- B. **Samples:** Contractor shall submit actual material color and finish samples. Size of samples to be not less than 6-inches long for linear components and 4-inches square for sheet components.
- C. **Project Schedule:** For outdoor furnishings. Use same designations indicated on Plans.
- D. **Material Certificates:** For outdoor furnishings, signed by manufacturers.
- E. **Maintenance Data:** For outdoor furnishings, to include in maintenance manuals.

1.05 QUALITY ASSURANCE

- A. Manufacturer shall have a minimum of 10 years' experience in designing, fabrication, and installing the specified outdoor furnishings.
- B. Installation shall be performed by a qualified installer.

1.06 WARRANTY

- A. Manufacturer warrants that outdoor furnishing unit shall be free from defect in parts and manufacture for a period of one year.
- B. Manufacturer shall maintain inventory of replacement parts for minimum of ten years after delivery of outdoor furnishing.

PART 2 - PRODUCTS**2.01 MATERIALS**

- A. Refer to Construction Documents for Material and Manufacturers.

2.02 FABRICATION

- A. Metal components: Form to required shapes and sizes with true, consistent curves, lines, and angles. Separate metals from dissimilar materials to prevent electrolytic action.
- B. Welded Connections: Weld connections continuously. Weld solid members with full-length, full-penetration welds and hollow members with full-circumference welds. At exposed connections, finish surfaces smooth and blended so no roughness or unevenness shows after finishing and welded surface matches contours of adjoining surfaces.
- C. Pipes and Tubes: Form simple and compound curves by bending members in jigs to produce uniform curvature for each repetitive configuration required; maintain cylindrical cross section of member throughout entire bend without buckling, twisting, cracking, or otherwise deforming exposed surfaces of handrail and railing components.
- D. Steel and Iron Components: Galvanized, galvanized and color coated, or color coated. Bare metal steel or iron components are not permitted.
- E. Exposed Surfaces: Polished, sanded, or otherwise finished; smooth all surfaces, free from burrs, barbs, splinters, and sharpness; all edges and ends rolled, rounded, or capped.
- F. Factory Assembly: Assemble components in the factory to the greatest extent possible to minimize field assembly. Clearly mark units for assembly in the field.

2.03 FINISHES - GENERAL

- A. Compliance: Comply with NAAMM's "Metal Finishes Manual for Architectural and Metal Products" for recommendations for applying and designating finishes.
- B. Appearance of Finished Work: Variations in appearance of abutting or adjacent pieces are acceptable if they are within one-half of the range of approved Samples. Noticeable variations in

the same piece are not acceptable. Variations in appearance of other components are acceptable if they are within the range of approved Samples and are assembled or installed to minimize contrast.

2.04 DELIVERY, STORAGE, AND HANDLING

- A. Acceptance at site: Coordinate delivery of work to Project site under this section for immediate installation. Outdoor Furnishings shall be delivered fully assembled.
- B. Store Materials in clean, dry area in accordance with manufacturer's instructions. Keep materials in original, unopened containers and packaging until installation. Do not store in direct contact with the sun or rain.
- C. Handling materials and equipment: Handle outdoor furnishings in careful manner in order not to damage or mar surfaces finishes.

PART 3 - EXECUTION

3.01 EXAMINATION

- A. Examine areas and conditions, with Installer present, for compliance with requirements for correct and level finished grade, mounting surfaces, installation tolerances, and other conditions affecting performance.
- B. Proceed with installation only after unsatisfactory conditions have been corrected.

3.02 INSTALLATION - GENERAL

- A. Comply with manufacturer's written installation instructions, unless more stringent requirements are indicated. Complete field assembly of outdoor furnishings, where required.
- B. Unless otherwise indicated, install outdoor furnishings after landscaping and paving have been completed.
- C. Install outdoor furnishings level, plumb, true and securely anchored at locations indicated on the Plans.

3.03 CLEANING

- A. After completing outdoor furnishing installation, inspect components. Remove spots, dirt, and debris. Repair damaged finishes to match original finish or replace component.

3.04 MEASUREMENT

- A. The accepted outdoor furniture quantities are measured in per each fixture in place in the completed work.

3.05 PAYMENT

- A. Outdoor furniture is paid for at the unit price bid per each unit complete and in place as specified. The payment is full compensation for all excavation, furnishing and installation of each unit, including foundation / footing, anchoring units, disposal of excavated material, and the cost of furnishing all tools, safety devices, labor, equipment and all other necessary items to complete the work.

END OF SECTION

State Road and Tollway Authority (SRTA), State of Georgia

SPECIAL PROVISION

Section 009 – Miscellaneous Construction Advertising / Map Case Display

PART 1 - GENERAL

1.01 SUMMARY

- A. This work includes furnishing, fabricating, and installing advertising / map case display as shown on the plans and details.

1.02 RELATED REFERENCES

- A. Drawings and general provisions of the Contract, including General Conditions and Standard Specification sections apply to this Section.

1.03 PRE-INSTALLATION MEETING

- A. Preinstallation Conference: Conduct conference at Project Site.

1.04 SUBMITTALS

- A. **Product Data:** Contractor shall submit manufacturer's technical data for each type of product. This information shall include installation instructions, material descriptions, dimensions of individual components and profiles, sizes, colors, finishes, anchoring method, and field-assembly requirements.
- B. **Shop Drawings:** Submit structural engineering design documents bearing the seal of a structural engineer in the state of Georgia for Display/Advertising Case concrete footing and anchoring details.
- C. **Samples:** Contractor shall submit actual material color and finish samples. Size of samples to be not less than 6-inches long for linear components and 4-inches square for sheet components.
- D. **Project Schedule:** For installation of advertising / map case display.
- E. **Material Certificates:** For advertising / map case display, signed by manufacturer.
- F. **Maintenance Data:** For advertising / map case display, to include in maintenance manuals.

1.05 QUALITY ASSURANCE

- A. Manufacturer shall have a minimum of 10 years' experience in designing, fabrication, and installing the specified outdoor furnishings.
- B. Installation shall be performed by a qualified installer.

1.06 WARRANTY

- A. Manufacturer warrants that unit shall be free from defect in parts and manufacture for a period of one year.
- B. Manufacturer shall maintain inventory of replacement parts for minimum of ten years after delivery of unit.

PART 2 - PRODUCTS**2.01 MATERIALS**

- A. Refer to Construction Documents for Material and Manufacturers.

2.02 FABRICATION

- A. Metal components: Form to required shapes and sizes with true, consistent curves, lines, and angles. Separate metals from dissimilar materials to prevent electrolytic action.
- B. Welded Connections: Weld connections continuously. Weld solid members with full-length, full-penetration welds and hollow members with full-circumference welds. At exposed connections, finish surfaces smooth and blended so no roughness or unevenness shows after finishing and welded surface matches contours of adjoining surfaces.
- C. Pipes and Tubes: Form simple and compound curves by bending members in jigs to produce uniform curvature for each repetitive configuration required; maintain cylindrical cross section of member throughout entire bend without buckling, twisting, cracking, or otherwise deforming exposed surfaces of handrail and railing components.
- D. Steel and Iron Components: Galvanized, galvanized and color coated, or color coated. Bare metal steel or iron components are not permitted.
- E. Exposed Surfaces: Polished, sanded, or otherwise finished; smooth all surfaces, free from burrs, barbs, splinters, and sharpness; all edges and ends rolled, rounded, or capped.
- F. Factory Assembly: Assemble components in the factory to the greatest extent possible to minimize field assembly. Clearly mark units for assembly in the field.

2.03 FINISHES - GENERAL

- A. Compliance: Comply with NAAMM's "Metal Finishes Manual for Architectural and Metal Products" for recommendations for applying and designating finishes.

- B. **Appearance of Finished Work:** Variations in appearance of abutting or adjacent pieces are acceptable if they are within one-half of the range of approved Samples. Noticeable variations in the same piece are not acceptable. Variations in appearance of other components are acceptable if they are within the range of approved Samples and are assembled or installed to minimize contrast..

2.04 DELIVERY, STORAGE, AND HANDLING

- A. **Acceptance at site:** Coordinate delivery of work to Project site under this section for immediate installation.
- B. **Store Materials** in clean, dry area in accordance with manufacturer's instructions. Keep materials in original, unopened containers and packaging until installation. Do not store in direct contact with the sun or rain.
- C. **Handling materials and equipment:** Handle in careful manner in order not to damage or mar surfaces finishes.

PART 3 - EXECUTION

3.01 EXAMINATION

- A. **Examine areas and conditions,** with Installer present, for compliance with requirements for correct and level finished grade, mounting surfaces, installation tolerances, and other conditions affecting performance.
- B. **Proceed with installation only after** unsatisfactory conditions have been corrected.

3.02 INSTALLATION - GENERAL

- A. **Comply with manufacturer's written installation instructions,** unless more stringent requirements are indicated. Complete field assembly of advertising / map case display where required.
- B. **Unless otherwise indicated,** install advertising / map case display after landscaping and paving have been completed.
- C. **Install advertising / map case display level, plumb, true and securely anchored** at locations indicated on the Plans.

3.03 CLEANING

- A. **After completing installation,** inspect components. Remove spots, dirt, and debris. Repair damaged finishes to match original finish or replace component.

3.04 MEASUREMENT

- A. **The accepted advertising / map case display quantities** are measured in per lump sum in place in the completed work.

3.05 PAYMENT

- A. Advertising / map case display is paid for per lump sum complete and in place as specified. The payment is full compensation for all excavation, furnishing and installation of each unit, including preparation of footing/anchoring unit, disposal of excavated material, and the cost of furnishing all tools, safety devices, labor, equipment and all other necessary items to complete the work.

END OF SECTION

State Road and Tollway Authority (SRTA), State of Georgia

SPECIAL PROVISION

Section 999 – Miscellaneous Construction

Section 999.1 General Description

Pay Item No. 999-9000 is intended for Miscellaneous Construction which may or may not be required on the project as directed/requested by the Engineer. Use of this item will be only as specifically authorized by the SRTA or its designee.

Every effort will be made to negotiate an acceptable price with the Contractor for miscellaneous construction. If SRTA or its designee is unable to negotiate an agreeable price with the Contractor, SRTA reserves the right to negotiate both price and warranties with specialty contractors for this purpose. The Contractor will then be required to include the work authorized, utilizing the authorized specialty subcontractor. A maximum allowance of 5% may be included for overhead purposes of the prime contractor above the negotiated specialty contractor agreement.

Section 999.2 Payment

For payment purposes, negotiated prices will be converted to a percentage of Item No. 999-9000. Payment for this item will be only for amounts authorized by the Engineer. Final Payment may or may not equal 100% of the Lump Sum Price included in the Contract.

Payment will be made under:

Item No. 999-9000 Miscellaneous Construction.....per Lump Sum

THIS PAGE IS INTENTIONALLY LEFT BLANK



State Road and Tollway Authority
245 Peachtree Center Ave, NE, Suite 2200
Atlanta GA, 30303-1224
Phone: (404) 893-6100
Fax: (404) 893-6160
www.srta.ga.gov